



ELECTRICAL CIRCUIT DIAGRAMS

SUPER TURBO-X 48 MARK II
SUPER TURBO-X 510 MARK II
SUPER TURBO-X 612 MARK II

SERIAL NUMBER :

MANUAL NO. DD676001012A

MANUAL NO.

ELEMENTARY DIAGRAM LIST

SET No. : DD 676 001 012

Drawn By : M.Okajima

DATE : May. 23. 2005

Checked By : M.Okajima

FOR : Japan, MANI-C. Others

Approved By : M.Itho

No.	ITEM	SPECIFICATION
1	MACHINE TYPE	ST-X48/510/612Mk II
2	MACHINE No.	676/677/678
3	CNC TYPE	MAZATROL L32B
4	LASER TYPE	MATSUSHITA TYPE8 :1.5/1.8/2.5/4 KW
5	PLC ROM No.	DS 676 LT01 **
6		
7		

Remarks
DD 676 001 011 EXCEPT "O" MARK
Option

No.	DRAWING No.	TITLE	
1	676 001 1001 1,0	INSTALL EXPLAIN (JAPAN, EXPORT)	設置説明 (日本, 輸出)
2	676 001 1101 0,0	BLOCK DIAGRAM	ブロック図
3	676 001 1201 1,0	M CODE LIST	Mコードリスト
4			
5	676 001 3001 1,0	MACHINE COMPORNENTS LAYOUT (1)	機器配置 (1)
6	676 001 3002 2,0	MACHINE COMPORNENTS LAYOUT (2)	機器配置 (2)
7	676 001 3003 3,0	MACHINE COMPORNENTS LAYOUT (3)	機器配置 (3)
8	676 001 3004 1,0	MACHINE COMPORNENTS LAYOUT (4)	機器配置 (4)
9	676 001 3005 0,0	MACHINE COMPORNENTS LAYOUT (5)	機器配置 (5)
10	676 001 3006 0,0	MACHINE COMPORNENTS LAYOUT (6)	機器配置 (6)
11	676 001 3007 0,0	MACHINE COMPORNENTS LAYOUT (7)	機器配置 (7)
12	676 001 3008 1,0	MACHINE COMPORNENTS LAYOUT (8)	機器配置 (8)
13	676 001 3009 0,0	MACHINE COMPORNENTS LAYOUT (9)	機器配置 (9)
14			
15	676 001 5001 2,0	CABINET LAYOUT	制御盤配置
16	676 001 5002 3,0	CABINET INLET LAYOUT	制御盤配置
17	676 001 5005 5,0	CB PANEL LAYOUT	CBパネル配置
18	676 001 5006 2,0	NC, TB PANEL LAYOUT	NC, TBパネル配置
19	676 001 5007 3,0	TERMINAL BLOCK LAYOUT	端子台配置
20	676 001 5008 2,0	CONNECTOR BRAKET LAYOUT	コネクタブラケット配置
21	676 001 5010 2,0	TU (A11), STU (A12) LAYOUT	TU (A11), STU (A12) 配置
22	676 001 5011 0,0	TU (A11) CONNECTOR TABLE (1)	TU (A11) コネクター一覧 (1)
23	676 001 5012 1,0	TU (A11) CONNECTOR TABLE (2)	TU (A11) コネクター一覧 (2)
24	676 001 5013 1,0	TU (A11) CONNECTOR TABLE (3)	TU (A11) コネクター一覧 (3)
25	676 001 5014 0,0	STU (A12) CONNECTOR TABLE	STU (A12) コネクター一覧
26	676 001 5020 1,0	SSR BOARD (A13) LAYOUT	SSRボード (A13) 配置
27	676 001 5025 0,0	OPU-100 (A14) LAYOUT (OPTION)	OPU-100 (A14) 配置 (オプション)
28			
29			
30	676 001 5050 0,0	NC (A1) LAYOUT	NC (A1) 配置
31	676 001 5051 0,0	NC (A1) CONNECTOR TABLE (1)	NC (A1) コネクター一覧 (1)
32	676 001 5052 0,0	NC (A1) CONNECTOR TABLE (2)	NC (A1) コネクター一覧 (2)
33	676 001 5053 0,0	NC (A1) CONNECTOR TABLE (3)	NC (A1) コネクター一覧 (3)
34	676 001 5060 1,0	SERVO AMP LAYOUT	サーボアンプ配置
35	676 001 5061 0,0	SERVO AMP CONNECTOR TABLE	サーボアンプコネクター一覧
36	676 001 5070 0,0	NC OPERATING PANEL LAYOUT (1)	NC操作パネル配置 (1)
37	676 001 5071 0,0	NC OPERATING PANEL LAYOUT (2)	NC操作パネル配置 (2)
38	676 001 5072 0,0	NC OPERATING PANEL LAYOUT (3)	NC操作パネル配置 (3)
39	676 001 5073 0,0	NC OPERATING PANEL CONNECTOR TABLE	NC操作パネルコネクター一覧
40	676 001 5075 2,0	OPERATING PANEL LAYOUT	操作パネル配置
41			
42			
43			
44			
45			

ELEMENTARY DIAGRAM LIST

SET No. : DD 676 001 012

No.	DRAWING No.	TITLE	
46	676 001 4001 1,0	MAIN POWER (1)	主動力回路 (1)
47	676 001 4003 1,0	MAIN POWER (2)	主動力回路 (2)
48	676 001 4005 0,0	CONTROL AC100V	AC100V制御電源
49	676 001 4007 0,0	DC POWER SUPPLY	DC制御電源
50	676 001 4010 0,0	AC100V CIRCUIT	AC100V回路
51	676 001 4012 0,0	WORK LIGHT	ワークライト
52	676 001 4013 0,0	SIGNAL LIGHT	シグナルライト
53	676 001 4014 0,0	CHIP CONVEYER	チップコンベア
54	676 001 4014 0,1	CHIP CONVEYER	チップコンベア
55	676 001 4015 1,0	LUBRICATOR	潤滑ユニット
56	676 001 4016 3,0	EXHAUST UNIT	排気装置
57	676 001 4017 1,0	EXHAUST UNIT (2)	排気装置 (2)
58	676 001 4019 0,0	AUX. DRY AIR	光路エアパージ
59	676 001 4020 1,0	NC POWER UNIT	NC電源ユニット
60	676 001 4021 0,0	NC OPERATING PANEL INTERFACE	NC操作パネルインターフェース
61	676 001 4022 0,0	NC OPERATING PANEL CONNECTION (1)	NC操作パネル接続 (1)
62	676 001 4023 0,0	NC OPERATING PANEL CONNECTION (2)	NC操作パネル接続 (2)
63	676 001 4025 0,0	NC OPERATING SWITCH (1)	NC操作スイッチ (1)
64	676 001 4026 0,0	NC OPERATING SWITCH (2)	NC操作スイッチ (2)
65	676 001 4027 1,0	NC HANDLE INTERFACE	NCハンドルインターフェース
66	676 001 4030 0,0	PROGRAM I/O INTERFACE	プログラムI/Oインターフェース
67	676 001 4031 1,0	DNC INTERFACE (OPTION)	DNCインターフェース (オプション)
68	676 001 4040 1,0	SERVO AMP POWER CONNECTION	サーボアンプ動力接続
69	676 001 4045 0,0	X AXIS SERVO AMP	X軸サーボアンプ
70	676 001 4046 0,0	Y AXIS SERVO AMP	Y軸サーボアンプ
71	676 001 4047 0,0	Z AXIS SERVO AMP	Z軸サーボアンプ
72	676 001 4050 1,0	X AXIS SERVO MOTOR	X軸サーボモータ
73	676 001 4051 1,0	Y AXIS SERVO MOTOR	Y軸サーボモータ
74	676 001 4052 1,0	Z AXIS SERVO MOTOR	Z軸サーボモータ
75	676 001 4060 1,0	POWER ON	電源オン
76	676 001 4061 1,0	INTERLOCK	インターロック
77	676 001 4065 2,0	AXIS LS	軸リミットスイッチ
78	676 001 4070 1,0	EMERGENCY STOP (1)	非常停止 (1)
79	676 001 4071 1,0	EMERGENCY STOP (2)	非常停止 (2)
80	676 001 4080 4,0	LASER UNIT (1)	レーザ発信器 (1)
81	676 001 4081 1,0	LASER UNIT (2)	レーザ発信器 (2)
82	676 001 4082 1,0	LASER UNIT (3)	レーザ発信器 (3)
83	676 001 4083 2,0	LASER UNIT (4)	レーザ発信器 (4)
84	676 001 4090 1,0	CHILLER UNIT	チラーユニット
85	676 001 4100 1,0	ASSIST GAS	アシストガス
86	676 001 4101 0,0	ASSIST GAS REGULATOR	電空レギュレータ
87	676 001 4102 1,0	ASSIST GAS HIGH PS (OPTION)	高圧アシストガス (オプション)
88	676 001 4103 1,0	4th ASSIST GAS (OPTION)	第4アシストガス (オプション)
89	676 001 4105 0,0	HIGH PRESSURE ASSIST GAS REGULATOR (1) (OPTION)	高圧電空レギュレータ (1) (オプション)
90	676 001 4106 0,0	HIGH PRESSURE ASSIST GAS REGULATOR (2) (OPTION)	高圧電空レギュレータ (2) (オプション)
91	676 001 4110 1,0	GAP SENSOR SWITCH	ならいスイッチ
92	676 001 4111 1,0	POTENTIOMETER GAP SENSOR	接触式ならい
93	676 001 4115 0,0	NON CONTACT GAP SENSOR (OPTION)	非接触式ならい (オプション)
94	676 001 4116 2,0	NON CONTACT GAP SENSOR MAZAK TYPE (OPTION)	非接触ならい マザクタイプ (オプション)
95	676 001 4120 0,0	NON CONTACT GAP SENSOR WEIDMULLER TYPE (NOT USED)	非接触ならい ワイデミュラータイプ (使用禁止)
96			
97			
98			
99			
100			

ELEMENTARY DIAGRAM LIST

SET No. : DD 676 001 012

No.	DRAWING No.	TITLE	
101	676 001 4130 1,0	WORK CLAMP	ワーククランプ
102	676 001 4132 3,0	WORK CLAMP SENSOR (OPTION)	ワーククランプ センサー (オプション)
103	676 001 4133 2,0	WORK ON SENSOR (OPTION)	ワークオンセンサー (オプション)
104	676 001 4135 0,0	WORK LIFTER	ワークリフター
105	676 001 4140 1,0	PROGRAMMABLE FOCUS (OPTION)	自動レンス可動トーチ (オプション)
106	676 001 4145 0,0	PIERCING ADAPTER (1) (OPTION)	ピアッシングアダプター (1) (オプション)
107	676 001 4146 1,0	PIERCING ADAPTER (2) (OPTION)	ピアッシングアダプター (2) (オプション)
108	676 001 4150 0,0	SIDE BLOW (OPTION)	サイドブロー (オプション)
109	676 001 4160 1,0	LIGHT BARRIER	ライトバリアー
110	676 001 4170 1,0	SIDE COVER	サイドカバー
111	676 001 4175 0,0	FRONT COVER	フロントカバー
112	676 001 4180 1,0	SLIDE COVER (1) (OPTION)	スライドカバー (1) (オプション)
113	676 001 4181 0,0	SLIDE COVER (2) (OPTION)	スライドカバー (2) (オプション)
114			
115	676 001 4185 2,0	SETUP	セットアップ
116	676 001 4186 0,0	CE COVER INTERLOCK (NOT USED)	CEカバーインターロック (使用禁止)
117	676 001 4190 0,0	FIXED COVER (OPTION)	
118	676 001 4195 0,0	PALLET COVER (OPTION)	
119			
120	676 001 4210 0,0	AUTO/ALARM POWER OFF (OPTION)	自動電源遮断 (オプション)
121	676 001 4220 1,0	LEAK DETECTION BREAKER (OPTION)	漏電遮断器 (オプション)
122	676 001 4250 0,0	TOUCH SENSOR (1) (NOT USED)	タッチセンサー (1) (使用禁止)
123	676 001 4251 0,0	TOUCH SENSOR (2) (NOT USED)	タッチセンサー (2) (使用禁止)
124	676 001 4290 1,0	SPARE M CODE (OPTION)	スペアモード (オプション)
125	676 001 4291 1,0	EXTERNAL SIGNAL (OPTION)	外部信号 (オプション)
126			
127	676 001 4300 1,0	PALLET CLAMP (OPTION)	パレットクランプ (オプション)
128	676 001 4310 0,0	PALLET INTERFACE (1) (OPTION)	パレットチェンジインターフェース (1) (オプション)
129	676 001 4311 0,0	PALLET INTERFACE (2) (OPTION)	パレットチェンジインターフェース (2) (オプション)
130	676 001 4312 1,0	PALLET INTERFACE (3) (OPTION)	パレットチェンジインターフェース (3) (オプション)
131	676 001 4313 2,0	PALLET INTERFACE (4) (OPTION)	パレットチェンジインターフェース (4) (オプション)
132	676 001 4314 3,0	PALLET INTERFACE (5) (OPTION)	パレットチェンジインターフェース (5) (オプション)
133	676 001 4315 2,0	PALLET INTERFACE (6) (OPTION)	パレットチェンジインターフェース (6) (オプション)
134			
135	676 001 4701 3,0	PC INPUT SPARE	PC入力スペア
136	676 001 4702 4,0	PC OUTPUT SPARE	PC出力スペア
137	676 001 4703 0,0	TU SPARE	TUスペア
138	676 001 4705 4,0	XT31, 51, 71 SPARE	XT31, 51, 71スペア
139	676 001 4707 0,0	OPERATING PANEL SPARE	操作パネルスペア
140			
141			
142			
143			
144			
145			
146			
147			
148			
149			
150			
151			
152			
153			
154			
155			

ELEMENTARY DIAGRAM LIST

SET No. : DD 676 001 012

No.	DRAWING No.	TITLE	
156	676 001 3011 0,0	CONTROL CABINET (1)	制御盤 (1)
157	676 001 3012 3,0	CONTROL CABINET (2)	制御盤 (2)
158	676 001 3013 3,0	CONTROL CABINET (3)	制御盤 (3)
159	676 001 3015 0,0	CONTROL CABINET (4)	制御盤 (4)
160	676 001 3016 1,0	AUX. TRANS BOX	輸出トランスBOX
161	676 001 3031 4,0	XT31 (1)	XT31 (1)
162	676 001 3032 2,0	XT31 (2)	XT31 (2)
163	676 001 3033 2,0	XT31 (3)	XT31 (3)
164	676 001 3034 1,0	XT31 (4)	XT31 (4)
165	676 001 3051 1,0	XT51	XT51
166	676 001 3071 4,0	XT71 (1)	XT71 (1)
167	676 001 3072 3,0	XT71 (2)	XT71 (2)
168	676 001 3073 1,0	XT71 (3)	XT71 (3)
169	676 001 3074 0,0	XT71 (4)	XT71 (4)
170			
171	676 001 5101 1,0	POWER CIRCUIT CONNECTION (JAPAN, EXPORT)	動力回路接続 (日本, 輸出向)
172	676 001 5110 1,0	CABINET CABLE CONNECTION (1)	制御盤内ケーブル接続 (1)
173	676 001 5111 0,0	CABINET CABLE CONNECTION (2)	制御盤内ケーブル接続 (2)
174	676 001 5112 1,0	CABINET CABLE CONNECTION (3)	制御盤内ケーブル接続 (3)
175	676 001 5115 1,0	NOIZE MEASURES	ノイズ対策
176			
177			
178			
179	676 001 3601 0,0	PALLET CHANGER (OPTION) COMPORNENTS LAYOUT(1)	パレットチェンジャー (オプション) 機器配置(1)
180	676 001 3602 0,0	PALLET CHANGER (OPTION) COMPORNENTS LAYOUT(2)	パレットチェンジャー (オプション) 機器配置(2)
181	676 001 5601 2,0	PALLET CHANGER (OPTION) BOX LAYOUT	パレットチェンジャー (オプション) 制御BOX配置
182	676 001 5602 1,0	PALLET CHANGER (OPTION) CONNECTOR BRAKET LAYOUT	パレットチェンジャー (オプション) コネクタブラケット配置
183	676 001 4601 1,0	PALLET CHANGER (OPTION) POWER CIRCUIT	パレットチェンジャー (オプション) 動力回路
184	676 001 4610 0,0	PALLET CHANGER (OPTION) SERVO PACK	パレットチェンジャー (オプション) サーボパック
185	676 001 4611 1,0	PALLET CHANGER (OPTION) UP/DOWN MOTOR 1	パレットチェンジャー (オプション) 上昇/下降モータ 1
186	676 001 4612 1,0	PALLET CHANGER (OPTION) UP/DOWN MOTOR 2	パレットチェンジャー (オプション) 上昇/下降モータ 2
187	676 001 4613 1,0	PALLET CHANGER (OPTION) UP/DOWN MOTOR 3	パレットチェンジャー (オプション) 上昇/下降モータ 3
188	676 001 4614 1,0	PALLET CHANGER (OPTION) UP/DOWN MOTOR 4	パレットチェンジャー (オプション) 上昇/下降モータ 4
189	676 001 4615 0,0	PALLET CHANGER (OPTION) FWD/REV MOTOR	パレットチェンジャー (オプション) 走行モータ
190	676 001 4620 1,0	PALLET CHANGER (OPTION) SERVO READY & ALARM	パレットチェンジャー (オプション) サーボレディ&アラーム
191	676 001 4631 2,0	PALLET CHANGER (OPTION) SERVO PACK 1	パレットチェンジャー (オプション) サーボパック 1
192	676 001 4632 2,0	PALLET CHANGER (OPTION) SERVO PACK 2	パレットチェンジャー (オプション) サーボパック 2
193	676 001 4633 2,0	PALLET CHANGER (OPTION) SERVO PACK 3	パレットチェンジャー (オプション) サーボパック 3
194	676 001 4634 2,0	PALLET CHANGER (OPTION) SERVO PACK 4	パレットチェンジャー (オプション) サーボパック 4
195	676 001 4635 2,0	PALLET CHANGER (OPTION) SERVO PACK 5	パレットチェンジャー (オプション) サーボパック 5
196	676 001 4640 2,0	PALLET CHANGER (OPTION) OPERATING PANEL (1)	パレットチェンジャー (オプション) 操作パネル (1)
197	676 001 4641 2,0	PALLET CHANGER (OPTION) OPERATING PANEL (2)	パレットチェンジャー (オプション) 操作パネル (2)
198	676 001 4650 1,0	PALLET CHANGER (OPTION) WORK CLAMP	パレットチェンジャー (オプション) ワーククランプ
199	676 001 4651 2,0	PALLET CHANGER (OPTION) PALLET CLAMP	パレットチェンジャー (オプション) パレットクランプ
200	676 001 4652 2,0	PALLET CHANGER (OPTION) PALLET SENSOR	パレットチェンジャー (オプション) パレットセンサー
201	676 001 4660 2,0	PALLET CHANGER (OPTION) LIGHT BARRIER	パレットチェンジャー (オプション) ライトバリアー
202	676 001 4690 1,0	PALLET CHANGER (OPTION) LOADER INTERFACE	パレットチェンジャー (オプション) ロータインターフェース
203	676 001 4695 0,0	PALLET CHANGER (OPTION) SPARE	パレットチェンジャー (オプション) スペア
204	676 001 3611 1,0	PALLET CHANGER (OPTION) PALLET BOX (1)	パレットチェンジャー (オプション) パレットBOX (1)
205	676 001 3612 2,0	PALLET CHANGER (OPTION) PALLET BOX (2)	パレットチェンジャー (オプション) パレットBOX (2)
206	676 001 3613 0,0	PALLET CHANGER (OPTION) PALLET BOX (3)	パレットチェンジャー (オプション) パレットBOX (3)
207	676 001 3615 1,0	PALLET CHANGER (OPTION) XT63	パレットチェンジャー (オプション) XT63
208	676 001 3617 1,0	PALLET CHANGER (OPTION) OPERATING PANEL LAYOUT	パレットチェンジャー (オプション) 操作パネル配置
209	676 001 5611 0,0	PALLET CHANGER (OPTION) PALLET BOX CONNECTION	パレットチェンジャー (オプション) パレットBOX接続
210			

ELEMENTARY DIAGRAM LIST

SET No. : DD 676 001 012

No.	DRAWING No.	TITLE	
266	676 001 1301 5,0	PARTS LIST DIRECTORY (JAPAN)	パーツリストディレクトリー (日本)
267	676 001 1302 5,0	PARTS LIST DIRECTORY (EXPORT)	パーツリストディレクトリー (輸出)
268			
269	676 001 1310 3,0	CABINET (1)	制御盤 (1)
270	676 001 1311 4,0	CABINET (2)	制御盤 (2)
271	676 001 1312 3,0	CABINET (3)	制御盤 (3)
272	676 001 1313 7,0	CABINET (4)	制御盤 (4)
273	676 001 1314 1,0	CABINET (5)	制御盤 (5)
274	676 001 1320 7,0	OUTSIDE CABLE (1) (48Mk II)	機間ケーブル (1) (48Mk II)
275	676 001 1321 1,0	OUTSIDE CABLE (2) (48Mk II)	機間ケーブル (2) (48Mk II)
276	676 001 1323 8,0	OUTSIDE CABLE (1) (510Mk II)	機間ケーブル (1) (510Mk II)
277	676 001 1324 1,0	OUTSIDE CABLE (2) (510Mk II)	機間ケーブル (2) (510Mk II)
278	676 001 1326 5,0	OUTSIDE CABLE (1) (612Mk II)	機間ケーブル (1) (612Mk II)
279	676 001 1327 1,0	OUTSIDE CABLE (2) (612Mk II)	機間ケーブル (2) (612Mk II)
280	676 001 1330 2,0	TERMINAL BOX	中継箱
281	676 001 1340 2,0	AUX. TRANSFORMER (1) (EXPORT)	輸出トランス (1) (輸出)
282	676 001 1341 3,0	AUX. TRANSFORMER (2) (EXPORT)	輸出トランス (2) (輸出)
283			
284	676 001 1350 3,0	HIGH PRESSURE GAS (OPTION)	高圧アシストガス (オプション)
285	676 001 1352 1,0	EXHAUST UNIT (OPTION)	排気装置 (オプション)
286	676 001 1354 3,0	GAP SENSOR (OPTION)	非接触ならい (オプション)
287	676 001 1356 1,0	RETRACE (OPTION)	リトレース (オプション)
288	676 001 1358 1,0	DNC INTERFACE (OPTION)	DNCインターフェース (オプション)
289	676 001 1360 1,0	LOADER SENSOR (OPTION)	ロータセンサー (オプション)
290	676 001 1362 0,0	AUTO & ALARM POWER OFF (OPTION)	自動電源遮断 (オプション)
291	676 001 1364 1,0	PROGRAMMABLE FOCUS (OPTION)	自動レンズ可動トーチ (オプション)
292	676 001 1366 2,0	PIERCING ADAPTER (OPTION)	ピアッシングアダプタ (オプション)
293	676 001 1368 2,0	SIDE BLOW (OPTION)	サイドブロー (オプション)
294	676 001 1370 0,0	3 STEPS SIGNAL LIGHT (OPTION)	3段階シグナルライト (オプション)
295	676 001 1372 1,0	LEAK DETECTION BREAKER (OPTION)	漏電遮断器 (オプション)
296			
297	676 001 1380 6,0	ENCLOSURE COVER (1) (OPTION)	保護カバー (1) (オプション)
298	676 001 1381 4,0	ENCLOSURE COVER (2) (OPTION)	保護カバー (2) (オプション)
299	676 001 1390 4,0	PALLET CHANGER (1) (OPTION)	パレットチェンジャ (1) (オプション)
300	676 001 1391 5,0	PALLET CHANGER (2) (OPTION)	パレットチェンジャ (2) (オプション)
301	676 001 1392 4,0	PALLET CHANGER (3) (OPTION)	パレットチェンジャ (3) (オプション)
302	676 001 1393 0,0	PALLET CHANGER (4) (OPTION)	パレットチェンジャ (4) (オプション)
303			
304			
305			
306			
307			
308			
309			
310			
311			
312			
313			
314			
315			
316			
317			
318			
319			
320			

01 A B C D E F G H I J K L M N O P

△₁

02
03
04
05
06
07
08
09
10
11
12
13
14
15
16
17
18
19
20
21
22
23
24
25
26
27
28
29
30

MAIN VOLTAGE 電源電圧 [V]		200	210	220	230	240	380	400	415	440	460	480
FREQUENCY 周波数 [Hz]		50/60										
TOTAL POWER REQUIREMENTS 総電源容量 [KVA]	1.5/1.8KW	35.1										
	2.5KW	58.9										
	4.0KW	82.7										
TOTAL RATED CONSUMPTION 総消費電力 [KW]	1.5/1.8KW	26.9										
	2.5KW	45										
	4.0KW	63.3										
TOTAL RATED CURRENT 総定格電流 [A]	1.5/1.8KW	101	97	92	88	85	53	51	49	46	44	42
	2.5KW	170	162	155	148	142	90	85	82	77	74	71
	4.0KW	239	228	217	208	199	126	120	115	109	104	100
MAX. INPUT FUSE ヒューズ最大値 [A]	1.5/1.8KW	125										
	2.5KW	200										
	4.0KW	250										
RECOMMENDED CROSS SECTION 電源線の太さ [mm ²] (): PROTECTIVE EARTH アース線	1.5/1.8KW	50mm ² (30mm ²)					14mm ² (14mm ²)					
	2.5KW	100mm ² (50mm ²)					38mm ² (22mm ²)					
	4.0KW	200mm ² (100mm ²)					60mm ² (30mm ²)					
MIN. RATED FAULT CURRENT OF CIRCUIT BREAKER WITH EARTH LEAKAGE PROTECTION 漏電ブレーカ定格感度電流の最小値 [mA]		500										

STD	48	510	612	
CE	1.5Kw	2.5Kw	4Kw	

△		 YAMAZAKI MAZAK CORPORATION	APR'D BY 99/11/30 T. Inoue	CHK'D BY 99/11/30 M Okajima	DRWN BY 99/11/30 M Okajima	TITLE INSTALL EXPLAIN (JAPAN, EXPORT) DRWN NO. 676 001 10011, 0
△						
△						
△	Edition Jul.05.'01 M. Okajima					

This product is subject to all the applicable Japanese Foreign Exchange and Foreign Trade Law.
 本品は『外国為替及び外国貿易法』に該当しますので外国に輸出する場合には同法に基づく許可を必要とします。

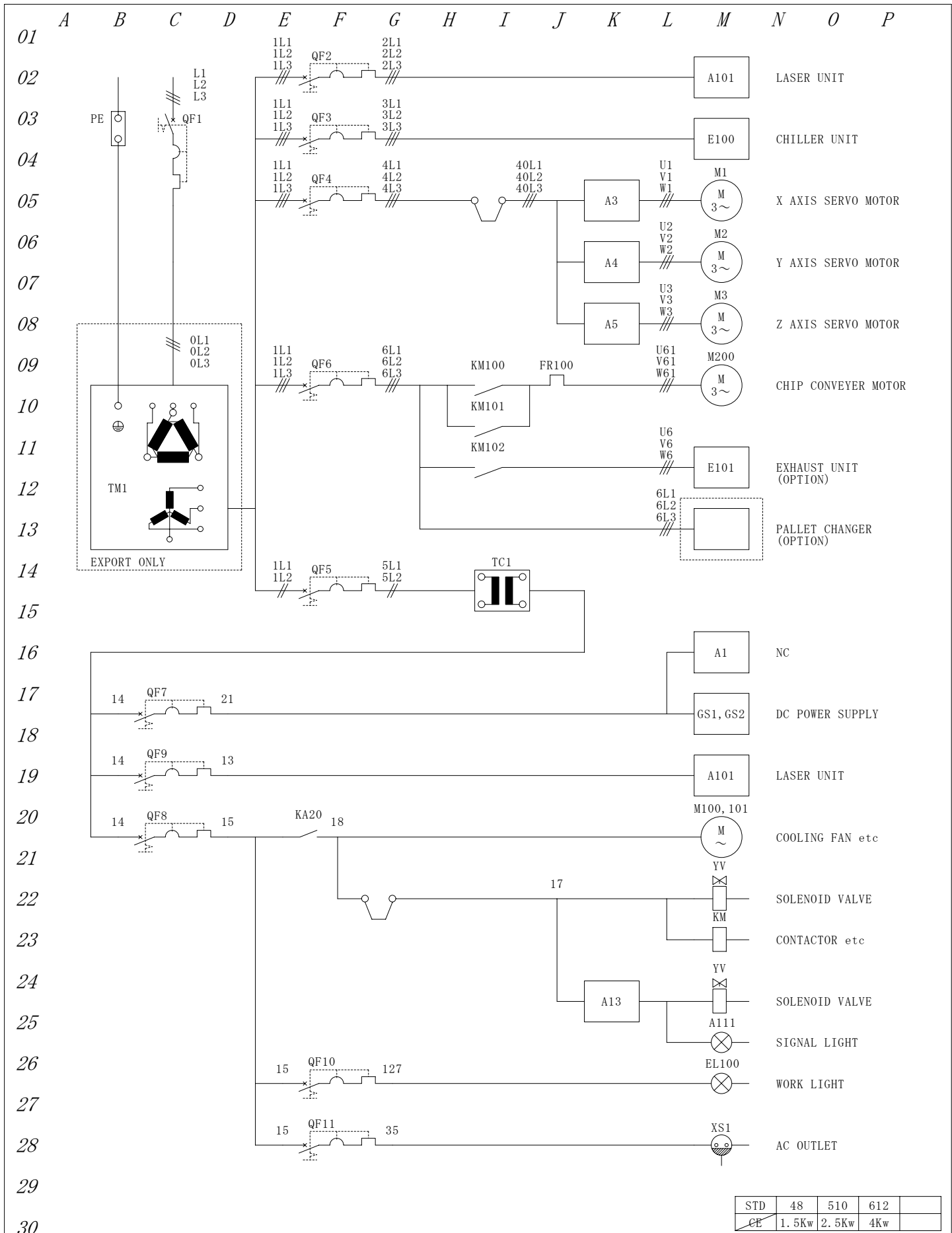

△		 YAMAZAKI MAZAK CORPORATION	APR'D BY	CHK'D BY	DRWN BY	TITLE
△			00/08/01	00/08/01	00/08/01	BLOCK DIAGRAM
△			T. Inoue	M Okajima	M Okajima	
△						DRWN NO. 676 001 11010, 0
△						

This product is subject to all the applicable Japanese Foreign Exchange and Foreign Trade Law.
 本品は『外国為替及び外国貿易法』に該当しますので外国に輸出する場合には同法に基づく許可を必要とします。

01 A B C D E F G H I J K L M N O P
M CODE LIST

02	COMMENT	REMARK	COMMENT	REMARK	COMMENT	REMARK
03	M00 PROGRAM STOP		M50 ASSIST GAS O2 HIGH		M100	
	M01 OPTIONAL STOP		M51 ASSIST GAS O2 LOW		M101	
04	M02 PROGRAM END		M52 ASSIST GAS AIR HIGH		M102	
	M03		M53 ASSIST GAS AIR LOW		M103	
05	M04		M54 ASSIST GAS 3rd HIGH		M104	
	M05		M55 ASSIST GAS 3rd LOW		M105	
06	M06		M56 ASSIST GAS O2 SELECT		M106	
	M07		M57 ASSIST GAS AIR SELECT		M107	
07	M08		M58 ASSIST GAS 3rd SELECT		M108	
	M09 ASSIST GAS STOP		M59		M109	
08	M10		M60 SIDE AIR BLOW ON	OPTION	M110	
	M11		M61 SIDE AIR BLOW OFF	OPTION	M111	
09	M12 NIBBLING MODE ON	PRESS	M62		M112	
	M13 NIBBLING MODE OFF	PRESS	M63 ASSIST GAS 3rd MODE	OPTION	M113	
10	M14		M64 ASSIST GAS 4th MODE	OPTION	M114	
	M15		M65 OIL MIST OFF	OPTION	M115	
11	M16		M66 OIL MIST ON	OPTION	M116	
	M17		M67		M117	
12	M18		M68		M118	
	M19		M69		M119	
13	M20 LASER SHUTTER OPEN		M70 PALLET CHANGE	OPTION	M120	
	M21 LASER SHUTTER CLOSE		M71		M121	
14	M22 LASER DISCHARGE ON		M72		M122	
	M23 LASER DISCHARGE OFF		M73		M123	
15	M24		M74		M124	
	M25		M75		M125	
16	M26		M76		M126	
	M27		M77 SPARE M CODE	OPTION	M127	
17	M28		M78 SPARE M CODE	OPTION	M128	
	M29		M79 SPARE M CODE	OPTION	M129	
18	M30 PROGRAM RESET & REWIND		M80		M130 LENS UNCLAMP	OPTION
	M31 AUTO GAP CONTROL OFF		M81 LOADER LOAD	OPTION	M131 LENS CLAMP	OPTION
19	M32 AUTO GAP CONTROL ON		M82 LOADER UNLOAD	OPTION	M132 LENS BYPASS ON	OPTION
	M33 Z AXIS POSITIONING		M83 LOADER UNLOAD & LOAD	OPTION	M133 LENS BYPASS OFF	OPTION
20	M34 STYLUS DOWN		M84 LOADER SETTING	OPTION	M134	
	M35 M32+M22	PRESS	M85 LOADER SPARE M CODE	OPTION	M135	
21	M36 M31+M23+M09	PRESS	M86 LOADER SPARE M CODE	OPTION	M136	
	M37 M32, M35->M33	PRESS	M87		M137	
22	M38 NEGLECT M32, M33, M35	PRESS	M88 SLIDE COVER OPEN	OPTION	M138	
	M39 M37, M38 CANCEL	PRESS	M89 SLIDE COVER CLOSE	OPTION	M139	
23	M40 NEGLECT M31	PRESS	M90		M140	
	M41 M40 CANCEL	PRESS	M91		M141	
24	M42 M43 CANCEL	PRESS	M92		M142	
	M43 NEGLECT Z AXIS UP/DOWN	PRESS	M93		M143	
25	M44 APPROACH XY->Z	PRESS	M94		M144	
	M45 APPROACH XYZ	PRESS	M95		M145	
26	M46		M96		M146	
	M47		M97		M147	
27	M48		M98 SUB. PROGRAM CALL		M148	
	M49		M99 SUB. PROGRAM RETURN		M149	

△

STD	48	510	612	
CE	1.5Kw	2.5Kw	4Kw	

△		 YAMAZAKI MAZAK CORPORATION	APR'D BY	CHK'D BY	DRWN BY	TITLE
△			99/11/30	99/11/30	99/11/30	M CODE LIST
△			T. Inoue	M Okajima	M Okajima	
△	Edition Jan.18.'02 M.Okajima					DRWN NO. 676 001 12011,0

This product is subject to all the applicable Japanese Foreign Exchange and Foreign Trade Law.
 本品は『外国為替及び外国貿易法』に該当しますので外国に輸出する場合には同法に基づく許可を必要とします。

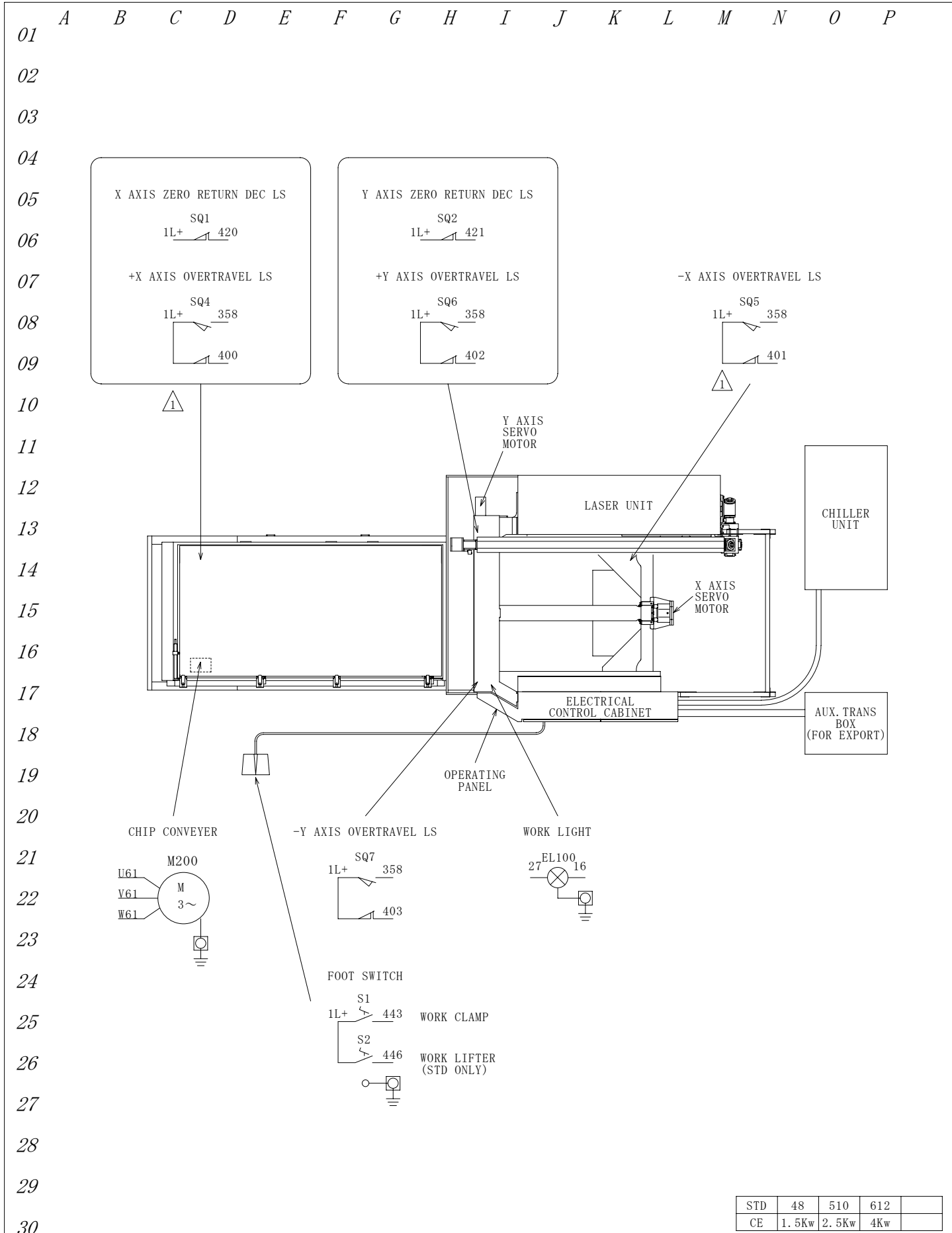

STD	48	510	612	
CE	1.5Kw	2.5Kw	4Kw	

△		 YAMAZAKI MAZAK CORPORATION	APR'D BY	CHK'D BY	DRWN BY	TITLE
△			99/11/30	99/11/30	99/11/30	MACHINE COMPONENTS LAYOUT (1)
△			T. Inoue	M Okajima	M Okajima	DRWN NO. 676 001 30011, 0
△	Edition Nov.01.'00 M.Okajima					

This product is subject to all the applicable Japanese Foreign Exchange and Foreign Trade Law.
 本品は『外国為替及び外国貿易法』に該当しますので外国に輸出する場合には同法に基づく許可を必要とします。

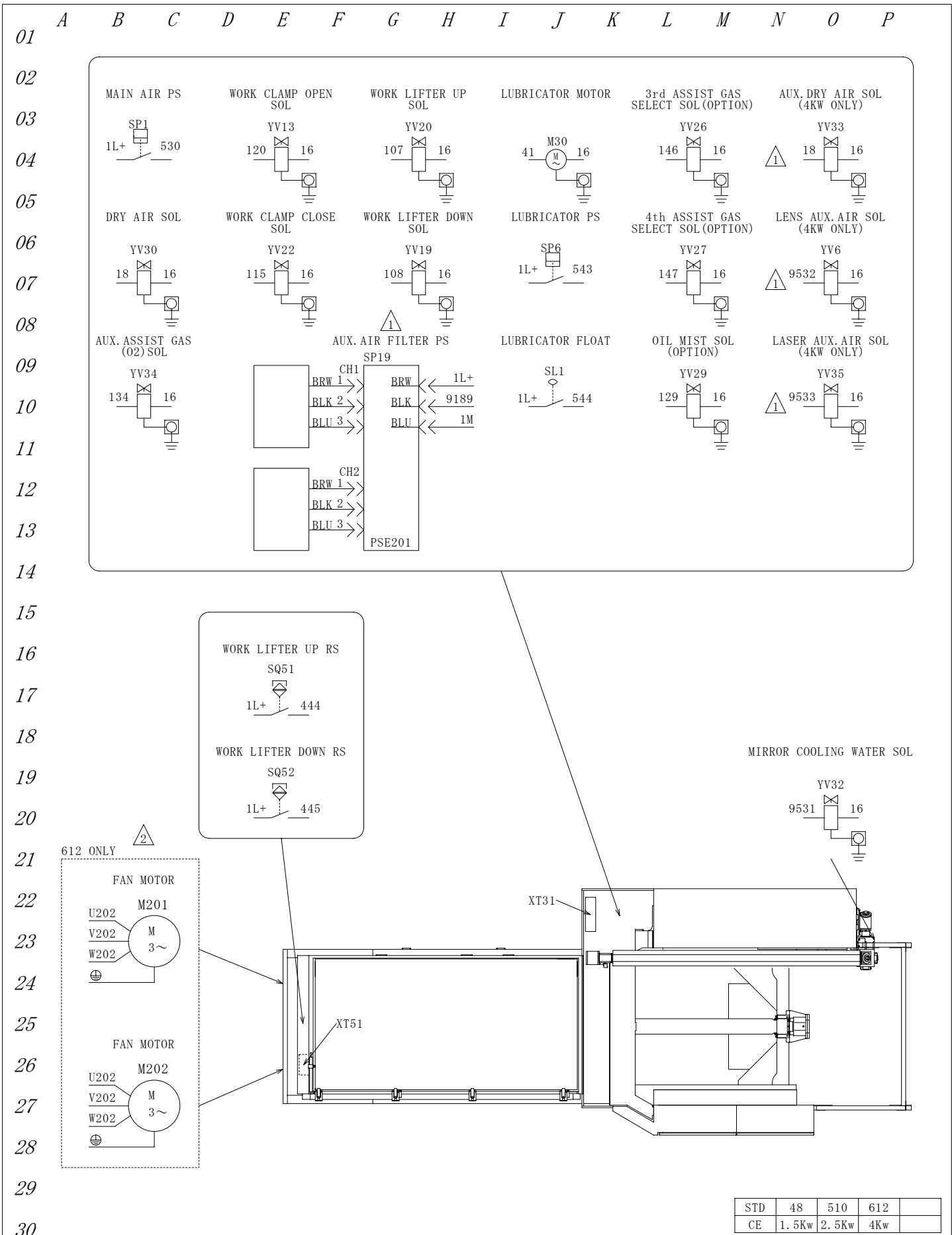

STD	48	510	612	
CE	1.5Kw	2.5Kw	4Kw	

△		 YAMAZAKI MAZAK CORPORATION	APR'D BY	CHK'D BY	DRWN BY	TITLE
△			99/11/30	99/11/30	99/11/30	MACHINE COMPONENTS LAYOUT (2)
△			T. Inoue	M Okajima	M Okajima	DRWN NO.
△			676 001 30022, 0			
△	Edition Mar. 28. '05 M. Okajima					
△	Edition Oct. 10. '03 M. Okajima					

This product is subject to all the applicable Japanese Foreign Exchange and Foreign Trade Law.
 本品は『外国為替及び外国貿易法』に該当しますので外国に輸出する場合には同法に基づく許可を必要とします。

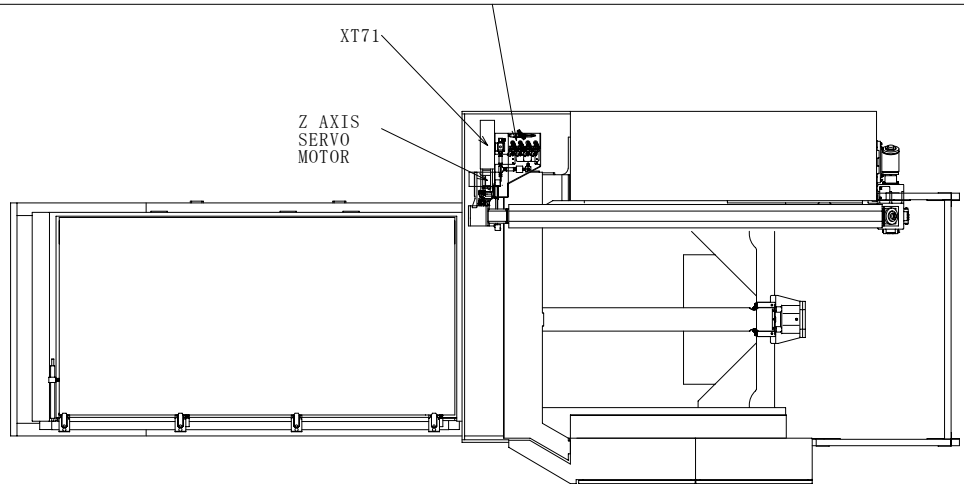
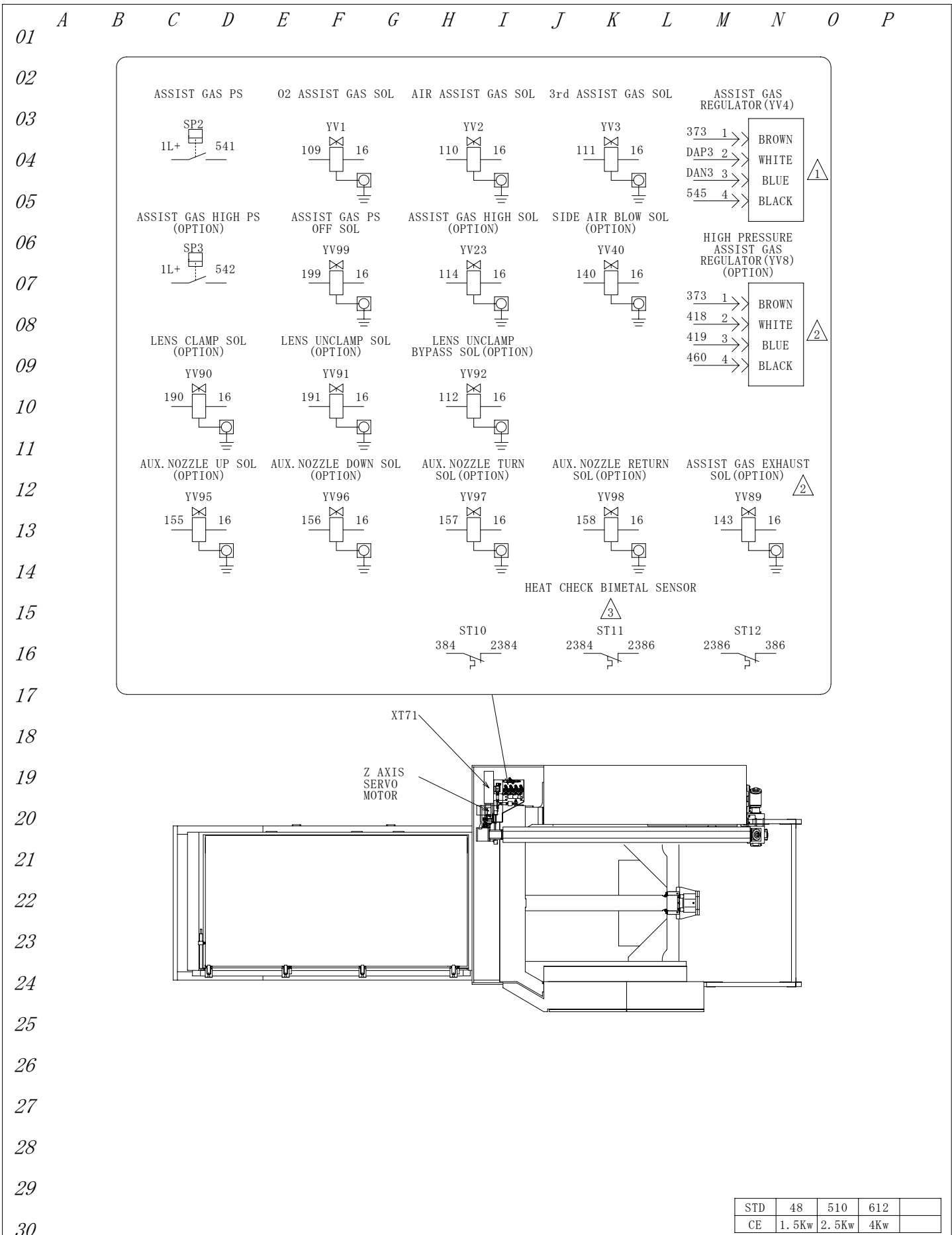

STD	48	510	612	
CE	1.5Kw	2.5Kw	4Kw	

△		 YAMAZAKI MAZAK CORPORATION	APR'D BY	CHK'D BY	DRWN BY	TITLE
△			99/11/30	99/11/30	99/11/30	MACHINE COMPONENTS LAYOUT (3)
△	Edition Jan. 26. '04 M. Okajima		T. Inoue	M. Okajima	M. Okajima	DRWN NO. 676 001 30033, 0
△	Edition Dec. 19. '01 M. Okajima					
△	Edition May. 11. '01 M. Okajima					

This product is subject to all the applicable Japanese Foreign Exchange and Foreign Trade Law. 本品は『外国為替及び外国貿易法』に該当しますので外国に輸出する場合には同法に基づく許可を必要とします。

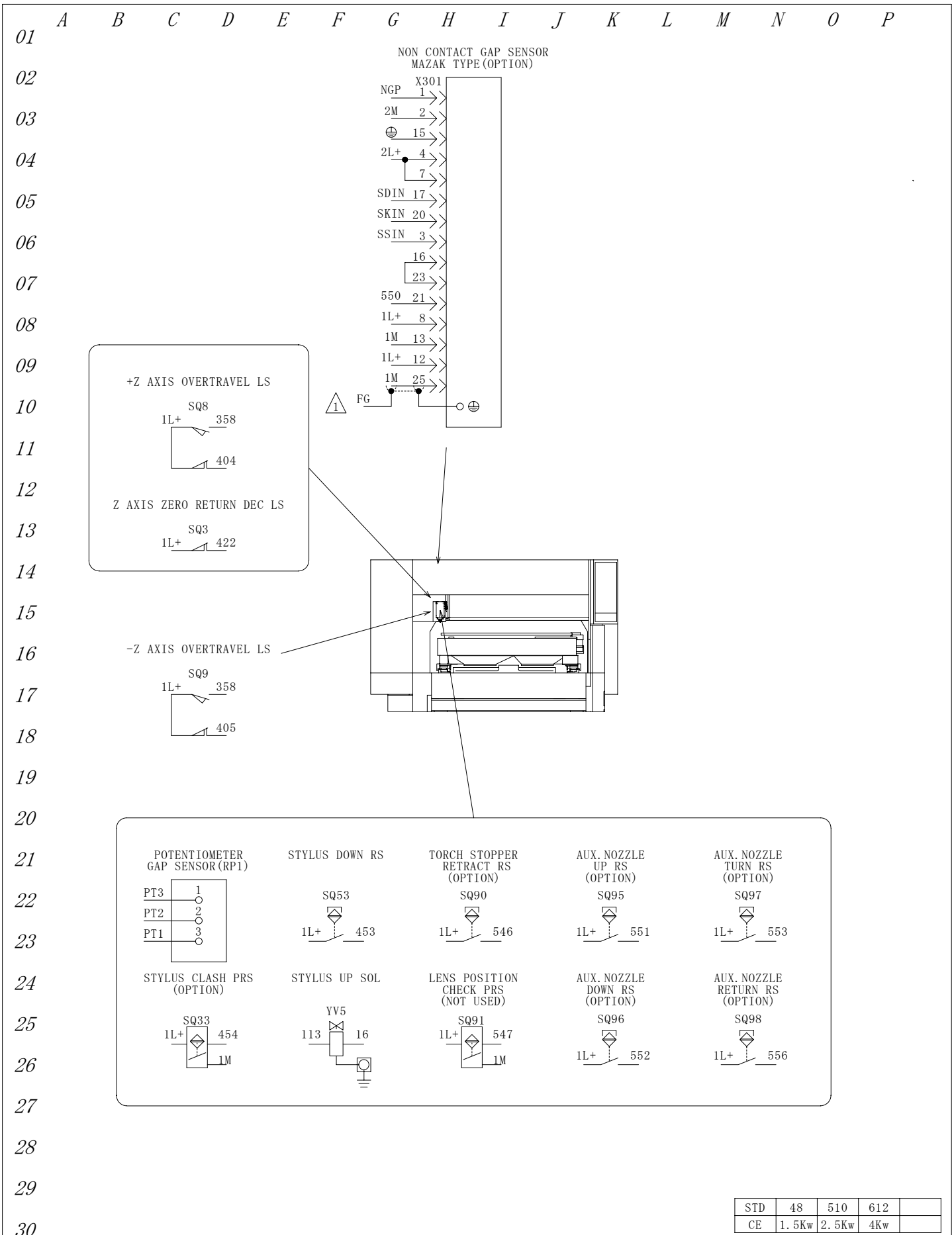

STD	48	510	612	
CE	1.5Kw	2.5Kw	4Kw	

△		 YAMAZAKI MAZAK CORPORATION	APR' D BY	CHK' D BY	DRWN BY	TITLE
△			99/11/30	99/11/30	99/11/30	MACHINE COMPONENTS LAYOUT (4)
△			T. Inoue	M Okajima	M Okajima	DRWN NO. 676 001 30041, 0
△	Edition Jul.26.'01 M.Okajima					

This product is subject to all the applicable Japanese Foreign Exchange and Foreign Trade Law.
 本品は『外国為替及び外国貿易法』に該当しますので外国に輸出する場合には同法に基づく許可を必要とします。

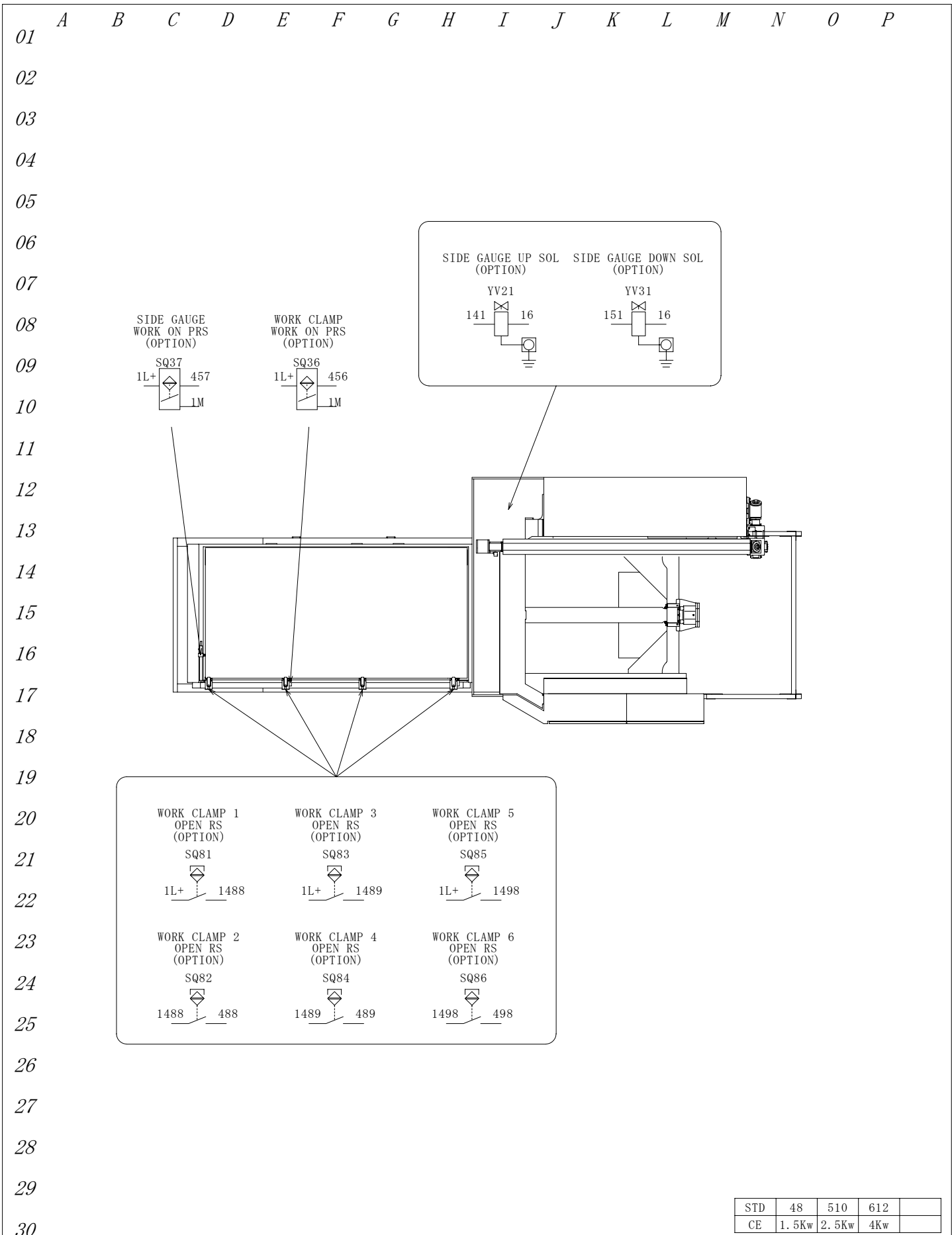

STD	48	510	612	
CE	1.5Kw	2.5Kw	4Kw	

△		 YAMAZAKI MAZAK CORPORATION	APR'D BY	CHK'D BY	DRWN BY	TITLE
△			99/11/30	99/11/30	99/11/30	MACHINE COMPONENTS LAYOUT (5)
△			T. Inoue	M Okajima	M Okajima	DRWN NO.
△						676 001 30050, 0
△						

This product is subject to all the applicable Japanese Foreign Exchange and Foreign Trade Law.
 本品は『外国為替及び外国貿易法』に該当しますので外国に輸出する場合には同法に基づく許可を必要とします。

01
02
03
04
05
06
07
08
09
10
11
12
13
14
15
16
17
18
19
20
21
22
23
24
25
26
27
28
29
30

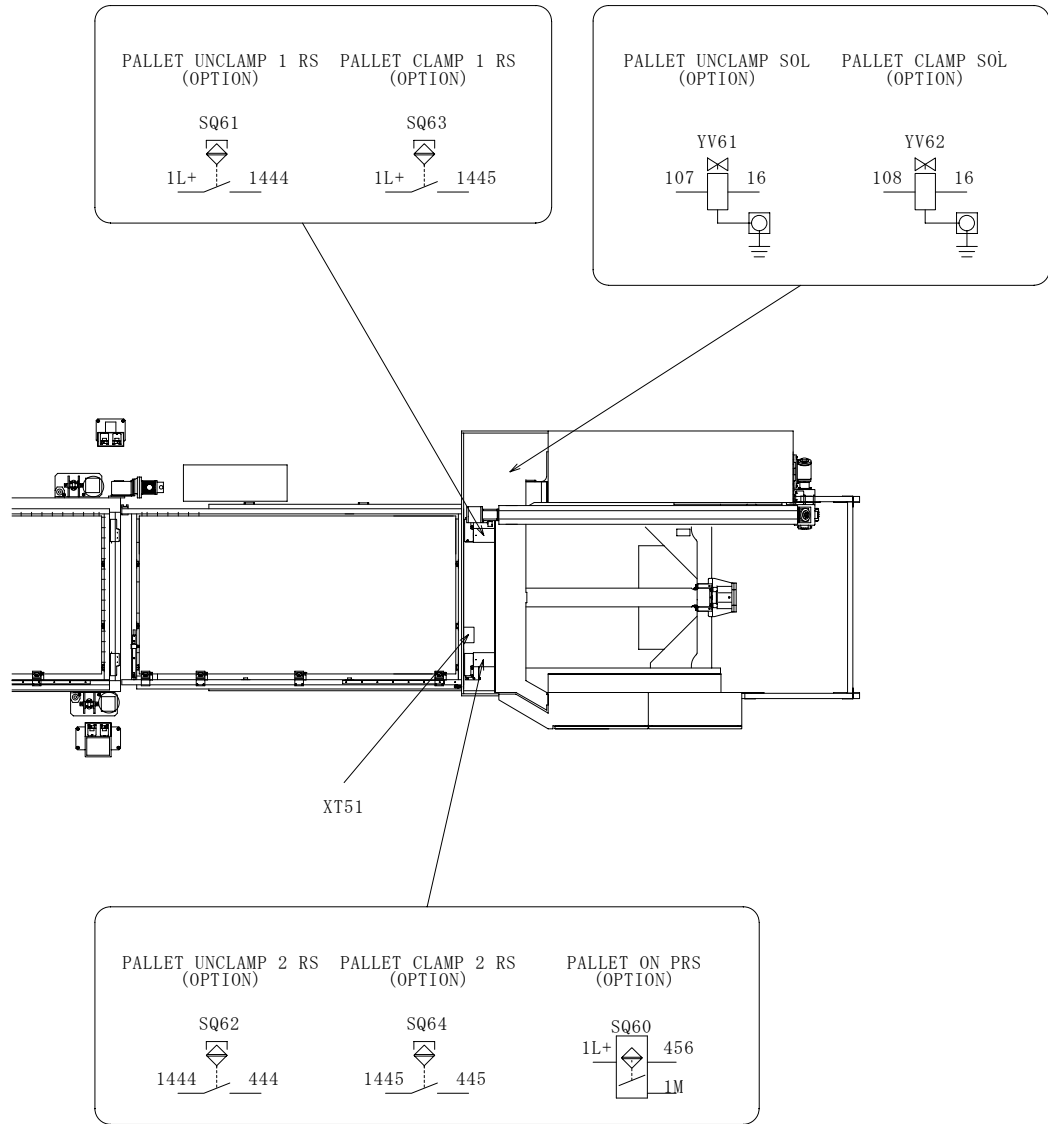

STD	48	510	612	
CE	1.5Kw	2.5Kw	4Kw	

△		 YAMAZAKI MAZAK CORPORATION	APR'D BY	CHK'D BY	DRWN BY	TITLE
△			99/11/30	99/11/30	99/11/30	MACHINE COMPONENTS LAYOUT (6)
△			T. Inoue	M Okajima	M Okajima	DRWN NO. 676 001 30060, 0
△						
△						

This product is subject to all the applicable Japanese Foreign Exchange and Foreign Trade Law.
 本品は『外国為替及び外国貿易法』に該当しますので外国に輸出する場合には同法に基づく許可を必要とします。

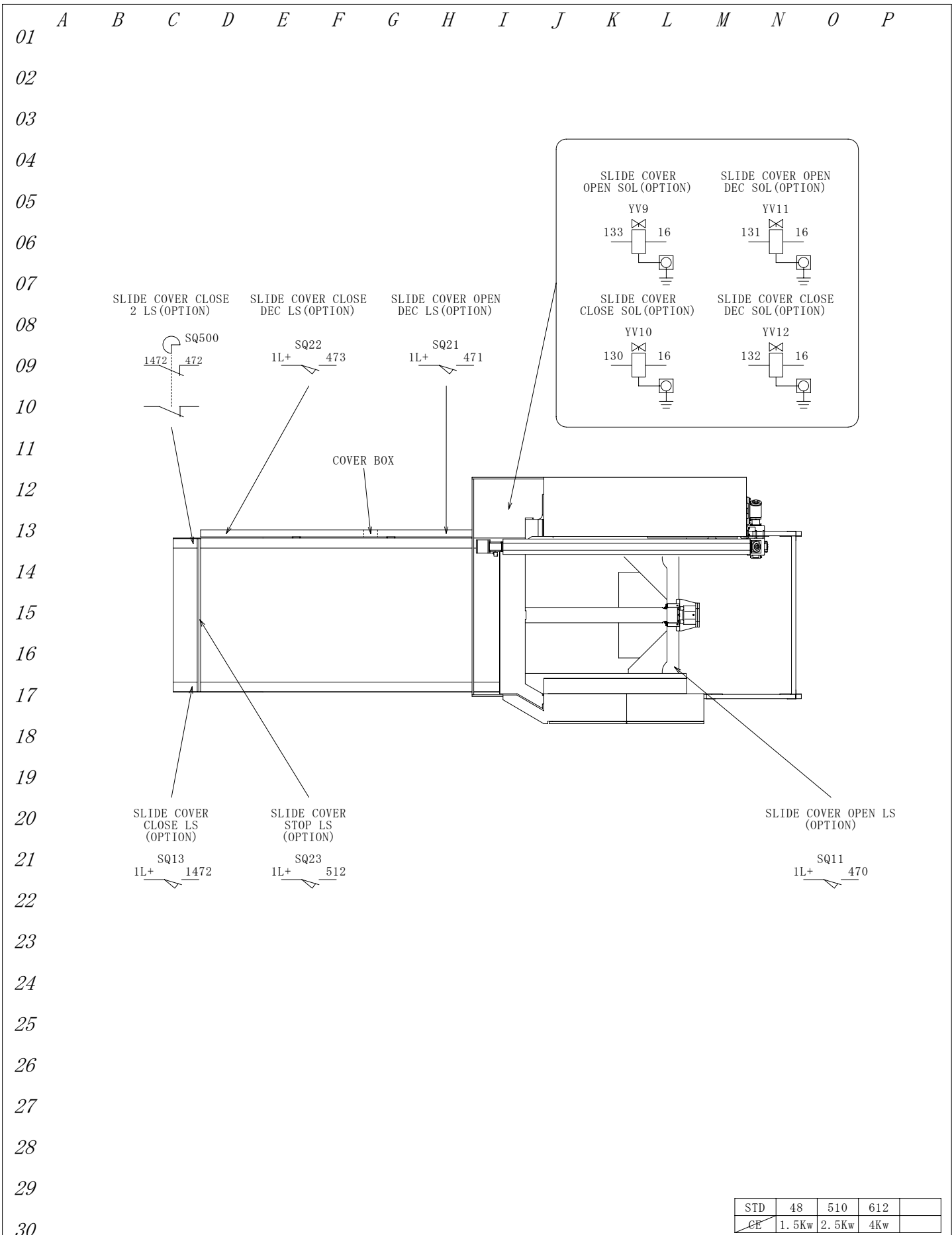

STD	48	510	612	
CE	1.5Kw	2.5Kw	4Kw	

△		 YAMAZAKI MAZAK CORPORATION	APR'D BY	CHK'D BY	DRWN BY	TITLE
△			99/11/30	99/11/30	99/11/30	MACHINE COMPONENTS LAYOUT (7)
△			T. Inoue	M Okajima	M Okajima	DRWN NO. 676 001 30070, 0
△						
△						

This product is subject to all the applicable Japanese Foreign Exchange and Foreign Trade Law.
 本品は『外国為替及び外国貿易法』に該当しますので外国に輸出する場合には同法に基づく許可を必要とします。

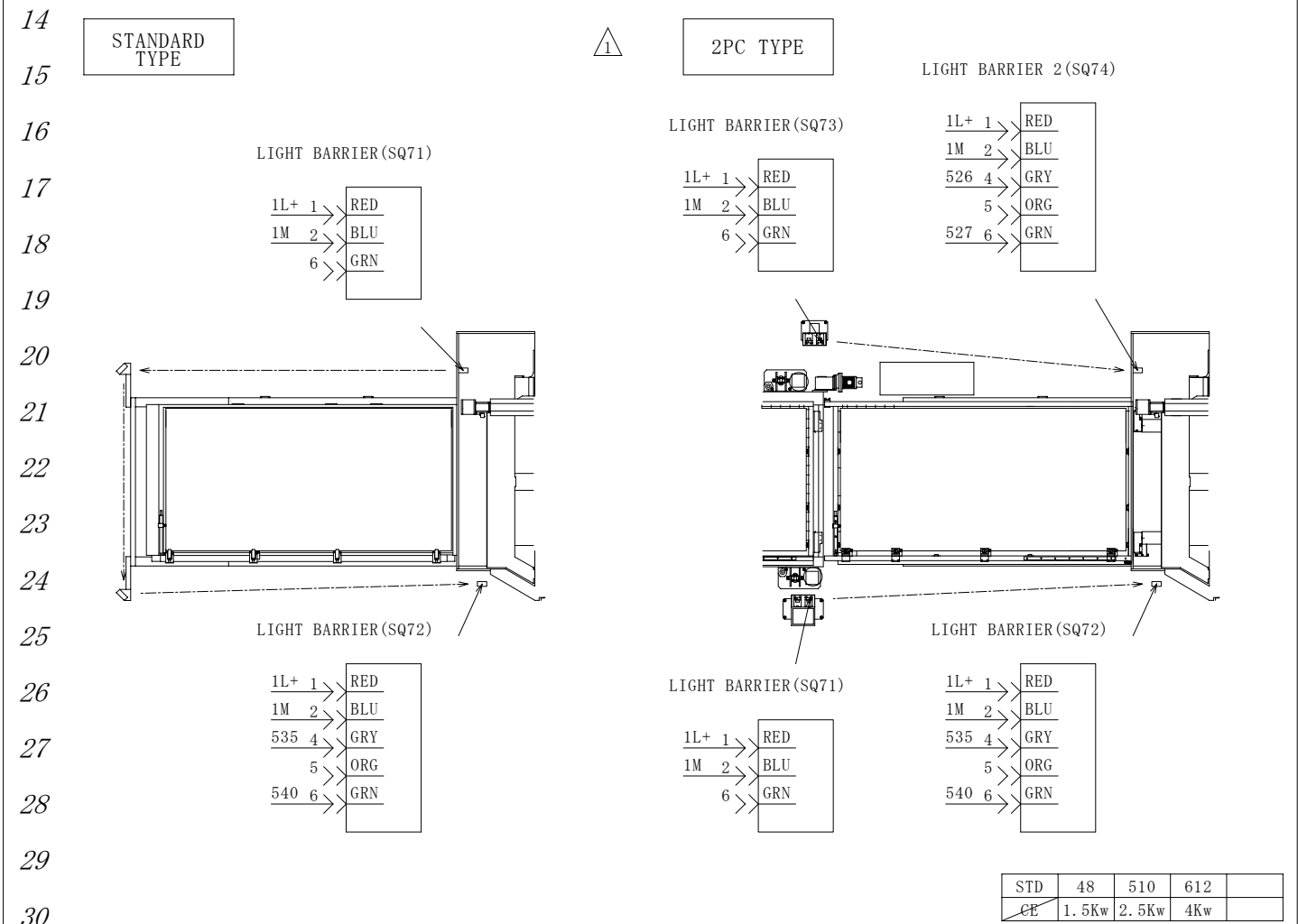
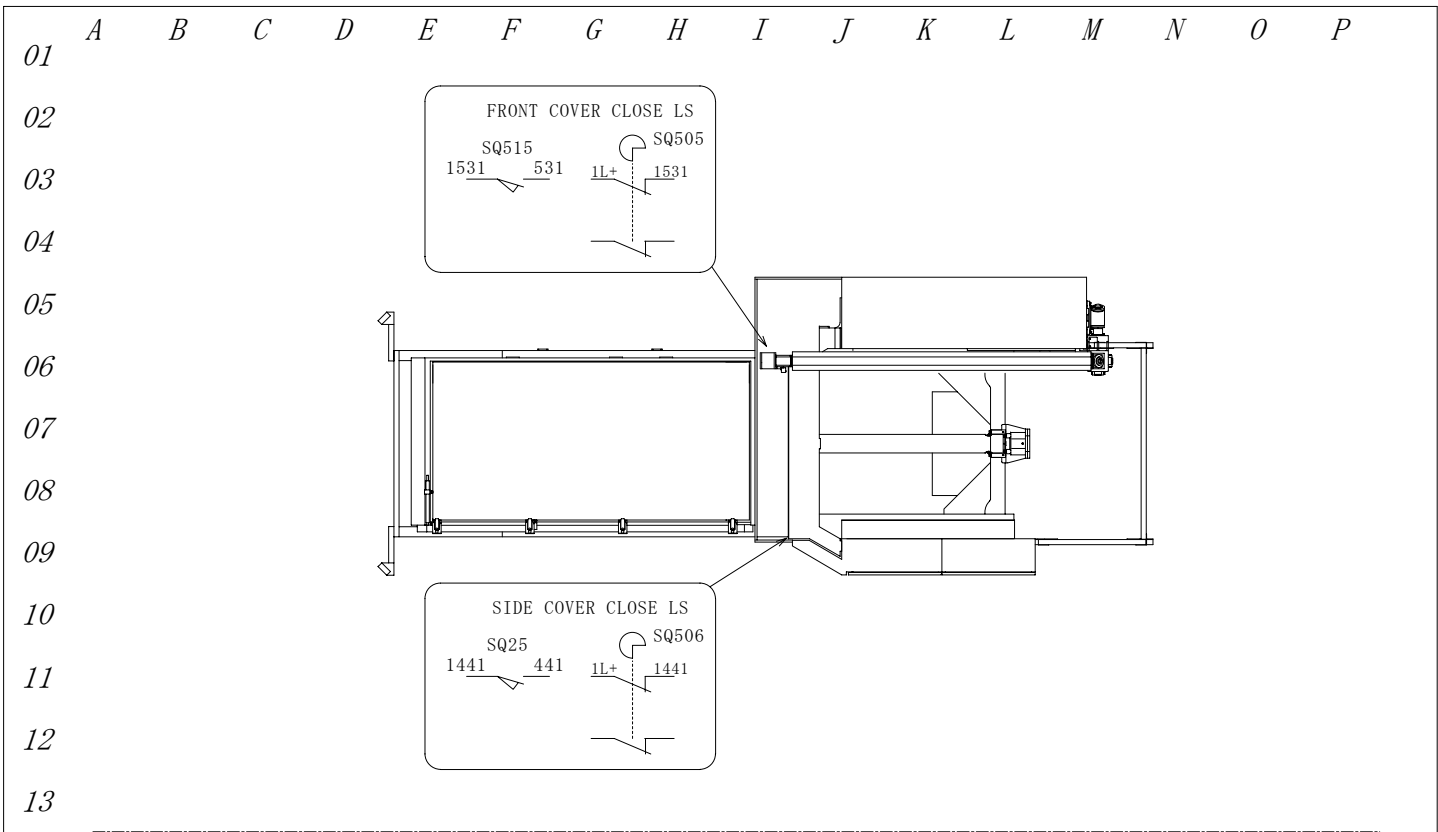

△		 YAMAZAKI MAZAK CORPORATION	APR'D BY	CHK'D BY	DRWN BY	TITLE
△			99/11/30	99/11/30	99/11/30	MACHINE COMPONENTS LAYOUT (8)
△			T. Inoue	M Okajima	M Okajima	DRWN NO. 676 001 30081,0
△			Edition Jun.03.'04 M.Okajima			

This product is subject to all the applicable Japanese Foreign Exchange and Foreign Trade Law.
 本品は『外国為替及び外国貿易法』に該当しますので外国に輸出する場合には同法に基づく許可を必要とします。

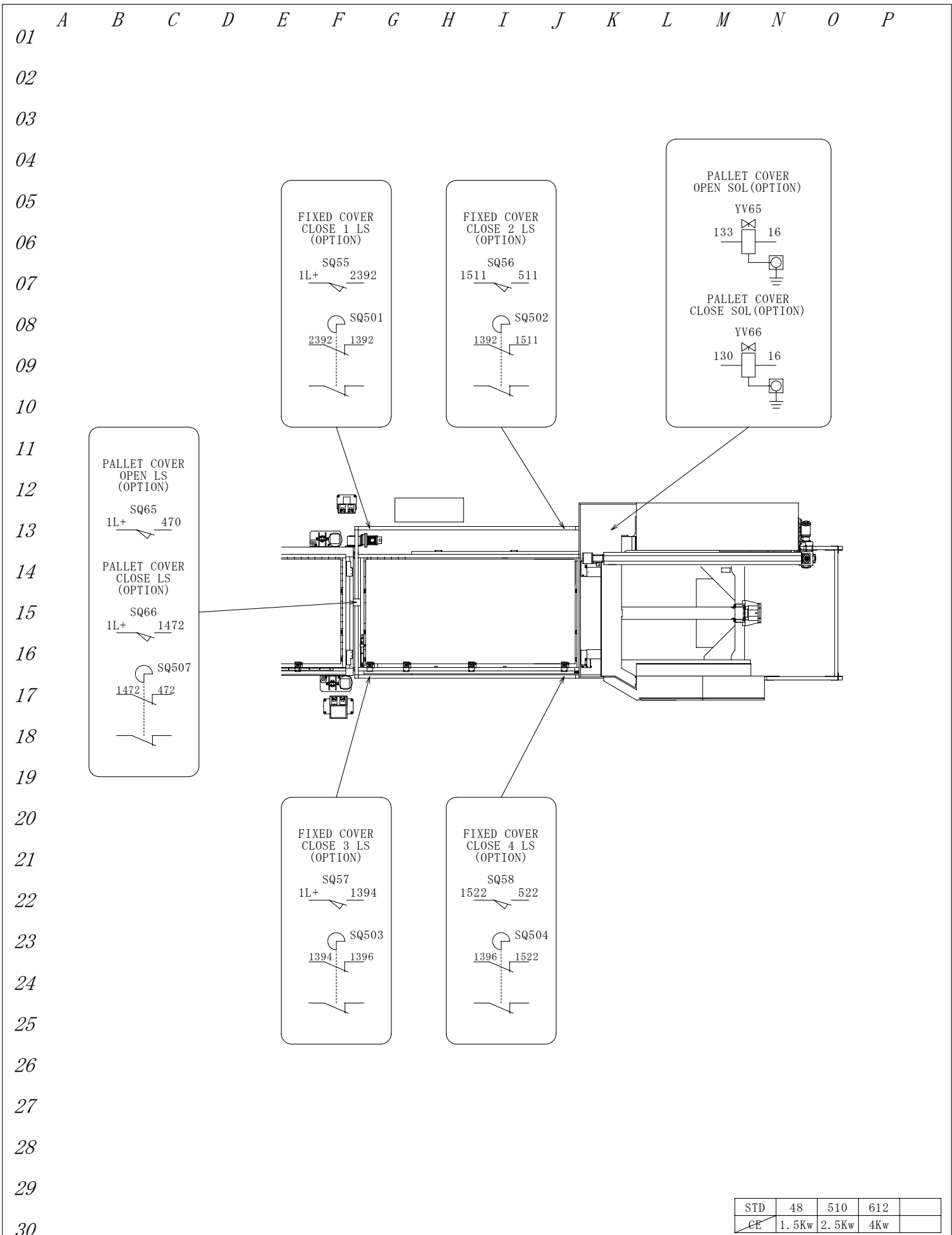

STD	48	510	612	
CE	1.5Kw	2.5Kw	4Kw	

		 YAMAZAKI MAZAK CORPORATION	APR'D BY	CHK'D BY	DRWN BY	TITLE
			04/06/03	04/06/03	04/06/03	MACHINE COMPONENTS LAYOUT (9)
			T. Inoue	M Okaji ma	M Okaji ma	DRWN NO.
						676 001 30090, 0

This product is subject to all the applicable Japanese Foreign Exchange and Foreign Trade Law.
 本品は『外国為替及び外国貿易法』に該当しますので外国に輸出する場合には同法に基づく許可を必要とします。

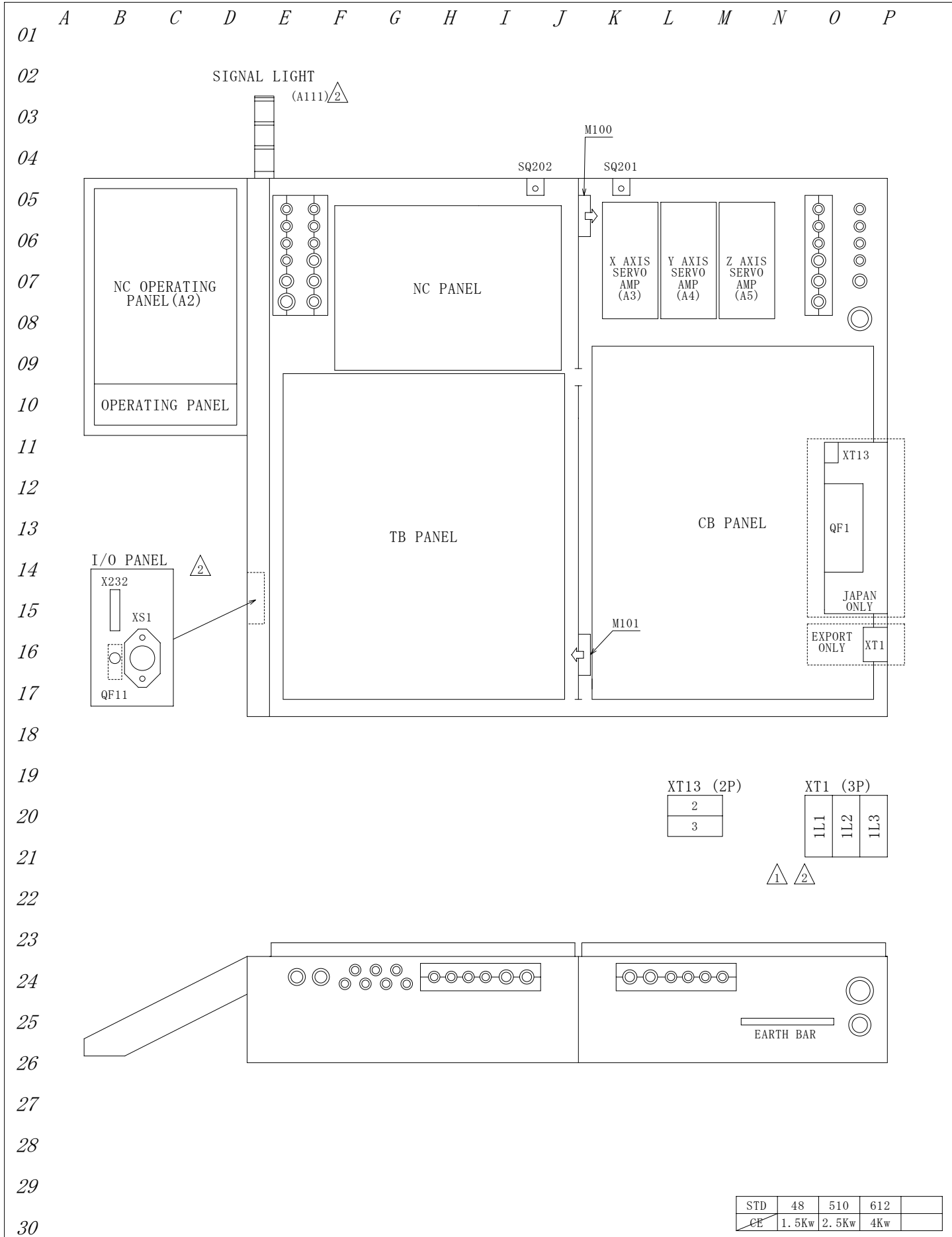

XT13 (2P)		XT1 (3P)		
2		1L1	1L2	1L3
3				

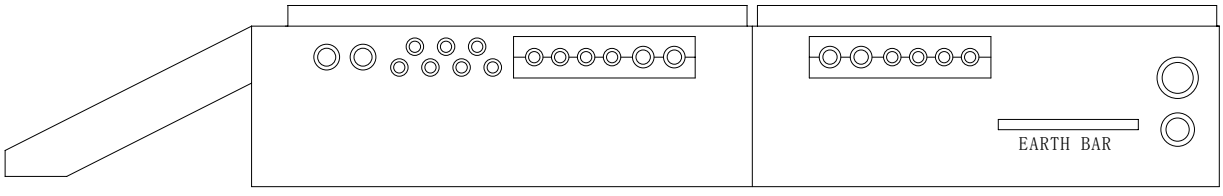

STD	48	510	612	
CE	1.5Kw	2.5Kw	4Kw	

△		 YAMAZAKI MAZAK CORPORATION	APR'D BY	CHK'D BY	DRWN BY	TITLE
△			99/11/30	99/11/30	99/11/30	CABINET LAYOUT
△			T. Inoue	M Okajima	M Okajima	
△			DRWN NO. 676 001 50012.0			

This product is subject to all the applicable Japanese Foreign Exchange and Foreign Trade Law. 本品は『外国為替及び外国貿易法』に該当しますので外国に輸出する場合には同法に基づく許可を必要とします。

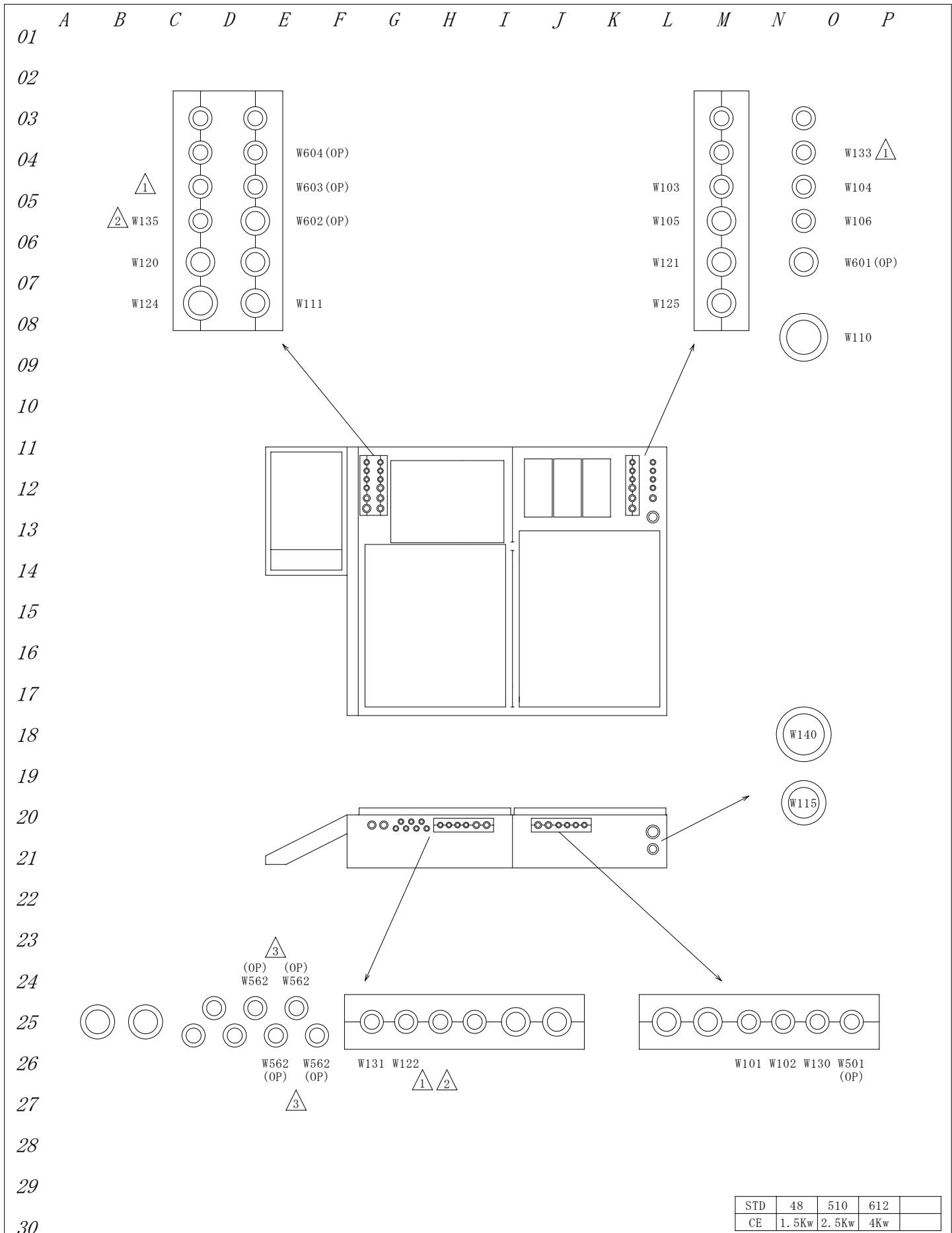

STD	48	510	612	
CE	1.5Kw	2.5Kw	4Kw	

△		 YAMAZAKI MAZAK CORPORATION	APR'D BY	CHK'D BY	DRWN BY	TITLE
△			99/11/30	99/11/30	99/11/30	CABINET INLET LAYOUT
△	Edition Aug. 10.'00 M. Okajima		T. Inoue	M Okajima	M Okajima	
△	Edition May. 23.'00 M. Okajima					DRWN NO. 676 001 50023, 0
△	Edition Mar. 27.'00 M. Okajima					

This product is subject to all the applicable Japanese Foreign Exchange and Foreign Trade Law.
 本品は『外国為替及び外国貿易法』に該当しますので外国に輸出する場合には同法に基づく許可を必要とします。

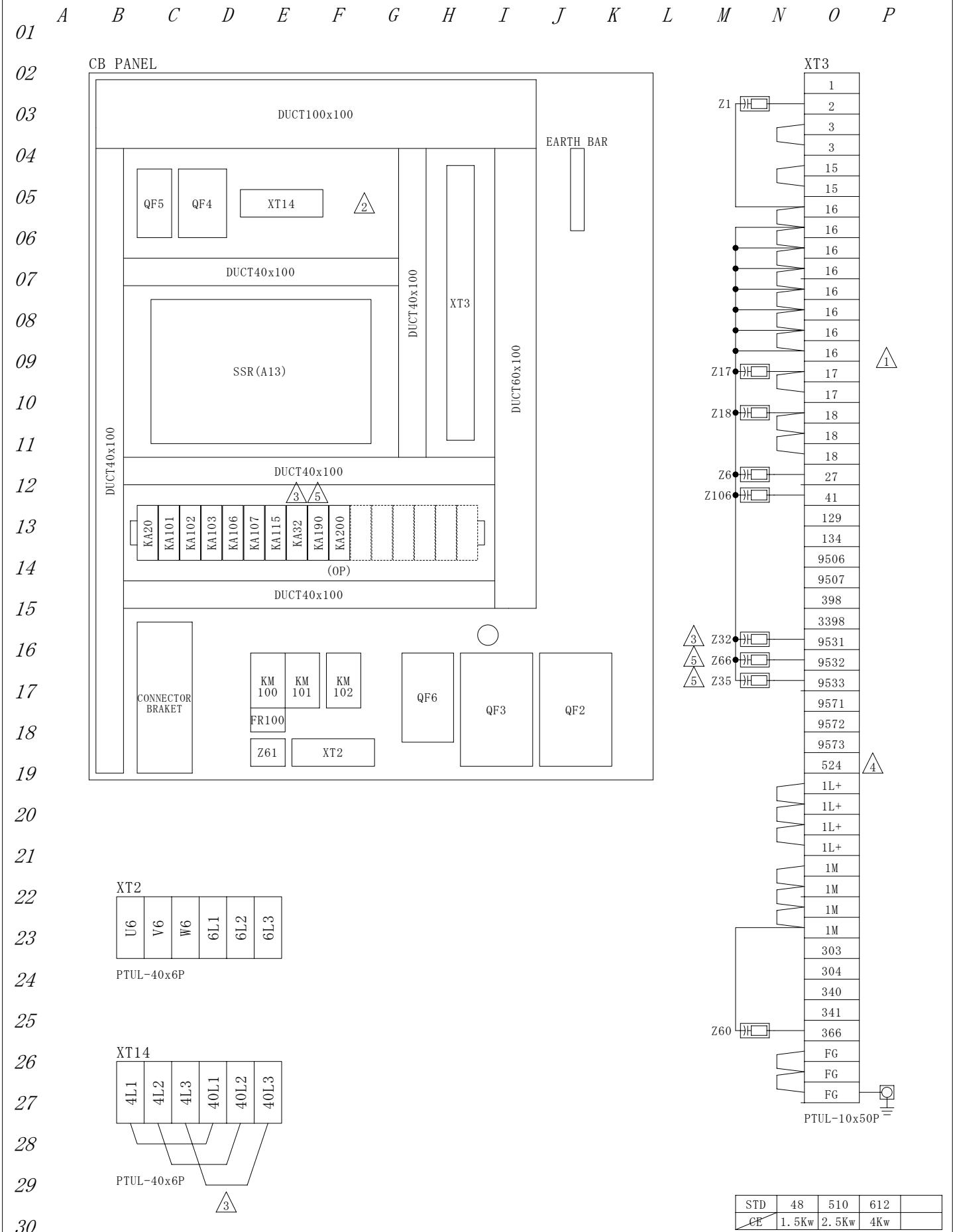

STD	48	510	612	
CE	1.5Kw	2.5Kw	4Kw	

△ Edition Oct. 10.'03 M.Okajima	 YAMAZAKI MAZAK CORPORATION	APR'D BY	CHK'D BY	DRWN BY	TITLE
△ Edition May. 06.'03 M.Okajima		99/11/30	99/11/30	99/11/30	CB PANEL LAYOUT
△ Edition Aug. 02.'00 M.Okajima		T. Inoue	M Okajima	M Okajima	
△ Edition Apr. 06.'00 M.Okajima					DRWN NO.
△ Edition Mar. 27.'00 M.Okajima					676 001 50055, 0

This product is subject to all the applicable Japanese Foreign Exchange and Foreign Trade Law.
 本品は『外国為替及び外国貿易法』に該当しますので外国に輸出する場合には同法に基づく許可を必要とします。

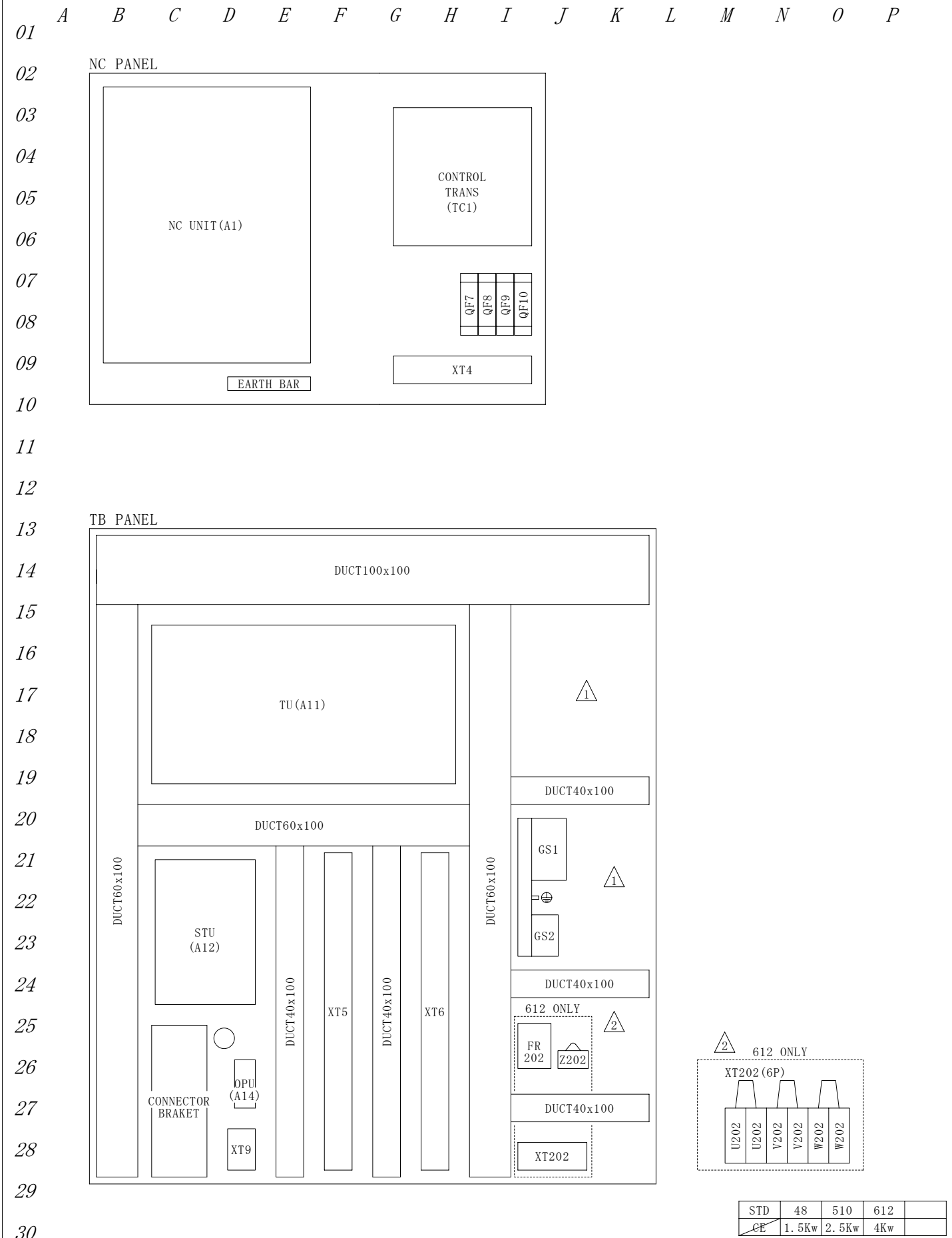

STD	48	510	612	
CE	1.5Kw	2.5Kw	4Kw	

△		 YAMAZAKI MAZAK CORPORATION	APR' D BY	CHK' D BY	DRWN BY	TITLE
△			99/11/30	99/11/30	99/11/30	NC, TB PANEL LAYOUT
△			T. Inoue	M Okajima	M Okajima	DRWN NO.
△			676 001 50062, 0			

This product is subject to all the applicable Japanese Foreign Exchange and Foreign Trade Law.
 本品は『外国為替及び外国貿易法』に該当しますので外国に輸出する場合には同法に基づく許可を必要とします。

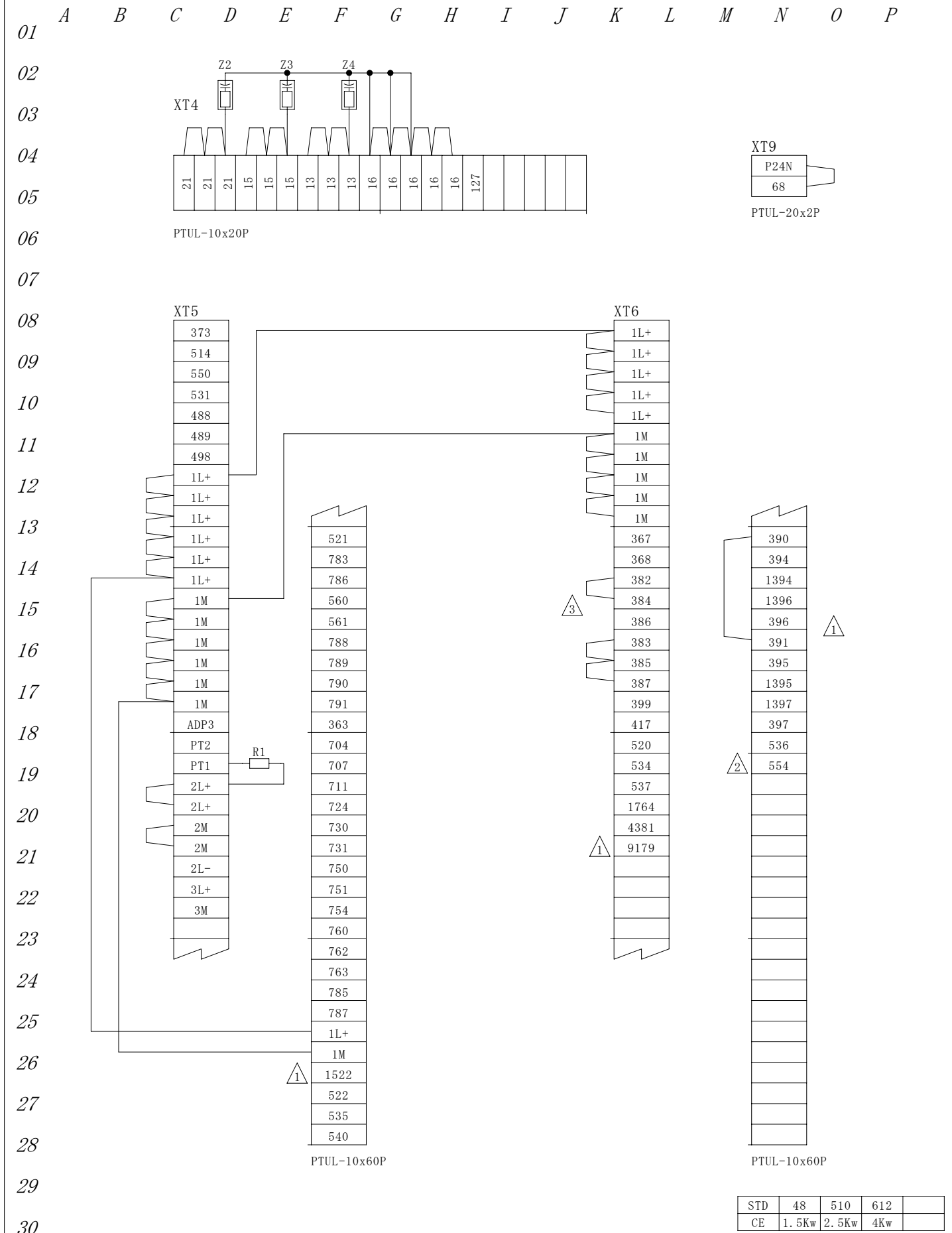

△		 YAMAZAKI MAZAK CORPORATION	APR'D BY	CHK'D BY	DRWN BY	TITLE
△			99/11/30	99/11/30	99/11/30	TERMINAL BLOCK LAYOUT
△	Edition Mar.17.'04 M.Okajima		T. Inoue	M Okajima	M Okajima	DRWN NO. 676 001 50073, 0
△	Edition Oct.10.'03 M.Okajima					
△	Edition Apr.07.'00 M.Okajima					

This product is subject to all the applicable Japanese Foreign Exchange and Foreign Trade Law.
 本品は『外国為替及び外国貿易法』に該当しますので外国に輸出する場合には同法に基づく許可を必要とします。

01	A	B	C	D	E	F	G	H	I	J	K	L	M	N	O	P																																																																																																																																																																																																																					
02	CB PANEL CONNECTOR BRACKET							X813		X24			X61																																																																																																																																																																																																																								
03								<table border="1"> <thead> <tr><th>PIN</th><th>LINE NO.</th></tr> </thead> <tbody> <tr><td>1</td><td>1L+</td></tr> <tr><td>2</td><td>300</td></tr> <tr><td>3</td><td>---</td></tr> <tr><td>4</td><td>FG</td></tr> </tbody> </table>		PIN	LINE NO.	1	1L+	2	300	3	---	4	FG	<table border="1"> <thead> <tr><th>PIN</th><th>LINE NO.</th></tr> </thead> <tbody> <tr><td>1</td><td>1L+</td></tr> <tr><td>2</td><td>---</td></tr> <tr><td>3</td><td>467</td></tr> <tr><td>4</td><td>---</td></tr> <tr><td>5</td><td>---</td></tr> <tr><td>6</td><td>426</td></tr> <tr><td>7</td><td>427</td></tr> <tr><td>8</td><td>436</td></tr> <tr><td>9</td><td>437</td></tr> <tr><td>10</td><td>435</td></tr> <tr><td>11</td><td>424</td></tr> <tr><td>12</td><td>415</td></tr> <tr><td>13</td><td>425</td></tr> <tr><td>14</td><td>---</td></tr> <tr><td>15</td><td>---</td></tr> <tr><td>16</td><td>462</td></tr> <tr><td>17</td><td>---</td></tr> <tr><td>18</td><td>1L+</td></tr> <tr><td>19</td><td>433</td></tr> <tr><td>20</td><td>434</td></tr> <tr><td>21</td><td>432</td></tr> <tr><td>22</td><td>---</td></tr> <tr><td>23</td><td>509</td></tr> <tr><td>24</td><td>518</td></tr> <tr><td>25</td><td>529</td></tr> <tr><td>26</td><td>538</td></tr> <tr><td>27</td><td>539</td></tr> <tr><td>28</td><td>548</td></tr> <tr><td>29</td><td>549</td></tr> <tr><td>30</td><td>558</td></tr> <tr><td>31</td><td>559</td></tr> <tr><td>32</td><td>562</td></tr> <tr><td>33</td><td>1M</td></tr> <tr><td>34</td><td>---</td></tr> <tr><td>35</td><td>740</td></tr> <tr><td>36</td><td>756</td></tr> <tr><td>37</td><td>416</td></tr> <tr><td>38</td><td>430</td></tr> <tr><td>39</td><td>410</td></tr> <tr><td>40</td><td>411</td></tr> <tr><td>41</td><td>412</td></tr> <tr><td>42</td><td>413</td></tr> <tr><td>43</td><td>431</td></tr> <tr><td>44</td><td>9179</td></tr> <tr><td>45</td><td>787</td></tr> <tr><td>46</td><td>9181</td></tr> <tr><td>47</td><td>9185</td></tr> <tr><td>48</td><td>9186</td></tr> <tr><td>49</td><td>---</td></tr> <tr><td>50</td><td>1M</td></tr> </tbody> </table>			PIN	LINE NO.	1	1L+	2	---	3	467	4	---	5	---	6	426	7	427	8	436	9	437	10	435	11	424	12	415	13	425	14	---	15	---	16	462	17	---	18	1L+	19	433	20	434	21	432	22	---	23	509	24	518	25	529	26	538	27	539	28	548	29	549	30	558	31	559	32	562	33	1M	34	---	35	740	36	756	37	416	38	430	39	410	40	411	41	412	42	413	43	431	44	9179	45	787	46	9181	47	9185	48	9186	49	---	50	1M	<table border="1"> <thead> <tr><th>PIN</th><th>LINE NO.</th></tr> </thead> <tbody> <tr><td>1</td><td>1L+</td></tr> <tr><td>2</td><td>1L+</td></tr> <tr><td>3</td><td>850</td></tr> <tr><td>4</td><td>851</td></tr> <tr><td>5</td><td>852</td></tr> <tr><td>6</td><td>853</td></tr> <tr><td>7</td><td>854</td></tr> <tr><td>8</td><td>855</td></tr> <tr><td>9</td><td>856</td></tr> <tr><td>10</td><td>857</td></tr> <tr><td>11</td><td>858</td></tr> <tr><td>12</td><td>859</td></tr> <tr><td>13</td><td>860</td></tr> <tr><td>14</td><td>861</td></tr> <tr><td>15</td><td>862</td></tr> <tr><td>16</td><td>863</td></tr> <tr><td>17</td><td>1L+</td></tr> <tr><td>18</td><td>1L+</td></tr> <tr><td>19</td><td>864</td></tr> <tr><td>20</td><td>865</td></tr> <tr><td>21</td><td>866</td></tr> <tr><td>22</td><td>867</td></tr> <tr><td>23</td><td>868</td></tr> <tr><td>24</td><td>869</td></tr> <tr><td>25</td><td>870</td></tr> <tr><td>26</td><td>871</td></tr> <tr><td>27</td><td>872</td></tr> <tr><td>28</td><td>873</td></tr> <tr><td>29</td><td>874</td></tr> <tr><td>30</td><td>875</td></tr> <tr><td>31</td><td>876</td></tr> <tr><td>32</td><td>877</td></tr> <tr><td>33</td><td>1M</td></tr> <tr><td>34</td><td>1M</td></tr> <tr><td>35</td><td>878</td></tr> <tr><td>36</td><td>879</td></tr> <tr><td>37</td><td>880</td></tr> <tr><td>38</td><td>881</td></tr> <tr><td>39</td><td>882</td></tr> <tr><td>40</td><td>883</td></tr> <tr><td>41</td><td>884</td></tr> <tr><td>42</td><td>885</td></tr> <tr><td>43</td><td>886</td></tr> <tr><td>44</td><td>887</td></tr> <tr><td>45</td><td>888</td></tr> <tr><td>46</td><td>889</td></tr> <tr><td>47</td><td>890</td></tr> <tr><td>48</td><td>891</td></tr> <tr><td>49</td><td>1M</td></tr> <tr><td>50</td><td>1M</td></tr> </tbody> </table>			PIN	LINE NO.	1	1L+	2	1L+	3	850	4	851	5	852	6	853	7	854	8	855	9	856	10	857	11	858	12	859	13	860	14	861	15	862	16	863	17	1L+	18	1L+	19	864	20	865	21	866	22	867	23	868	24	869	25	870	26	871	27	872	28	873	29	874	30	875	31	876	32	877	33	1M	34	1M	35	878	36	879	37	880	38	881	39	882	40	883	41	884	42	885	43	886	44	887	45	888	46	889	47	890	48	891	49	1M	50	1M
PIN								LINE NO.																																																																																																																																																																																																																													
1								1L+																																																																																																																																																																																																																													
2								300																																																																																																																																																																																																																													
3	---																																																																																																																																																																																																																																				
4	FG																																																																																																																																																																																																																																				
PIN	LINE NO.																																																																																																																																																																																																																																				
1	1L+																																																																																																																																																																																																																																				
2	---																																																																																																																																																																																																																																				
3	467																																																																																																																																																																																																																																				
4	---																																																																																																																																																																																																																																				
5	---																																																																																																																																																																																																																																				
6	426																																																																																																																																																																																																																																				
7	427																																																																																																																																																																																																																																				
8	436																																																																																																																																																																																																																																				
9	437																																																																																																																																																																																																																																				
10	435																																																																																																																																																																																																																																				
11	424																																																																																																																																																																																																																																				
12	415																																																																																																																																																																																																																																				
13	425																																																																																																																																																																																																																																				
14	---																																																																																																																																																																																																																																				
15	---																																																																																																																																																																																																																																				
16	462																																																																																																																																																																																																																																				
17	---																																																																																																																																																																																																																																				
18	1L+																																																																																																																																																																																																																																				
19	433																																																																																																																																																																																																																																				
20	434																																																																																																																																																																																																																																				
21	432																																																																																																																																																																																																																																				
22	---																																																																																																																																																																																																																																				
23	509																																																																																																																																																																																																																																				
24	518																																																																																																																																																																																																																																				
25	529																																																																																																																																																																																																																																				
26	538																																																																																																																																																																																																																																				
27	539																																																																																																																																																																																																																																				
28	548																																																																																																																																																																																																																																				
29	549																																																																																																																																																																																																																																				
30	558																																																																																																																																																																																																																																				
31	559																																																																																																																																																																																																																																				
32	562																																																																																																																																																																																																																																				
33	1M																																																																																																																																																																																																																																				
34	---																																																																																																																																																																																																																																				
35	740																																																																																																																																																																																																																																				
36	756																																																																																																																																																																																																																																				
37	416																																																																																																																																																																																																																																				
38	430																																																																																																																																																																																																																																				
39	410																																																																																																																																																																																																																																				
40	411																																																																																																																																																																																																																																				
41	412																																																																																																																																																																																																																																				
42	413																																																																																																																																																																																																																																				
43	431																																																																																																																																																																																																																																				
44	9179																																																																																																																																																																																																																																				
45	787																																																																																																																																																																																																																																				
46	9181																																																																																																																																																																																																																																				
47	9185																																																																																																																																																																																																																																				
48	9186																																																																																																																																																																																																																																				
49	---																																																																																																																																																																																																																																				
50	1M																																																																																																																																																																																																																																				
PIN	LINE NO.																																																																																																																																																																																																																																				
1	1L+																																																																																																																																																																																																																																				
2	1L+																																																																																																																																																																																																																																				
3	850																																																																																																																																																																																																																																				
4	851																																																																																																																																																																																																																																				
5	852																																																																																																																																																																																																																																				
6	853																																																																																																																																																																																																																																				
7	854																																																																																																																																																																																																																																				
8	855																																																																																																																																																																																																																																				
9	856																																																																																																																																																																																																																																				
10	857																																																																																																																																																																																																																																				
11	858																																																																																																																																																																																																																																				
12	859																																																																																																																																																																																																																																				
13	860																																																																																																																																																																																																																																				
14	861																																																																																																																																																																																																																																				
15	862																																																																																																																																																																																																																																				
16	863																																																																																																																																																																																																																																				
17	1L+																																																																																																																																																																																																																																				
18	1L+																																																																																																																																																																																																																																				
19	864																																																																																																																																																																																																																																				
20	865																																																																																																																																																																																																																																				
21	866																																																																																																																																																																																																																																				
22	867																																																																																																																																																																																																																																				
23	868																																																																																																																																																																																																																																				
24	869																																																																																																																																																																																																																																				
25	870																																																																																																																																																																																																																																				
26	871																																																																																																																																																																																																																																				
27	872																																																																																																																																																																																																																																				
28	873																																																																																																																																																																																																																																				
29	874																																																																																																																																																																																																																																				
30	875																																																																																																																																																																																																																																				
31	876																																																																																																																																																																																																																																				
32	877																																																																																																																																																																																																																																				
33	1M																																																																																																																																																																																																																																				
34	1M																																																																																																																																																																																																																																				
35	878																																																																																																																																																																																																																																				
36	879																																																																																																																																																																																																																																				
37	880																																																																																																																																																																																																																																				
38	881																																																																																																																																																																																																																																				
39	882																																																																																																																																																																																																																																				
40	883																																																																																																																																																																																																																																				
41	884																																																																																																																																																																																																																																				
42	885																																																																																																																																																																																																																																				
43	886																																																																																																																																																																																																																																				
44	887																																																																																																																																																																																																																																				
45	888																																																																																																																																																																																																																																				
46	889																																																																																																																																																																																																																																				
47	890																																																																																																																																																																																																																																				
48	891																																																																																																																																																																																																																																				
49	1M																																																																																																																																																																																																																																				
50	1M																																																																																																																																																																																																																																				
04								X814																																																																																																																																																																																																																													
05								<table border="1"> <thead> <tr><th>PIN</th><th>LINE NO.</th></tr> </thead> <tbody> <tr><td>1</td><td>1L+</td></tr> <tr><td>2</td><td>450</td></tr> <tr><td>3</td><td>451</td></tr> <tr><td>4</td><td>452</td></tr> <tr><td>5</td><td>359</td></tr> <tr><td>6</td><td>360</td></tr> <tr><td>7</td><td>1M</td></tr> <tr><td>8</td><td>FG</td></tr> </tbody> </table>		PIN	LINE NO.	1	1L+	2	450	3	451	4	452	5	359	6	360	7	1M	8	FG																																																																																																																																																																																																										
PIN	LINE NO.																																																																																																																																																																																																																																				
1	1L+																																																																																																																																																																																																																																				
2	450																																																																																																																																																																																																																																				
3	451																																																																																																																																																																																																																																				
4	452																																																																																																																																																																																																																																				
5	359																																																																																																																																																																																																																																				
6	360																																																																																																																																																																																																																																				
7	1M																																																																																																																																																																																																																																				
8	FG																																																																																																																																																																																																																																				
06																																																																																																																																																																																																																																					
07																																																																																																																																																																																																																																					
08																																																																																																																																																																																																																																					
09																																																																																																																																																																																																																																					
10																																																																																																																																																																																																																																					
11																																																																																																																																																																																																																																					
12																																																																																																																																																																																																																																					
13																																																																																																																																																																																																																																					
14																																																																																																																																																																																																																																					
15	TB PANEL CONNECTOR BRACKET							X851		X24			X61																																																																																																																																																																																																																								
16								<table border="1"> <thead> <tr><th>PIN</th><th>LINE NO.</th></tr> </thead> <tbody> <tr><td>1</td><td>1L+</td></tr> <tr><td>2</td><td>443</td></tr> <tr><td>3</td><td>446</td></tr> <tr><td>4</td><td>⊕</td></tr> </tbody> </table>		PIN	LINE NO.	1	1L+	2	443	3	446	4	⊕	<table border="1"> <thead> <tr><th>PIN</th><th>LINE NO.</th></tr> </thead> <tbody> <tr><td>1</td><td>558</td></tr> <tr><td>2</td><td>559</td></tr> <tr><td>3</td><td>562</td></tr> <tr><td>4</td><td>562</td></tr> <tr><td>5</td><td>562</td></tr> <tr><td>6</td><td>562</td></tr> <tr><td>7</td><td>562</td></tr> <tr><td>8</td><td>562</td></tr> <tr><td>9</td><td>562</td></tr> <tr><td>10</td><td>562</td></tr> <tr><td>11</td><td>562</td></tr> <tr><td>12</td><td>562</td></tr> <tr><td>13</td><td>562</td></tr> <tr><td>14</td><td>562</td></tr> <tr><td>15</td><td>562</td></tr> <tr><td>16</td><td>562</td></tr> <tr><td>17</td><td>562</td></tr> <tr><td>18</td><td>562</td></tr> <tr><td>19</td><td>562</td></tr> <tr><td>20</td><td>562</td></tr> <tr><td>21</td><td>562</td></tr> <tr><td>22</td><td>562</td></tr> <tr><td>23</td><td>562</td></tr> <tr><td>24</td><td>562</td></tr> <tr><td>25</td><td>562</td></tr> <tr><td>26</td><td>562</td></tr> <tr><td>27</td><td>562</td></tr> <tr><td>28</td><td>562</td></tr> <tr><td>29</td><td>562</td></tr> <tr><td>30</td><td>562</td></tr> <tr><td>31</td><td>562</td></tr> <tr><td>32</td><td>562</td></tr> <tr><td>33</td><td>562</td></tr> <tr><td>34</td><td>562</td></tr> <tr><td>35</td><td>562</td></tr> <tr><td>36</td><td>562</td></tr> <tr><td>37</td><td>562</td></tr> <tr><td>38</td><td>562</td></tr> <tr><td>39</td><td>562</td></tr> <tr><td>40</td><td>562</td></tr> <tr><td>41</td><td>562</td></tr> <tr><td>42</td><td>562</td></tr> <tr><td>43</td><td>562</td></tr> <tr><td>44</td><td>562</td></tr> <tr><td>45</td><td>562</td></tr> <tr><td>46</td><td>562</td></tr> <tr><td>47</td><td>562</td></tr> <tr><td>48</td><td>562</td></tr> <tr><td>49</td><td>562</td></tr> <tr><td>50</td><td>562</td></tr> </tbody> </table>			PIN	LINE NO.	1	558	2	559	3	562	4	562	5	562	6	562	7	562	8	562	9	562	10	562	11	562	12	562	13	562	14	562	15	562	16	562	17	562	18	562	19	562	20	562	21	562	22	562	23	562	24	562	25	562	26	562	27	562	28	562	29	562	30	562	31	562	32	562	33	562	34	562	35	562	36	562	37	562	38	562	39	562	40	562	41	562	42	562	43	562	44	562	45	562	46	562	47	562	48	562	49	562	50	562	<table border="1"> <thead> <tr><th>PIN</th><th>LINE NO.</th></tr> </thead> <tbody> <tr><td>1</td><td>1L+</td></tr> <tr><td>2</td><td>1441</td></tr> <tr><td>3</td><td>1441</td></tr> <tr><td>4</td><td>441</td></tr> </tbody> </table>			PIN	LINE NO.	1	1L+	2	1441	3	1441	4	441																																																																																												
PIN								LINE NO.																																																																																																																																																																																																																													
1								1L+																																																																																																																																																																																																																													
2								443																																																																																																																																																																																																																													
3	446																																																																																																																																																																																																																																				
4	⊕																																																																																																																																																																																																																																				
PIN	LINE NO.																																																																																																																																																																																																																																				
1	558																																																																																																																																																																																																																																				
2	559																																																																																																																																																																																																																																				
3	562																																																																																																																																																																																																																																				
4	562																																																																																																																																																																																																																																				
5	562																																																																																																																																																																																																																																				
6	562																																																																																																																																																																																																																																				
7	562																																																																																																																																																																																																																																				
8	562																																																																																																																																																																																																																																				
9	562																																																																																																																																																																																																																																				
10	562																																																																																																																																																																																																																																				
11	562																																																																																																																																																																																																																																				
12	562																																																																																																																																																																																																																																				
13	562																																																																																																																																																																																																																																				
14	562																																																																																																																																																																																																																																				
15	562																																																																																																																																																																																																																																				
16	562																																																																																																																																																																																																																																				
17	562																																																																																																																																																																																																																																				
18	562																																																																																																																																																																																																																																				
19	562																																																																																																																																																																																																																																				
20	562																																																																																																																																																																																																																																				
21	562																																																																																																																																																																																																																																				
22	562																																																																																																																																																																																																																																				
23	562																																																																																																																																																																																																																																				
24	562																																																																																																																																																																																																																																				
25	562																																																																																																																																																																																																																																				
26	562																																																																																																																																																																																																																																				
27	562																																																																																																																																																																																																																																				
28	562																																																																																																																																																																																																																																				
29	562																																																																																																																																																																																																																																				
30	562																																																																																																																																																																																																																																				
31	562																																																																																																																																																																																																																																				
32	562																																																																																																																																																																																																																																				
33	562																																																																																																																																																																																																																																				
34	562																																																																																																																																																																																																																																				
35	562																																																																																																																																																																																																																																				
36	562																																																																																																																																																																																																																																				
37	562																																																																																																																																																																																																																																				
38	562																																																																																																																																																																																																																																				
39	562																																																																																																																																																																																																																																				
40	562																																																																																																																																																																																																																																				
41	562																																																																																																																																																																																																																																				
42	562																																																																																																																																																																																																																																				
43	562																																																																																																																																																																																																																																				
44	562																																																																																																																																																																																																																																				
45	562																																																																																																																																																																																																																																				
46	562																																																																																																																																																																																																																																				
47	562																																																																																																																																																																																																																																				
48	562																																																																																																																																																																																																																																				
49	562																																																																																																																																																																																																																																				
50	562																																																																																																																																																																																																																																				
PIN	LINE NO.																																																																																																																																																																																																																																				
1	1L+																																																																																																																																																																																																																																				
2	1441																																																																																																																																																																																																																																				
3	1441																																																																																																																																																																																																																																				
4	441																																																																																																																																																																																																																																				
17																																																																																																																																																																																																																																					
18																																																																																																																																																																																																																																					
19																																																																																																																																																																																																																																					
20																																																																																																																																																																																																																																					
21																																																																																																																																																																																																																																					
22																																																																																																																																																																																																																																					
23																																																																																																																																																																																																																																					
24																																																																																																																																																																																																																																					
25																																																																																																																																																																																																																																					
26																																																																																																																																																																																																																																					
27																																																																																																																																																																																																																																					
28																																																																																																																																																																																																																																					
29																																																																																																																																																																																																																																					
30																																																																																																																																																																																																																																					

STD	48	510	612	
CE	1.5Kw	2.5Kw	4Kw	

△		 YAMAZAKI MAZAK CORPORATION	APR'D BY	CHK'D BY	DRWN BY	TITLE
△			99/11/30	99/11/30	99/11/30	CONNECTOR BRACKET LAYOUT
△			T. Inoue	M Okajima	M Okajima	
△			DRWN NO. 676 001 50082, 0			

This product is subject to all the applicable Japanese Foreign Exchange and Foreign Trade Law.
 本品は『外国為替及び外国貿易法』に該当しますので外国に輸出する場合には同法に基づく許可を必要とします。

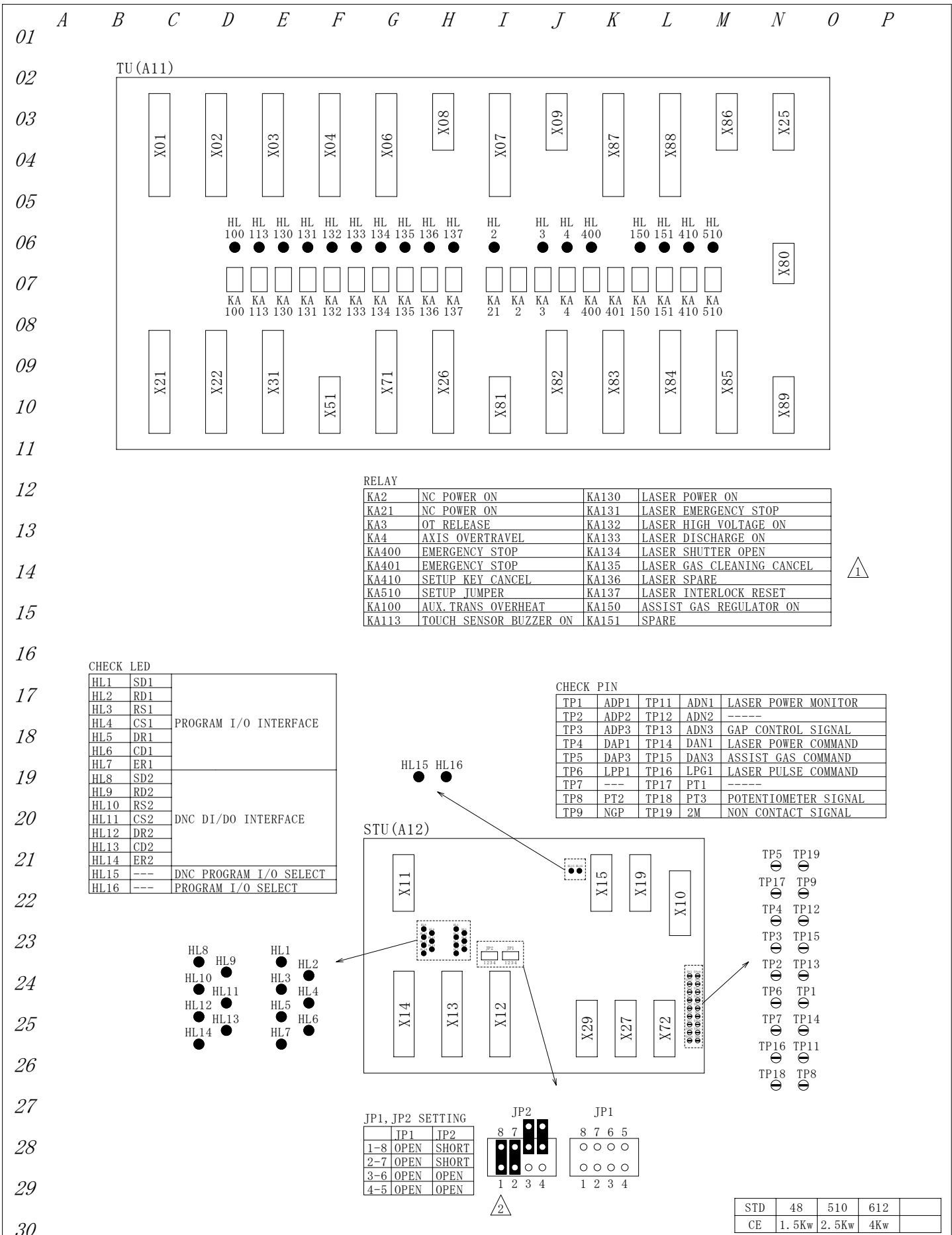

△		 YAMAZAKI MAZAK CORPORATION	APR'D BY	CHK'D BY	DRWN BY	TITLE
△			99/11/30	99/11/30	99/11/30	TU (A11), STU (A12) LAYOUT
△			T. Inoue	M Okajima	M Okajima	DRWN NO.
△			676 001 50102.0			

This product is subject to all the applicable Japanese Foreign Exchange and Foreign Trade Law.
 本品は『外国為替及び外国貿易法』に該当しますので外国に輸出する場合には同法に基づく許可を必要とします。

	A	B	C	D	E	F	G	H	I	J	K	L	M	N	O	P
01																
02	X01		X02		X03		X04		X06		X07		X08			
03	PIN	LINE NO.	PIN	LINE NO.	PIN	LINE NO.	PIN	LINE NO.	PIN	LINE NO.	PIN	LINE NO.	PIN	LINE NO.	PIN	LINE NO.
04	1	406	1	446	1	486	1	526	1	707	1	757	1	(1L+)		
05	2	403	2	443	2	483	2	523	2	705	2	755	2	708		
06	3	400	3	440	3	480	3	520	3	702	3	752	3	709		
07	4	---	4	---	4	488	4	529	4	1L+	4	1L+	4	718		
08	5	---	5	---	5	489	5	538	5	717	5	767	5	719		
09	6	413	6	453	6	493	6	533	6	714	6	764	6	728		
10	7	410	7	450	7	490	7	530	7	1L+	7	1L+	7	(1L+)		
11	8	---	8	---	8	498	8	539	8	727	8	777	8	729		
12	9	---	9	---	9	508	9	548	9	724	9	774	9	738		
13	10	426	10	466	10	506	10	546	10	1L+	10	1L+	10	739		
14	11	423	11	463	11	503	11	543	11	737	11	787	11	---		
15	12	420	12	460	12	500	12	540	12	735	12	785	12	---		
16	13	---	13	---	13	509	13	549	13	732	13	782	13	---		
17	14	---	14	---	14	518	14	558	14	1L+	14	1L+	14	(1M)		
18	15	433	15	473	15	513	15	553	15	747	15	748	15	---		
19	16	430	16	470	16	510	16	550	16	744	16	749	16	---		
20	17	---	17	---	17	519	17	559	17	741	17	758	17	---		
21	18	---	18	---	18	528	18	562	18	1L+	18	759	18	---		
22	19	404	19	444	19	484	19	524	19	704	19	754	19	---		
23	20	401	20	441	20	481	20	521	20	701	20	751	20	(1M)		
24	21	(1M)	21	(1M)	21	(1M)	21	(1M)	21	716	21	766				
25	22	416	22	456	22	496	22	536	22	713	22	763				
26	23	(414)	23	454	23	494	23	534	23	711	23	761				
27	24	411	24	451	24	491	24	531	24	710	24	760				
28	25	---	25	---	25	9109	25	560	25	726	25	776				
29	26	---	26	---	26	9110	26	561	26	723	26	773				
30	27	424	27	464	27	504	27	544	27	721	27	771				
31	28	421	28	461	28	501	28	541	28	720	28	770				
32	29	(1M)	29	(1M)	29	(1M)	29	(1M)	29	734	29	784				
33	30	436	30	476	30	516	30	556	30	731	30	781	X09			
34	31	434	31	(474)	31	514	31	554	31	746	31	768	PIN	LINE NO.		
35	32	431	32	471	32	511	32	551	32	743	32	788	1	465		
36	33	407	33	447	33	487	33	527	33	706	33	756	2	9130		
37	34	405	34	445	34	485	34	525	34	703	34	753	3	9131		
38	35	402	35	68	35	482	35	522	35	700	35	750	4	550		
39	36	(1M)	36	(1M)	36	1M	36	1M	36	1M	36	1M	5	---		
40	37	417	37	457	37	497	37	537	37	715	37	765	6	---		
41	38	415	38	455	38	495	38	535	38	712	38	762	7	1L+		
42	39	412	39	452	39	492	39	532	39	1M	39	1M	8	---		
43	40	(1M)	40	(1M)	40	1M	40	1M	40	725	40	775	9	---		
44	41	(1M)	41	(1M)	41	1M	41	1M	41	722	41	772	10	---		
45	42	427	42	467	42	507	42	547	42	1M	42	1M	11	---		
46	43	425	43	465	43	505	43	545	43	736	43	786	12	---		
47	44	422	44	462	44	502	44	542	44	733	44	783	13	---		
48	45	1M	45	1M	45	1M	45	1M	45	730	45	780	14	---		
49	46	437	46	(477)	46	517	46	557	46	1M	46	1M	15	---		
50	47	435	47	(475)	47	515	47	555	47	745	47	789	16	---		
51	48	432	48	472	48	512	48	552	48	742	48	790	17	---		
52	49	1M	49	1M	49	1M	49	1M	49	740	49	791	18	---		
53	50	1M	50	1M	50	1M	50	1M	50	1M	50	351	19	---		
54																
55																
56																
57																
58																
59																
60																

STD	48	510	612	
CE	1.5Kw	2.5Kw	4Kw	

△		 YAMAZAKI MAZAK CORPORATION	APR'D BY	CHK'D BY	DRWN BY	TITLE
△			99/11/30	99/11/30	99/11/30	TU (A11)
△			T. Inoue	M Okaji ma	M Okaji ma	CONNECTOR TABLE(1)
△						DRWN NO.
△						676 001 50110, 0

This product is subject to all the applicable Japanese Foreign Exchange and Foreign Trade Law.
 本品は『外国為替及び外国貿易法』に該当しますので外国に輸出する場合には同法に基づく許可を必要とします。

	A	B	C	D	E	F	G	H	I	J	K	L	M	N	O	P
01																
02	X80		X82		X83		X84		X85		X86		X87		X88	
03	PIN LINE NO.		PIN LINE NO.		PIN LINE NO.		PIN LINE NO.		PIN LINE NO.		PIN LINE NO.		PIN LINE NO.		PIN LINE NO.	
04	1 1L+		1 1L+		1 710		1 1L+		1 382		1 1L+		1 1L+		1 1L+	
05	2 1L+		2 1L+		2 757		2 1L+		2 383		2 ---		2 1L+		2 1L+	
06	3 1L+		3 301		3 712		3 1L+		3 384		3 465		3 522		3 9138	
07	4 ⊕		4 302		4 713		4 1L+		4 385		4 463		4 524		4 9139	
08	5 1M		5 304		5 737		5 386		5 386		5 464		5 525		5 9140	
09	6 1M		6 305		6 744		6 387		6 387		6 ---		6 532		6 9141	
10	7 1M		7 306		7 732		7 4381		7 368		7 1M		7 533		7 9142	
11	8 (⊕)		8 306		8 733		8 764		8 367		8 ---		8 535		8 9143	
12			9 305		9 734		9 764		9 1L+		9 ---		9 540		9 9144	
13			10 1L+		10 735		10 1764		10 514		10 465		10 767		10 9145	
14			11 369		11 736		11 370		11 1L+		11 ---		11 772		11 9146	
15			12 1L+		12 745		12 702		12 521		12 ---		12 776		12 373	
16			13 370		13 725		13 367		13 783		13 1M		13 777		13 767	
17			14 702		14 742		14 368		14 786		14 727		14 9130		14 748	
18			15 702		15 741		15 367		15 1M		15 ---		15 9131		15 749	
19			16 703		16 748		16 702		16 P24N		16 418		16 550		16 758	
20			17 1L+		17 749		17 1L+		17 68		17 419		17 1L+		17 1L+	
21			18 1L+		18 758		18 1L+		18 9175		18 ⊕		18 1L+		18 1L+	
22			19 351		19 1M		19 9151		19 1L+		19 ---		19 (414)		19 759	
23			20 752		20 1M		20 9152		20 443		20 1L+		20 488		20 768	
24			21 753		21 714		21 9153		21 446		21 446		21 489		21 9172	
25			22 720		22 715		22 ---		22 ⊕		22 ⊕		22 498		22 9173	
26			23 721		23 716		23 ---		23 1L+		23 1L+		23 508		23 9174	
27			24 771		24 766		24 ---		24 1441		24 1441		24 509		24 9175	
28			25 755		25 717		25 ---		25 1441		25 1441		25 518		25 9176	
29			26 765		26 722		26 ---		26 441		26 441		26 519		26 9177	
30			27 770		27 743		27 ---		27 394		27 394		27 528		27 9178	
31			28 774		28 782		28 ---		28 395		28 395		28 560		28 9179	
32			29 9141		29 775		29 ---		29 396		29 396		29 561		29 787	
33	X81		30 9142		30 773		30 9162		30 397		X89		30 748		30 9181	
34	PIN LINE NO.		31 9143		31 759		31 9163		31 1L+		PIN LINE NO.		31 749		31 ---	
35	1 1L+		32 9144		32 768		32 9164		32 531		1 1L+		32 758		32 509	
36	2 524		33 1M		33 706		33 1M		33 1L+		2 466		33 1M		33 1M	
37	3 525		34 1M		34 705		34 1M		34 406		3 476		34 1M		34 1M	
38	4 1L+		35 767		35 781		35 537		35 407		4 455		35 759		35 518	
39	5 544		36 1M		36 ---		36 534		36 423		5 723		36 768		36 9185	
40	6 543		37 373		37 ---		37 417		37 358		6 761		37 788		37 9186	
41	7 1L+		38 1373		38 ---		38 520		38 9172		7 1L+		38 789		38 519	
42	8 1L+		39 1L+		39 1M		39 389		39 9173		8 418		39 790		39 528	
43	9 300		40 372		40 1M		40 399		40 9174		9 419		40 791		40 9189	
44	10 1L+		41 1M		41 ---		41 389		41 2L+		10 554		41 ---		41 9190	
45	11 450		42 374		42 ---		42 1L+		42 2L-		11 555		42 9150		42 9191	
46	12 451		43 1374		43 ---		43 536		43 2M		12 3L+		43 9151		43 9192	
47	13 452		44 2374		44 ---		44 390		44 3L+		13 3M		44 9152		44 9193	
48	14 1M		45 9145		45 ---		45 391		45 3M		14 1M		45 9153		45 9194	
49	15 1L+		46 9146		46 ---		46 396		46 3L+		15 3L+		46 9162		46 9195	
50	16 523		47 373		47 ---		47 397		47 3M		16 3M		47 9163		47 9196	
51	17 9138		48 767		48 ---		48 9150		48 1L+		17 3L+		48 9164		48 ---	
52	18 9139		49 1M		49 ---		49 1M		49 1M		18 2M		49 1M		49 1M	
53	19 9140		50 1M		50 ---		50 1M		50 1M		19 2L-		50 1M		50 1M	
54	20 1M										20 1M					



STD	48	510	612	
CE	1.5Kw	2.5Kw	4Kw	

△		 YAMAZAKI MAZAK CORPORATION	APR' D BY	CHK' D BY	DRWN BY	TITLE
△			99/11/30	99/11/30	99/11/30	TU (A11) CONNECTOR TABLE (2)
△			T. Inoue	M Okajima	M Okajima	DRWN NO. 676 001 50121, 0
△			Edition Apr. 07.'00 M. Okajima			

This product is subject to all the applicable Japanese Foreign Exchange and Foreign Trade Law.
 本品は『外国為替及び外国貿易法』に該当しますので外国に輸出する場合には同法に基づく許可を必要とします。

	A	B	C	D	E	F	G	H	I	J	K	L	M	N	O	P
01																
02	X21		X22		X25		X26		X31		X51		X71			
03	PIN LINE NO.		PIN LINE NO.		PIN LINE NO.		PIN LINE NO.		PIN LINE NO.		PIN LINE NO.		PIN LINE NO.			
04	1 1L+		1 1L+		1 1L+		1 1L+		1 1L+		1 1L+		1 1L+			
05	2 1L+		2 1L+		2 382		2 1L+		2 1L+		2 ---		2 1L+			
06	3 380		3 467		3 383		3 ---		3 ---		3 444		3 ---			
07	4 381		4 (477)		4 384		4 310		4 400		4 445		4 404			
08	5 382		5 351		5 385		5 311		5 401		5 456		5 405			
09	6 383		6 426		6 517		6 312		6 402		6 ---		6 ---			
10	7 301		7 427		7 1L+		7 313		7 ---		7 1L+		7 358			
11	8 302		8 436		8 515		8 320		8 403		8 457		8 422			
12	9 304		9 437		9 516		9 314		9 358		9 ---		9 ---			
13	10 305		10 435		10 440		10 315		10 420		10 400		10 541			
14	11 306		11 424		11 532		11 316		11 421		11 401		11 542			
15	12 389		12 415		12 533		12 321		12 ---		12 ---		12 ---			
16	13 363		13 425		13 519		13 317		13 530		13 358		13 453			
17	14 9176		14 (474)		14 1M		14 318		14 544		14 1M		14 454			
18	15 9177		15 (475)		15 528		15 319		15 543		15 ---		15 ---			
19	16 9178		16 462		16 747		16 ---		16 ---		16 420		16 ---			
20	17 1L+		17 1L+		17 780		17 1L+		17 1L+		17 9192		17 1L+			
21	18 1L+		18 1L+		18 776		18 1L+		18 1L+		18 9193		18 1L+			
22	19 ---		19 433		19 777		19 480		19 470		19 ---		19 ---			
23	20 ---		20 434		20 1M		20 481		20 ---		20 1M		20 460			
24	21 ---		21 432				21 482		21 471				21 ---			
25	22 ---		22 389				22 483		22 ---				22 461			
26	23 ---		23 509				23 484		23 472				23 ---			
27	24 ---		24 518				24 485		24 ---				24 545			
28	25 ---		25 529				25 486		25 473				25 ---			
29	26 ---		26 538				26 487		26 512				26 546			
30	27 ---		27 539				27 490		27 ---				27 ---			
31	28 ---		28 548				28 491		28 513				28 547			
32	29 ---		29 549				29 492		29 ---				29 ---			
33	30 ---		30 558				30 493		30 511				30 550			
34	31 ---		31 559				31 494		31 ---				31 ---			
35	32 ---		32 562				32 495		32 510				32 ---			
36	33 1M		33 1M				33 1M		33 1M				33 1M			
37	34 1M		34 1M				34 1M		34 1M				34 1M			
38	35 416		35 740				35 ---		35 ---				35 ---			
39	36 430		36 756				36 496		36 531				36 552			
40	37 410		37 750				37 497		37 390				37 556			
41	38 411		38 751				38 500		38 391				38 ---			
42	39 412		39 754				39 501		39 ---				39 551			
43	40 413		40 711				40 502		40 394				40 553			
44	41 431		41 730				41 503		41 395				41 ---			
45	42 785		42 731				42 504		42 526				42 557			
46	43 787		43 724				43 505		43 527				43 9194			
47	44 704		44 762				44 506		44 ---				44 ---			
48	45 707		45 763				45 507		45 9189				45 9195			
49	46 9179		46 760				46 509		46 9190				46 9196			
50	47 787	△	47 9185				47 9110		47 9191				47 ---			
51	48 9181		48 9186				48 ---		48 ---				48 ---			
52	49 1M		49 1M				49 1M		49 1M				49 1M			
53	50 1M		50 1M				50 1M		50 1M				50 1M			

STD	48	510	612	
CE	1.5Kw	2.5Kw	4Kw	

△		 YAMAZAKI MAZAK CORPORATION	APR' D BY	CHK' D BY	DRWN BY	TITLE
△			99/11/30	99/11/30	99/11/30	TU (A11) CONNECTOR TABLE (3)
△			T. Inoue	M Okaji ma	M Okaji ma	DRWN NO. 676 001 50131, 0
△			Edition Apr. 07. '00 M. Okajima			

This product is subject to all the applicable Japanese Foreign Exchange and Foreign Trade Law.
 本品は『外国為替及び外国貿易法』に該当しますので外国に輸出する場合には同法に基づく許可を必要とします。

	A	B	C	D	E	F	G	H	I	J	K	L	M	N	O	P
01																
02	X10		X15		X19		X27		X29		X72					
03	PIN LINE NO.		PIN LINE NO.		PIN LINE NO.		PIN LINE NO.		PIN LINE NO.		PIN LINE NO.					
04	1 2L+		1 (BOFF1)		1 1L+		1 (BOFF1)		1 723		1 2L+					
05	2 2L-		2 ADP1		2 466		2 ADP1		2 466		2 SDIN					
06	3 ---		3 ADP2		3 476		3 ADP2		3 PT1		3 DAP3					
07	4 3L+		4 (MDIR1)		4 455		4 (MDIR1)		4 PT3		4 PT1					
08	5 3L+		5 ADP3		5 723		5 ---		5 PT2		5 ---					
09	6 3L+		6 DAP1		6 761		6 DAP1		6 476		6 NGP					
10	7 ---		7 DAP3		7 1L+		7 (1L+)		7 2L+		7 418					
11	8 ⊕		8 ---		8 418		8 (554)		8 NGP		8 2M					
12	9 2M		9 LPP1		9 419		9 LPP1		9 GOF		9 SKIN					
13	10 ---		10 (SG)		10 554		10 (SG)		10 SDIN		10 PT2					
14	11 ---		11 (MDIR2)		11 555		11 (MDIR2)		11 SKIN		11 ---					
15	12 3M		12 ADN1		12 3L+		12 ADN1		12 SSIN		12 ---					
16	13 3M		13 ADN2		13 3M		13 ADN2		13 2L-		13 ⊕					
17	14 3M		14 (BOFF2)		14 1M		14 (BOFF2)		14 455		14 2L-					
18	15 ---		15 ADN3		15 3L+		15 (555)		15 ⊕		15 SSIN					
19	16 (⊕)		16 DAN1		16 3M		16 DAN1		16 1L+		16 DAN3					
20			17 DAN3		17 2L+		17 ---		17 1M		17 PT3					
21			18 ---		18 2M		18 ---		18 ADP3		18 PT3					
22			19 LPG1		19 2L-		19 LPG1		19 ADN3		19 GOF					
23			20 ⊕		20 1M		20 ⊕		20 2M		20 419					
24																
25																
26																
27																
28																
29																
30																

X11

PIN	LINE NO.
1	⊕
2	SD1
3	RD1
4	RS1
5	CS1
6	DR1
7	SG1
8	CD1
9	ER1
10	---
11	⊕
12	SD2
13	RD2
14	RS2
15	CS2
16	DR2
17	SG2
18	CD2
19	ER2
20	---

X12

PIN	LINE NO.
1	⊕
2	SD11
3	RD11
4	RS11
5	CS11
6	DR11
7	SG11
8	CD11
9	---
10	---
11	---
12	---
13	---
14	---
15	3L+
16	---
17	---
18	---
19	---
20	ER11
21	---
22	---
23	---
24	---
25	---

X13

PIN	LINE NO.
1	⊕
2	SD12
3	RD12
4	RS12
5	CS12
6	DR12
7	SG12
8	CD12
9	---
10	---
11	---
12	---
13	---
14	---
15	3L+
16	---
17	---
18	---
19	---
20	ER12
21	---
22	---
23	---
24	---
25	---

X14

PIN	LINE NO.
1	⊕
2	SD22
3	RD22
4	RS22
5	CS22
6	DR22
7	SG22
8	CD22
9	---
10	---
11	---
12	---
13	---
14	---
15	3L+
16	---
17	---
18	---
19	---
20	ER22
21	---
22	---
23	---
24	---
25	---

STD	48	510	612	
CE	1.5Kw	2.5Kw	4Kw	

△		 YAMAZAKI MAZAK CORPORATION	APR' D BY	CHK' D BY	DRWN BY	TITLE
△			99/11/30	99/11/30	99/11/30	STU(A12) CONNECTOR TABLE
△			T. Inoue	M Okaji ma	M Okaji ma	DRWN NO. 676 001 50140, 0
△						
△						

This product is subject to all the applicable Japanese Foreign Exchange and Foreign Trade Law.
 本品は『外国為替及び外国貿易法』に該当しますので外国に輸出する場合には同法に基づく許可を必要とします。

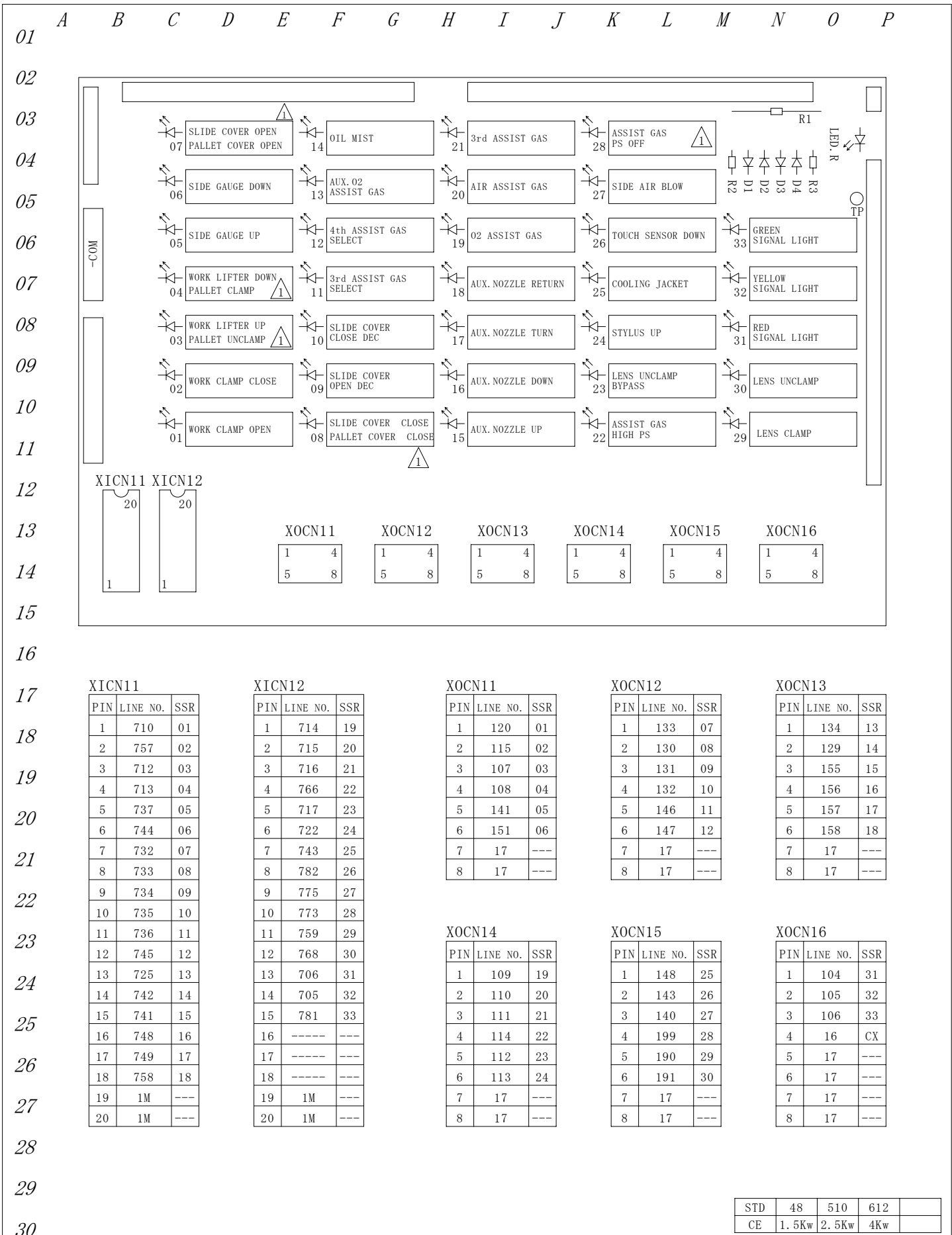

XICN11 XICN12

1	20
20	1

XOCN11	XOCN12	XOCN13	XOCN14	XOCN15	XOCN16
1 4	1 4	1 4	1 4	1 4	1 4
5 8	5 8	5 8	5 8	5 8	5 8

PIN	LINE NO.	SSR
1	710	01
2	757	02
3	712	03
4	713	04
5	737	05
6	744	06
7	732	07
8	733	08
9	734	09
10	735	10
11	736	11
12	745	12
13	725	13
14	742	14
15	741	15
16	748	16
17	749	17
18	758	18
19	1M	---
20	1M	---

PIN	LINE NO.	SSR
1	714	19
2	715	20
3	716	21
4	766	22
5	717	23
6	722	24
7	743	25
8	782	26
9	775	27
10	773	28
11	759	29
12	768	30
13	706	31
14	705	32
15	781	33
16	-----	---
17	-----	---
18	-----	---
19	1M	---
20	1M	---

PIN	LINE NO.	SSR
1	120	01
2	115	02
3	107	03
4	108	04
5	141	05
6	151	06
7	17	---
8	17	---

PIN	LINE NO.	SSR
1	133	07
2	130	08
3	131	09
4	132	10
5	146	11
6	147	12
7	17	---
8	17	---

PIN	LINE NO.	SSR
1	134	13
2	129	14
3	155	15
4	156	16
5	157	17
6	158	18
7	17	---
8	17	---

PIN	LINE NO.	SSR
1	109	19
2	110	20
3	111	21
4	114	22
5	112	23
6	113	24
7	17	---
8	17	---

PIN	LINE NO.	SSR
1	148	25
2	143	26
3	140	27
4	199	28
5	190	29
6	191	30
7	17	---
8	17	---

PIN	LINE NO.	SSR
1	104	31
2	105	32
3	106	33
4	16	CX
5	17	---
6	17	---
7	17	---
8	17	---

STD	48	510	612	
CE	1.5Kw	2.5Kw	4Kw	

APR'D BY	CHK'D BY	DRWN BY	TITLE
99/11/30	99/11/30	99/11/30	SSR BOARD (A13) LAYOUT
T. Inoue	M Okajima	M Okajima	DRWN NO. 676 001 50201, 0



This product is subject to all the applicable Japanese Foreign Exchange and Foreign Trade Law. 本品は『外国為替及び外国貿易法』に該当しますので外国に輸出する場合には同法に基づく許可を必要とします。

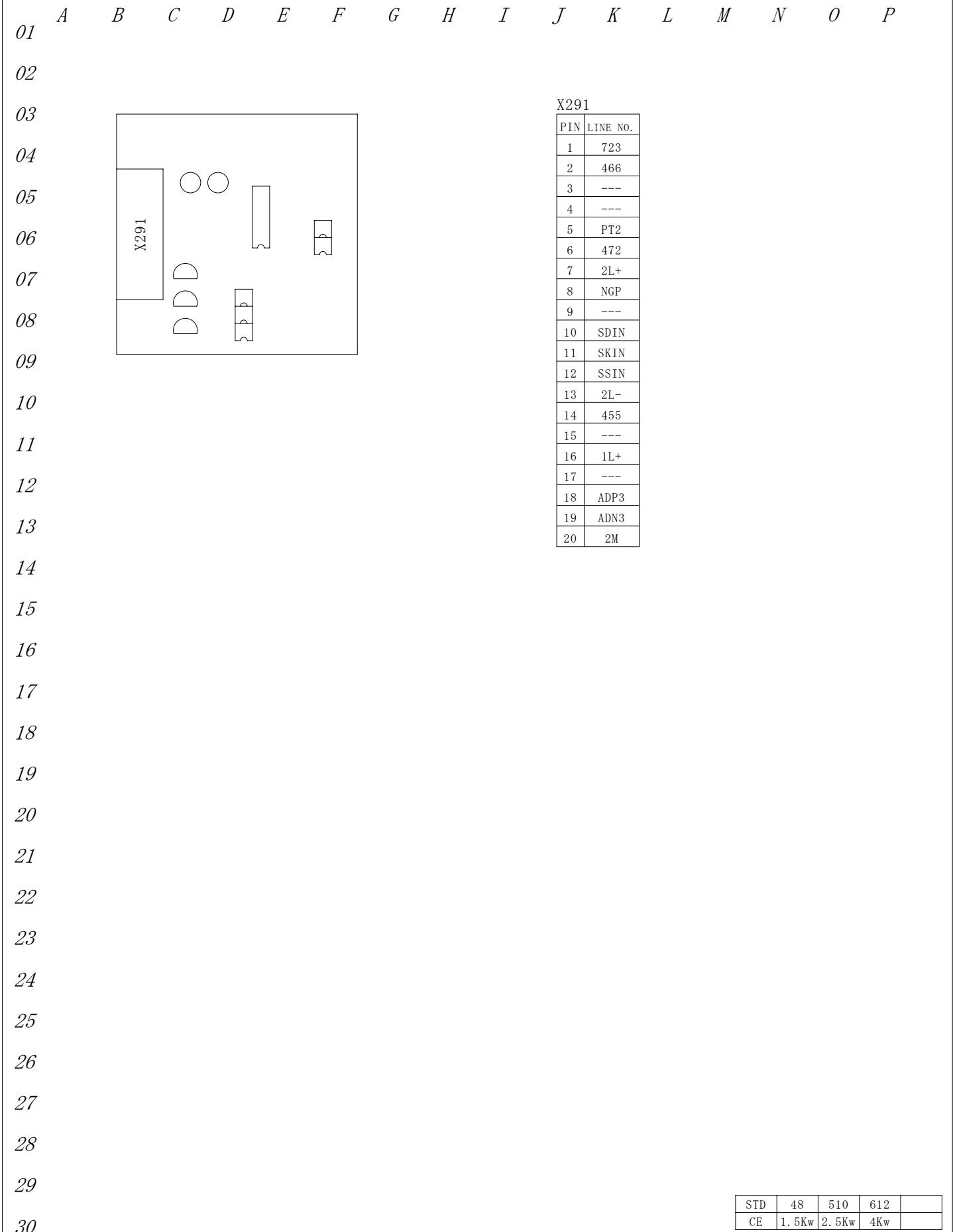

X291

PIN	LINE NO.
1	723
2	466
3	---
4	---
5	PT2
6	472
7	2L+
8	NGP
9	---
10	SDIN
11	SKIN
12	SSIN
13	2L-
14	455
15	---
16	1L+
17	---
18	ADP3
19	ADN3
20	2M

STD	48	510	612	
CE	1.5Kw	2.5Kw	4Kw	

△		 YAMAZAKI MAZAK CORPORATION	APR'D BY	CHK'D BY	DRWN BY	TITLE
△			99/11/30	99/11/30	99/11/30	OPU-100(A14) LAYOUT (OPTION)
△			T. Inoue	M Okajima	M Okajima	DRWN NO. 676 001 50250, 0
△						
△						

This product is subject to all the applicable Japanese Foreign Exchange and Foreign Trade Law.
 本品は『外国為替及び外国貿易法』に該当しますので外国に輸出する場合には同法に基づく許可を必要とします。

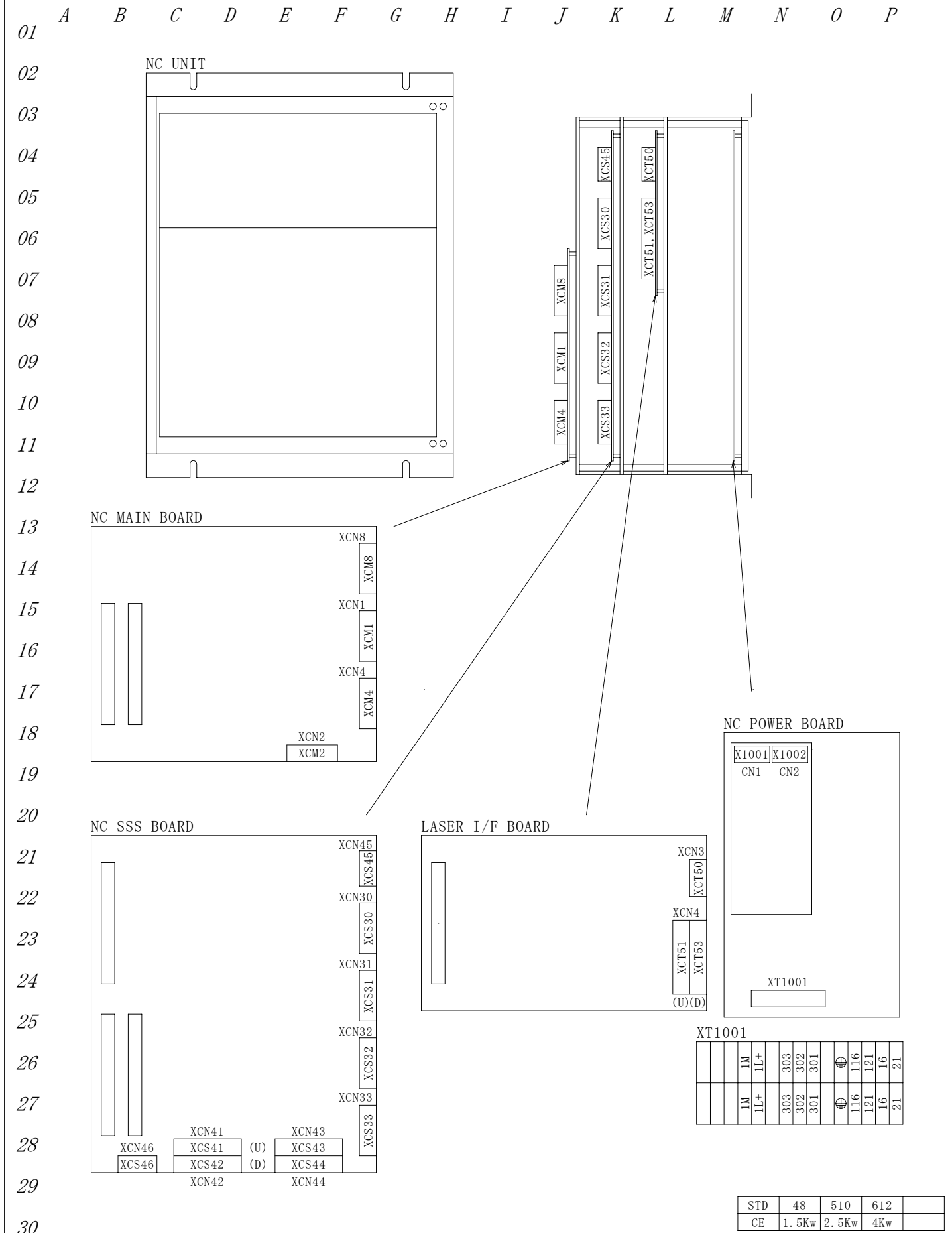

XT1001

		1M	1L+	303	302	301	⊕	116	121	16	21
		1M	1L+	303	302	301	⊕	116	121	16	21

STD	48	510	612	
CE	1.5Kw	2.5Kw	4Kw	

△		 YAMAZAKI MAZAK CORPORATION	APR' D BY	CHK' D BY	DRWN BY	TITLE
△			99/11/30	99/11/30	99/11/30	NC (A1) LAYOUT
△			T. Inoue	M Okaji ma	M Okaji ma	
△						DRWN NO.
△						676 001 50500, 0

This product is subject to all the applicable Japanese Foreign Exchange and Foreign Trade Law.
 本品は『外国為替及び外国貿易法』に該当しますので外国に輸出する場合には同法に基づく許可を必要とします。

	A	B	C	D	E	F	G	H	I	J	K	L	M	N	O	P		
01																		
02	XCS41			XCS42			XCT51											
03	PIN	LINE NO.		PIN	LINE NO.		PIN	LINE NO.				PIN	LINE NO.					
04	A1	1	---	A1	1	---	A1	1	---			A1	1	---				
05	B1	2	1M	B1	2	1M	B1	2	1M			B1	2	1M				
06	A2	3	---	A2	3	---	A2	3	---			A2	3	---				
07	B2	4	1M	B2	4	1M	B2	4	1M			B2	4	1M				
08	A3	5	---	A3	5	---	A3	5	---			A3	5	---				
09	B3	6	1M	B3	6	1M	B3	6	1M			B3	6	1M				
10	A4	7	420	A4	7	480	A4	7	480			A4	7	520				
11	B4	8	421	B4	8	481	B4	8	481			B4	8	521				
12	A5	9	422	A5	9	482	A5	9	482			A5	9	533				
13	B5	10	423	B5	10	483	B5	10	483			B5	10	530				
14	A6	11	400	A6	11	484	A6	11	484			A6	11	541				
15	B6	12	402	B6	12	485	B6	12	485			B6	12	542				
16	A7	13	404	A7	13	486	A7	13	486			A7	13	550				
17	B7	14	406	B7	14	487	B7	14	487			B7	14	551				
18	A8	15	401	A8	15	490	A8	15	490			A8	15	552				
19	B8	16	403	B8	16	491	B8	16	491			B8	16	553				
20	A9	17	405	A9	17	492	A9	17	492			A9	17	554				
21	B9	18	407	B9	18	493	B9	18	493			B9	18	523				
22	A10	19	436	A10	19	494	A10	19	494			A10	19	556				
23	B10	20	437	B10	20	495	B10	20	495			B10	20	557				
24	A11	21	430	A11	21	496	A11	21	496	A16	31	510	A11	21	555	A16	31	525
25	B11	22	417	B11	22	497	B11	22	497	B16	32	511	B11	22	547	B16	32	526
26	A12	23	431	A12	23	500	A12	23	500	A17	33	512	A12	23	540	A17	33	527
27	B12	24	416	B12	24	501	B12	24	501	B17	34	513	B12	24	535	B17	34	534
28	A13	25	435	A13	25	502	A13	25	502	A18	35	514	A13	25	543	A18	35	536
29	B13	26	440	B13	26	503	B13	26	503	B18	36	515	B13	26	522	B18	36	537
30	A14	27	441	A14	27	504	A14	27	504	A19	37	516	A14	27	546	A19	37	544
	B14	28	68	B14	28	505	B14	28	505	B19	38	517	B14	28	531	B19	38	545
	A15	29	443	A15	29	506	A15	29	506	A20	39	488	A15	29	532	A20	39	529
	B15	30	444	B15	30	507	B15	30	507	B20	40	489	B15	30	524	B20	40	538
				A21	41	461				A21	41	498				A21	41	539
				B21	42	463				B21	42	508				B21	42	548
				A22	43	464				A22	43	509				A22	43	549
				B22	44	465				B22	44	518				B22	44	558
				A23	45	466				A23	45	519				A23	45	559
				B23	46	470				B23	46	528				B23	46	562
				A24	47	471				A24	47	9109				A24	47	560
				B24	48	472				B24	48	9110				B24	48	561
				A25	49	473				A25	49	413				A25	49	434
				B25	50	454				B25	50	410				B25	50	415
				A26	51	447				A26	51	426				A26	51	412
				B26	52	467				B26	52	433				B26	52	427
				A27	53	476				A27	53	411				A27	53	425
				B27	54	462				B27	54	424				B27	54	432
				A28	55	---				A28	55	---				A28	55	---
				B28	56	1M				B28	56	1M				B28	56	1M
				A29	57	---				A29	57	---				A29	57	---
				B29	58	1M				B29	58	1M				B29	58	1M
				A30	59	---				A30	59	---				A30	59	---
				B30	60	1M				B30	60	1M				B30	60	1M

STD	48	510	612	
CE	1.5Kw	2.5Kw	4Kw	

△		 YAMAZAKI MAZAK CORPORATION	APR' D BY	CHK' D BY	DRWN BY	TITLE
△			99/11/30	99/11/30	99/11/30	NC (A1)
△			T. Inoue	M Okaji ma	M Okaji ma	CONNECTOR TABLE (2)
△						DRWN NO.
△						676 001 50520, 0

This product is subject to all the applicable Japanese Foreign Exchange and Foreign Trade Law.
 本品は『外国為替及び外国貿易法』に該当しますので外国に輸出する場合には同法に基づく許可を必要とします。

	A	B	C	D	E	F	G	H	I	J	K	L	M	N	O	P
01																
02	XCS43			XCS44			XCT53									
03	PIN LINE NO.			PIN LINE NO.			PIN LINE NO.									
04	A1	1	1L+	A1	1	1L+	A1	1	1L+							
05	B1	2	1M	B1	2	1M	B1	2	1M							
06	A2	3	1L+	A2	3	1L+	A2	3	1L+							
07	B2	4	1M	B2	4	1M	B2	4	1M							
08	A3	5	1L+	A3	5	1L+	A3	5	---							
09	B3	6	1M	B3	6	1M	B3	6	---							
10	A4	7	701	A4	7	752	A4	7	800							
11	B4	8	705	B4	8	753	B4	8	801							
12	A5	9	706	A5	9	755	A5	9	802							
13	B5	10	710	B5	10	757	B5	10	803							
14	A6	11	712	A6	11	761	A6	11	804							
15	B6	12	713	B6	12	764	B6	12	805							
16	A7	13	714	A7	13	765	A7	13	806							
17	B7	14	715	B7	14	777	B7	14	807							
18	A8	15	716	A8	15	766	A8	15	808							
19	B8	16	717	B8	16	770	B8	16	809							
20	A9	17	720	A9	17	771	A9	17	810							
21	B9	18	721	B9	18	772	B9	18	811							
22	A10	19	722	A10	19	773	A10	19	812							
23	B10	20	723	B10	20	774	B10	20	813							
24	A11	21	725	A11	21	775	A11	21	814	A16	31	824				
25	B11	22	726	B11	22	767	B11	22	815	B16	32	825				
26	A12	23	727	A12	23	776	A12	23	816	A17	33	826				
27	B12	24	737	B12	24	781	B12	24	817	B17	34	827				
28	A13	25	741	A13	25	782	A13	25	818	A18	35	828				
29	B13	26	742	B13	26	783	B13	26	819	B18	36	829				
30	A14	27	743	A14	27	786	A14	27	820	A19	37	830				
	B14	28	744	B14	28	750	B14	28	821	B19	38	831				
	A15	29	745	A15	29	751	A15	29	822	A20	39	832				
	B15	30	746	B15	30	754	B15	30	823	B20	40	833				
				A21	41	747	A21	41	758	A21	41	834				
				B21	42	736	B21	42	759	B21	42	835				
				A22	43	740	A22	43	768	A22	43	836				
				B22	44	703	B22	44	788	B22	44	837				
				A23	45	704	A23	45	789	A23	45	838				
				B23	46	707	B23	46	790	B23	46	839				
				A24	47	708	A24	47	791	A24	47	840				
				B24	48	709	B24	48	351	B24	48	841				
				A25	49	718	A25	49	---	A25	49	---				
				B25	50	719	B25	50	---	B25	50	---				
				A26	51	728	A26	51	---	A26	51	---				
				B26	52	729	B26	52	---	B26	52	---				
				A27	53	738	A27	53	---	A27	53	---				
				B27	54	739	B27	54	---	B27	54	---				
				A28	55	1L+	A28	55	1L+	A28	55	---				
				B28	56	1M	B28	56	1M	B28	56	---				
				A29	57	1L+	A29	57	---	A29	57	1L+				
				B29	58	1M	B29	58	---	B29	58	1M				
				A30	59	---	A30	59	---	A30	59	1L+				
				B30	60	---	B30	60	---	B30	60	1M				

STD	48	510	612	
CE	1.5Kw	2.5Kw	4Kw	

△		 YAMAZAKI MAZAK CORPORATION	APR' D BY	CHK' D BY	DRWN BY	TITLE
△			99/11/30	99/11/30	99/11/30	NC (A1)
△			T. Inoue	M Okaji ma	M Okaji ma	CONNECTOR TABLE (3)
△						DRWN NO.
△						676 001 50530, 0

This product is subject to all the applicable Japanese Foreign Exchange and Foreign Trade Law.
 本品は『外国為替及び外国貿易法』に該当しますので外国に輸出する場合には同法に基づく許可を必要とします。

01
02
03
04
05
06
07
08
09
10
11
12
13
14
15
16
17
18
19
20
21
22
23
24
25
26
27
28
29
30

X AXIS SERVO AMP (A3)

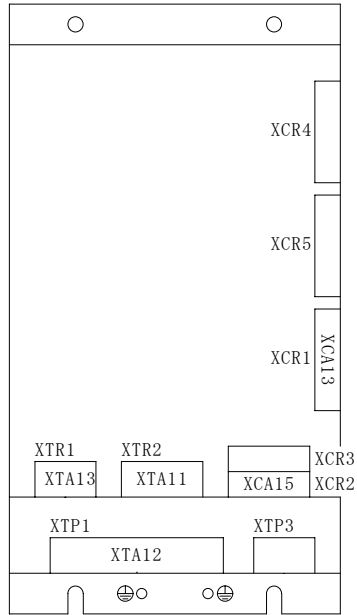

Y AXIS SERVO AMP (A4)

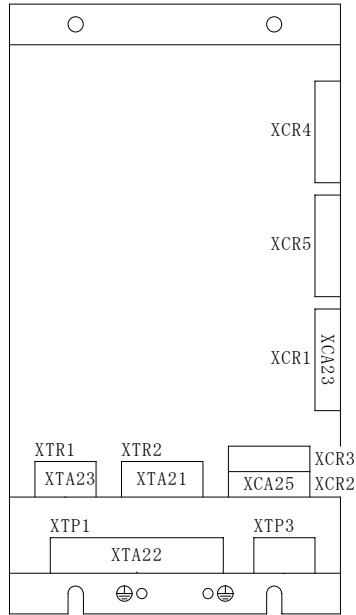

Z AXIS SERVO AMP (A5)

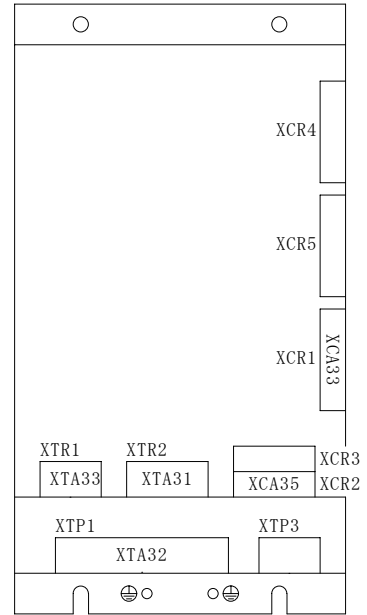

XTR2 (XTA11)

M-OH	G24	MB1	MB2	STR1	STR2	TH1	TH2
330	331	---	---	---	---	---	---

XTR2 (XTA21)

M-OH	G24	MB1	MB2	STR1	STR2	TH1	TH2
332	333	---	---	---	---	---	---

XTR2 (XTA31)

M-OH	G24	MB1	MB2	STR1	STR2	TH1	TH2
		1L+	366	---	---	---	---

JUMPER

XTP1 (XTA12)

R	S	T	U	V	W
40L1	40L2	40L3	U1	V1	W1

XTP1 (XTA22)

R	S	T	U	V	W
40L1	40L2	40L3	U2	V2	W2

XTP1 (XTA32)

R	S	T	U	V	W
40L1	40L2	40L3	U3	V3	W3

XTR1 (XTA13)

R	T
4L2	4L3



XTR1 (XTA23)

R	T
4L2	4L3



XTR1 (XTA33)

R	T
4L2	4L3



STD	48	510	612	
CE	1.5Kw	2.5Kw	4Kw	

 	 YAMAZAKI MAZAK CORPORATION	APR'D BY	CHK'D BY	DRWN BY	TITLE
		99/11/30	99/11/30	99/11/30	SERVO AMP LAYOUT
		T. Inoue	M Okajima	M Okajima	DRWN NO. 676 001 50601, 0

This product is subject to all the applicable Japanese Foreign Exchange and Foreign Trade Law.
 本品は『外国為替及び外国貿易法』に該当しますので外国に輸出する場合には同法に基づく許可を必要とします。

	A	B	C	D	E	F	G	H	I	J	K	L	M	N	O	P
01																
02		XCA13		XCA15			XCA23		XCA25			XCA33		XCA35		
03		PIN LINE NO.		PIN LINE NO.			PIN LINE NO.		PIN LINE NO.			PIN LINE NO.		PIN LINE NO.		
04		1 XIUA		1 XPA1			1 YIUA		1 YPA1			1 ZIUA		1 ZPA1		
05		2 XIVA		2 XPB1			2 YIVA		2 YPB1			2 ZIVA		2 ZPB1		
06		3 XPU		3 XPZ1			3 YPU		3 YPZ1			3 ZPU		3 ZPZ1		
07		4 *XPU		4 XC11			4 *YPU		4 YC11			4 *ZPU		4 ZC11		
08		5 XPV		5 XC21			5 YPV		5 YC21			5 ZPV		5 ZC21		
09		6 *XPV		6 XC31			6 *YPV		6 YC31			6 *ZPV		6 ZC31		
10		7 XPW		7 XVCC			7 YPW		7 YVCC			7 ZPW		7 ZVCC		
11		8 *XPW		8 XVCC			8 *YPW		8 YVCC			8 *ZPW		8 ZVCC		
12		9 XST0		9 XVCC			9 YST0		9 YVCC			9 ZST0		9 ZVCC		
13		10 XST2		10 XVCC			10 YST2		10 YVCC			10 ZST2		10 ZVCC		
14		11 *XSVON		11 XPA2			11 *YSVON		11 YPA2			11 *ZSVON		11 ZPA2		
15		12 XEMG		12 XPB2			12 YEMG		12 YPB2			12 ZEMG		12 ZPB2		
16		13 XMA1		13 XPZ2			13 YMA1		13 YPZ2			13 ZMA1		13 ZPZ2		
17		14 XMA2		14 XC12			14 YMA2		14 YC12			14 ZMA2		14 ZC12		
18		15 XMB1		15 XC22			15 YMB1		15 YC22			15 ZMB1		15 ZC22		
19		16 XMB2		16 XC32			16 YMB2		16 YC32			16 ZMB2		16 ZC32		
20		17 XMZ1		17 XSG			17 YMZ1		17 YSG			17 ZMZ1		17 ZSG		
21		18 XMZ2		18 XSG			18 YMZ2		18 YSG			18 ZMZ2		18 ZSG		
22		19 XMU1		19 XSG			19 YMU1		19 YSG			19 ZMU1		19 ZSG		
23		20 XMU2		20 XSG			20 YMU2		20 YSG			20 ZMU2		20 ZSG		
24		21 XMV1					21 YMV1					21 ZMV1				
25		22 XMV2					22 YMV2					22 ZMV2				
26		23 XMW1					23 YMW1					23 ZMW1				
27		24 XMW2					24 YMW2					24 ZMW2				
28		25 XSP1					25 YSP1					25 ZSP1				
29		26 XG15					26 YG15					26 ZG15				
30		27 XG15					27 YG15					27 ZG15				
31		28 XGND					28 YGND					28 ZGND				
32		29 XGND					29 YGND					29 ZGND				
33		30 XGND					30 YGND					30 ZGND				
34		31 XGND					31 YGND					31 ZGND				
35		32 XGND					32 YGND					32 ZGND				
36		33 XGND					33 YGND					33 ZGND				
37		34 XST1					34 YST1					34 ZST1				
38		35 XST3					35 YST3					35 ZST3				
39		36 XGND					36 YGND					36 ZGND				
40		37 XGND					37 YGND					37 ZGND				
41		38 *XMA1					38 *YMA1					38 *ZMA1				
42		39 *XMA2					39 *YMA2					39 *ZMA2				
43		40 *XMB1					40 *YMB1					40 *ZMB1				
44		41 *XMB2					41 *YMB2					41 *ZMB2				
45		42 *XMZ1					42 *YMZ1					42 *ZMZ1				
46		43 *XMZ2					43 *YMZ2					43 *ZMZ2				
47		44 *XMU1					44 *YMU1					44 *ZMU1				
48		45 *XMU2					45 *YMU2					45 *ZMU2				
49		46 *XMV1					46 *YMV1					46 *ZMV1				
50		47 *XMV2					47 *YMV2					47 *ZMV2				
51		48 *XMW1					48 *YMW1					48 *ZMW1				
52		49 *XMW2					49 *YMW2					49 *ZMW2				
53		50 XSP2					50 YSP2					50 ZSP2				

STD	48	510	612	
CE	1.5Kw	2.5Kw	4Kw	

△		 YAMAZAKI MAZAK CORPORATION	APR' D BY	CHK' D BY	DRWN BY	TITLE
△			99/11/30	99/11/30	99/11/30	SERVO AMP CONNECTOR TABLE
△			T. Inoue	M Okaji ma	M Okaji ma	DRWN NO. 676 001 50610, 0
△						
△						

This product is subject to all the applicable Japanese Foreign Exchange and Foreign Trade Law.
 本品は『外国為替及び外国貿易法』に該当しますので外国に輸出する場合には同法に基づく許可を必要とします。

01
02
03
04
05
06
07
08
09
10
11
12
13
14
15
16
17
18
19
20
21
22
23
24
25
26
27
28
29
30

MAZATROL L32B

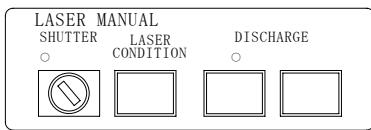
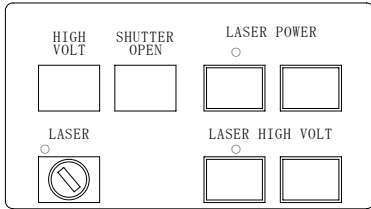

- I READY
- @BUSY
- %P. HEAD
- @P. END
- ?NC ALM
- ?MC ALM
- HOLD
- CW
- N. PULSE
- S. PULSE
- H. PULSE
- ASSIST GAS ON
- ?LASER ALM
- GAP CONTROL
- STYLUS DOWN
- X
- Y
- Z
- 4

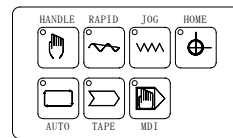
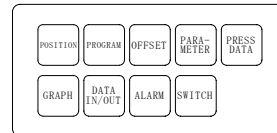
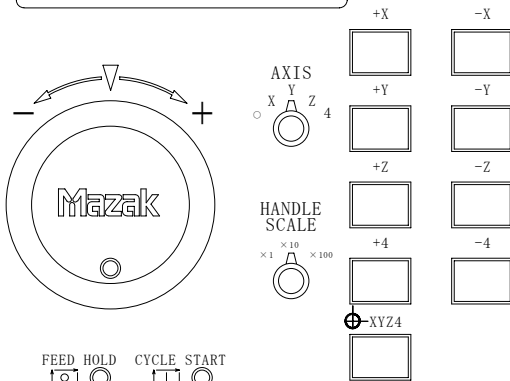
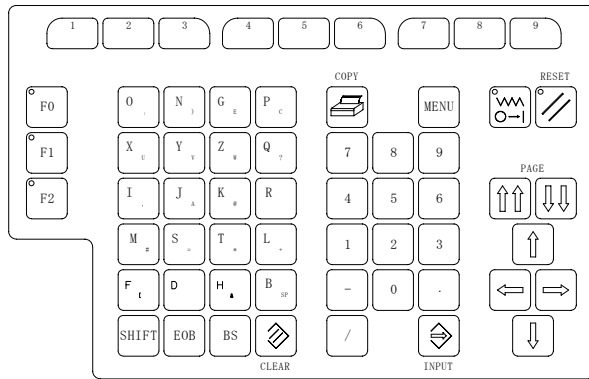
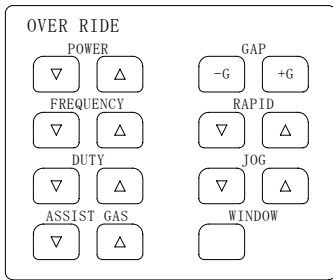

EMERGENCY STOP

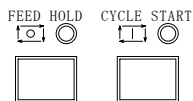
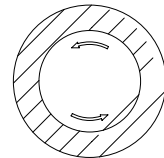

STD	48	510	612
CE	1.5Kw	2.5Kw	4Kw

	APR'D BY	CHK'D BY	DRWN BY	TITLE
	99/11/30	99/11/30	99/11/30	NC OPERATING PANEL LAYOUT(1)
	T. Inoue	M Okaji ma	M Okaji ma	DRWN NO. 676 001 50700, 0



This product is subject to all the applicable Japanese Foreign Exchange and Foreign Trade Law. 本品は『外国為替及び外国貿易法』に該当しますので外国に輸出する場合には同法に基づく許可を必要とします。

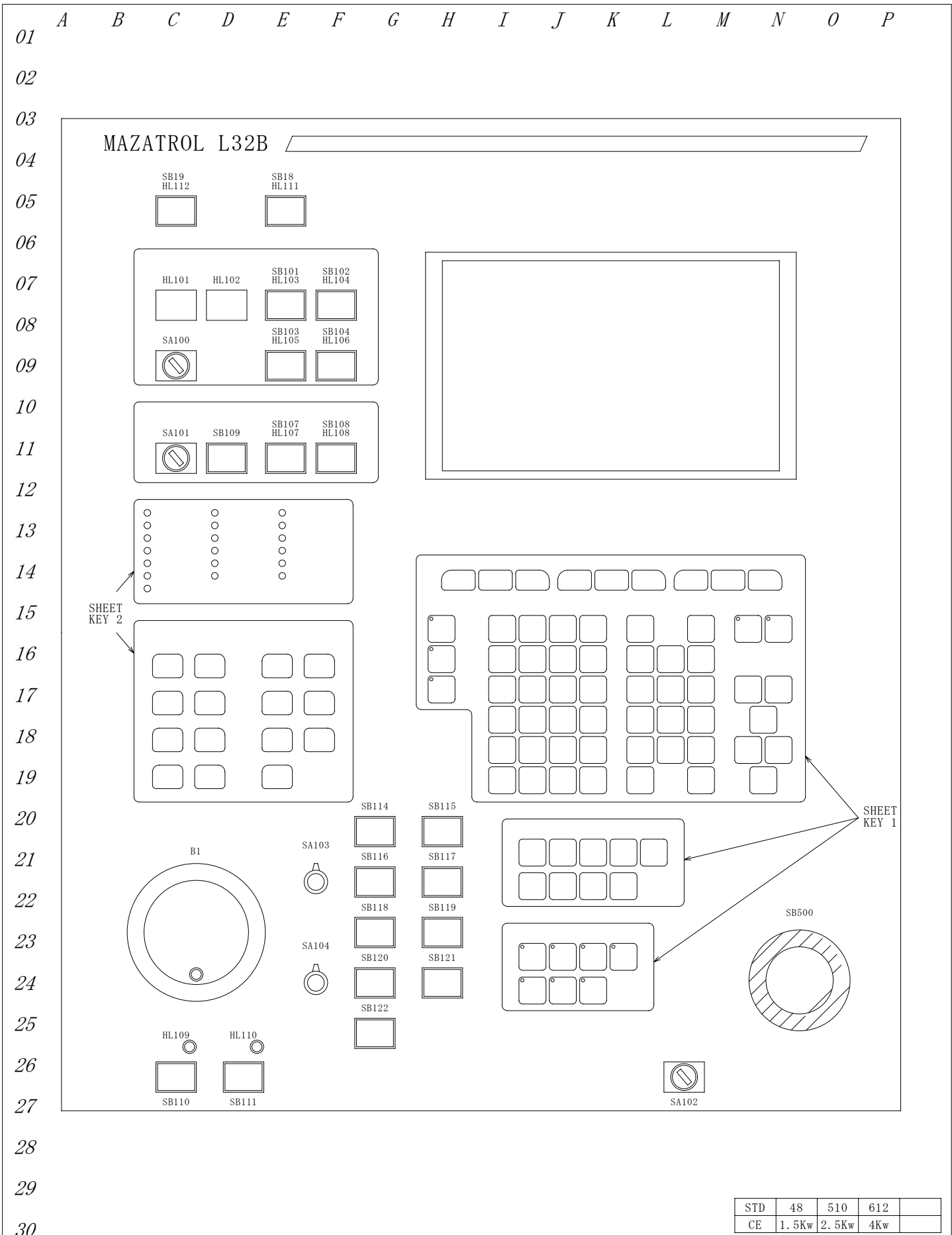

STD	48	510	612	
CE	1.5Kw	2.5Kw	4Kw	

	APR'D BY	CHK'D BY	DRWN BY	TITLE
	99/11/30	99/11/30	99/11/30	NC OPERATING PANEL LAYOUT (2)
	T. Inoue	M Okajima	M Okajima	DRWN NO. 676 001 50710, 0



This product is subject to all the applicable Japanese Foreign Exchange and Foreign Trade Law. 本品は『外国為替及び外国貿易法』に該当しますので外国に輸出する場合には同法に基づく許可を必要とします。

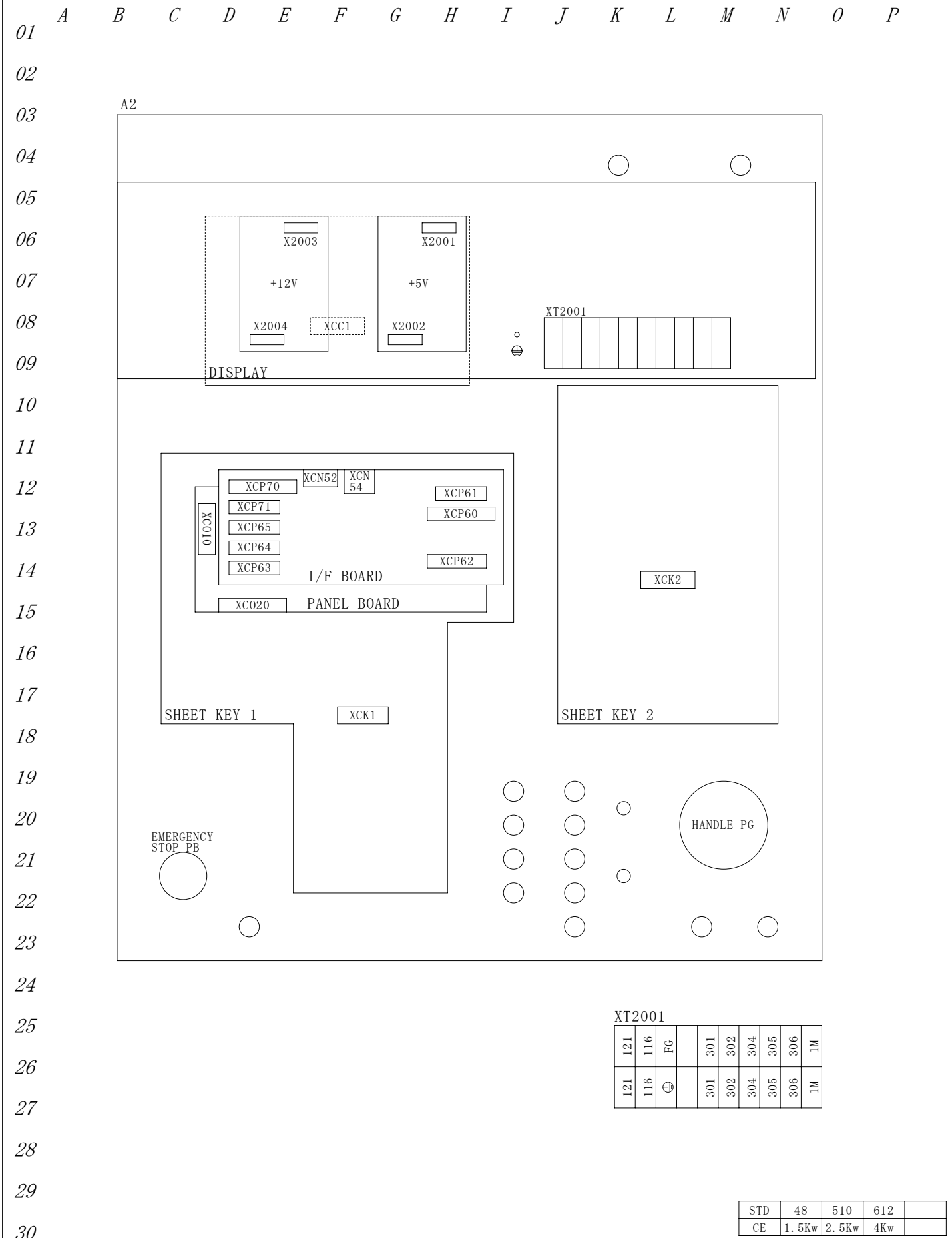

STD	48	510	612	
CE	1.5Kw	2.5Kw	4Kw	

△		 YAMAZAKI MAZAK CORPORATION	APR'D BY	CHK'D BY	DRWN BY	TITLE
△			99/11/30	99/11/30	99/11/30	NC OPERATING PANEL LAYOUT(3)
△			T. Inoue	M Okaji ma	M Okaji ma	
△						DRWN NO. 676 001 50720, 0
△						

This product is subject to all the applicable Japanese Foreign Exchange and Foreign Trade Law.
 本品は『外国為替及び外国貿易法』に該当しますので外国に輸出する場合には同法に基づく許可を必要とします。

01 A B C D E F G H I J K L M N O P

02
03
04
05
06
07
08
09
10
11
12
13
14
15
16
17
18
19
20
21
22
23
24
25
26
27
28
29
30

XCO10

PIN	LINE NO.
1	---
2	---
3	RXD
4	GND
5	TXD
6	GND
7	CTS
8	---
9	RTS
10	---
11	---
12	GND
13	MDINOG
14	MDINO
15	MDIN1G
16	MDIN1
17	MDCLK
18	MDCLKG
19	MDHD
20	MDHDG
21	MDVD
22	MDVDG
23	GND
24	GND
25	GND
26	MDIN2
27	MDIN2G
28	---

XCE1

PIN	LINE NO.
1	LDATA0
2	LDATA1
3	LDATA2
4	LDATA3
5	UDATA0
6	UDATA1
7	UDATA2
8	UDATA3
9	CP1
10	CP2
11	S
12	
13	---
14	/LDATA0
15	/LDATA1
16	/LDATA2
17	/LDATA3
18	/UDATA0
19	/UDATA1
20	/UDATA2
21	/UDATA3
22	/CP1
23	/CP2
24	/S
25	
26	---

XCP63

PIN	LINE NO.
A1	4M
B1	624
A2	625
B2	626
A3	627
B3	628
A4	629
B4	630
A5	631
B5	632
A6	633
B6	634
A7	635
B7	636
A8	637
B8	638
A9	639
B9	640
A10	641
B10	642
A11	643
B11	644
A12	645
B12	646
A13	647
B13	4M

XCP64

PIN	LINE NO.
A1	4L+
B1	916
A2	917
B2	918
A3	919
B3	920
A4	921
B4	922
A5	923
B5	924
A6	925
B6	926
A7	927
B7	928
A8	929
B8	930
A9	931
B9	932
A10	933
B10	934
A11	935
B11	936
A12	937
B12	938
A13	939
B13	4L+

X232

PIN	LINE NO.
1	FG
2	SD
3	RD
4	RS
5	CS
6	DR
7	SG
8	CD
9	---
10	---
11	---
12	---
13	---
14	---
15	---
16	---
17	---
18	---
19	---
20	ER
21	---
22	---
23	---
24	1L+
25	---

STD	48	510	612	
CE	1.5Kw	2.5Kw	4Kw	

△		 YAMAZAKI MAZAK CORPORATION	APR' D BY	CHK' D BY	DRWN BY	TITLE
△			99/11/30	99/11/30	99/11/30	NC OPERATING PANEL CONNECTOR TABLE
△			T. Inoue	M Okajima	M Okajima	
△						DRWN NO. 676 001 50730, 0
△						

This product is subject to all the applicable Japanese Foreign Exchange and Foreign Trade Law.
 本品は『外国為替及び外国貿易法』に該当しますので外国に輸出する場合には同法に基づく許可を必要とします。

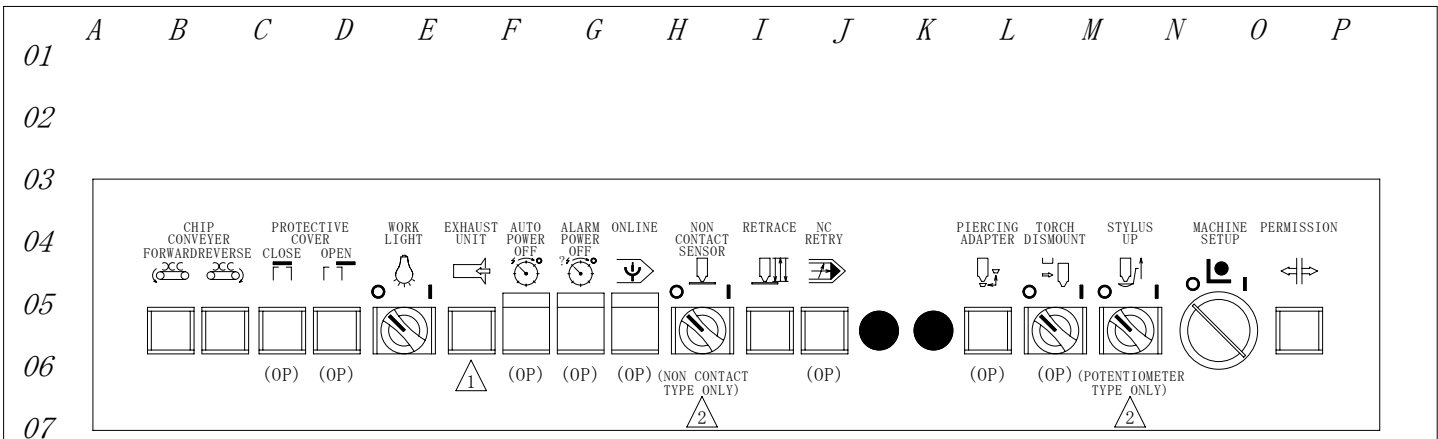

08

09 REAR CONNECTION

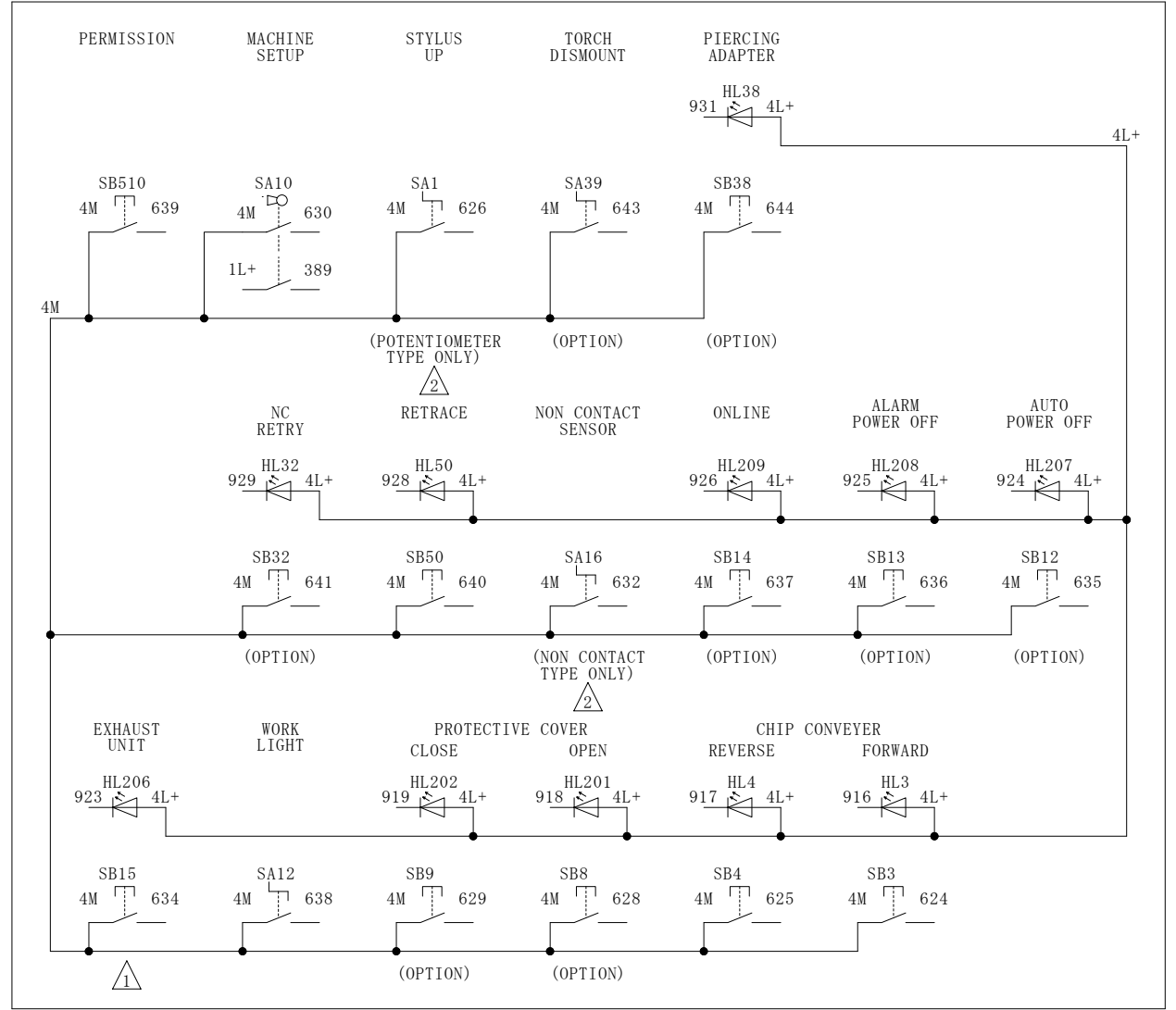

27
28
29

STD	48	510	612	
CE	1.5Kw	2.5Kw	4Kw	

△		 YAMAZAKI MAZAK CORPORATION	APR'D BY 99/11/30 T. Inoue	CHK'D BY 99/11/30 M Okajima	DRWN BY 99/11/30 M Okajima	TITLE OPERATING PANEL LAYOUT
△	Edition Aug. 07. '01 M. Okajima		DRWN NO. 676 001 50752.0			
△	Edition Mar. 27. '00 M. Okajima					
△						

This product is subject to all the applicable Japanese Foreign Exchange and Foreign Trade Law.
 本品は『外国為替及び外国貿易法』に該当しますので外国に輸出する場合には同法に基づく許可を必要とします。

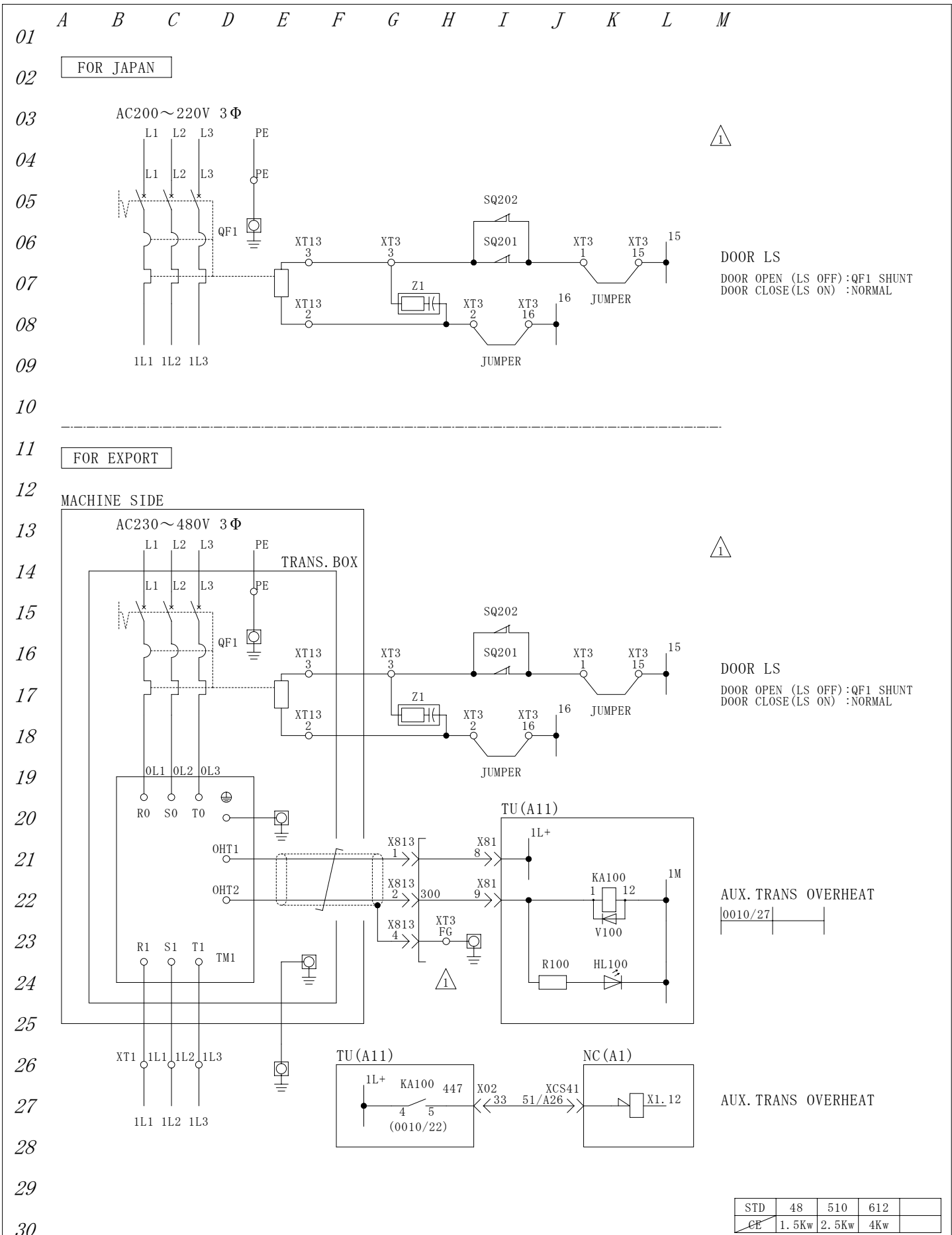

DOOR LS
 DOOR OPEN (LS OFF) : QF1 SHUNT
 DOOR CLOSE (LS ON) : NORMAL



DOOR LS
 DOOR OPEN (LS OFF) : QF1 SHUNT
 DOOR CLOSE (LS ON) : NORMAL

AUX. TRANS OVERHEAT
 0010/27

AUX. TRANS OVERHEAT

STD	48	510	612	
CE	1.5Kw	2.5Kw	4Kw	

	APR'D BY	CHK'D BY	DRWN BY	TITLE
	99/11/30	99/11/30	99/11/30	MAIN POWER(1)
	T. Inoue	M Okaji ma	M Okaji ma	DRWN NO. 676 001 40011, 0



This product is subject to all the applicable Japanese Foreign Exchange and Foreign Trade Law.
 本品は『外国為替及び外国貿易法』に該当しますので外国に輸出する場合には同法に基づく許可を必要とします。

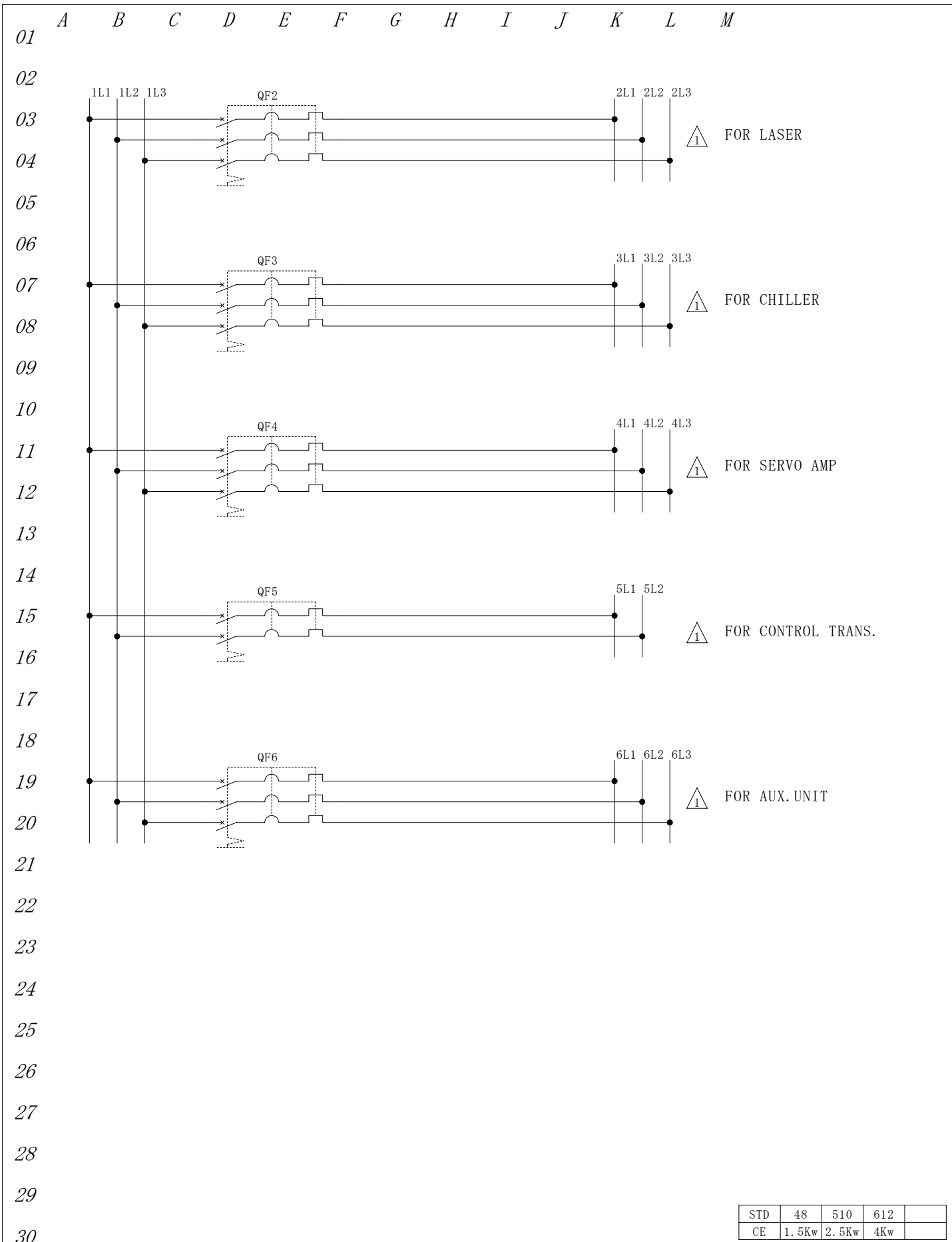

STD	48	510	612	
CE	1.5Kw	2.5Kw	4Kw	

△		 YAMAZAKI MAZAK CORPORATION	APR'D BY	CHK'D BY	DRWN BY	TITLE
△			99/11/30	99/11/30	99/11/30	MAIN POWER (2)
△			T. Inoue	M Okajima	M Okajima	
△			DRWN NO. 676 001 40031, 0			

This product is subject to all the applicable Japanese Foreign Exchange and Foreign Trade Law.
 本品は『外国為替及び外国貿易法』に該当しますので外国に輸出する場合には同法に基づく許可を必要とします。

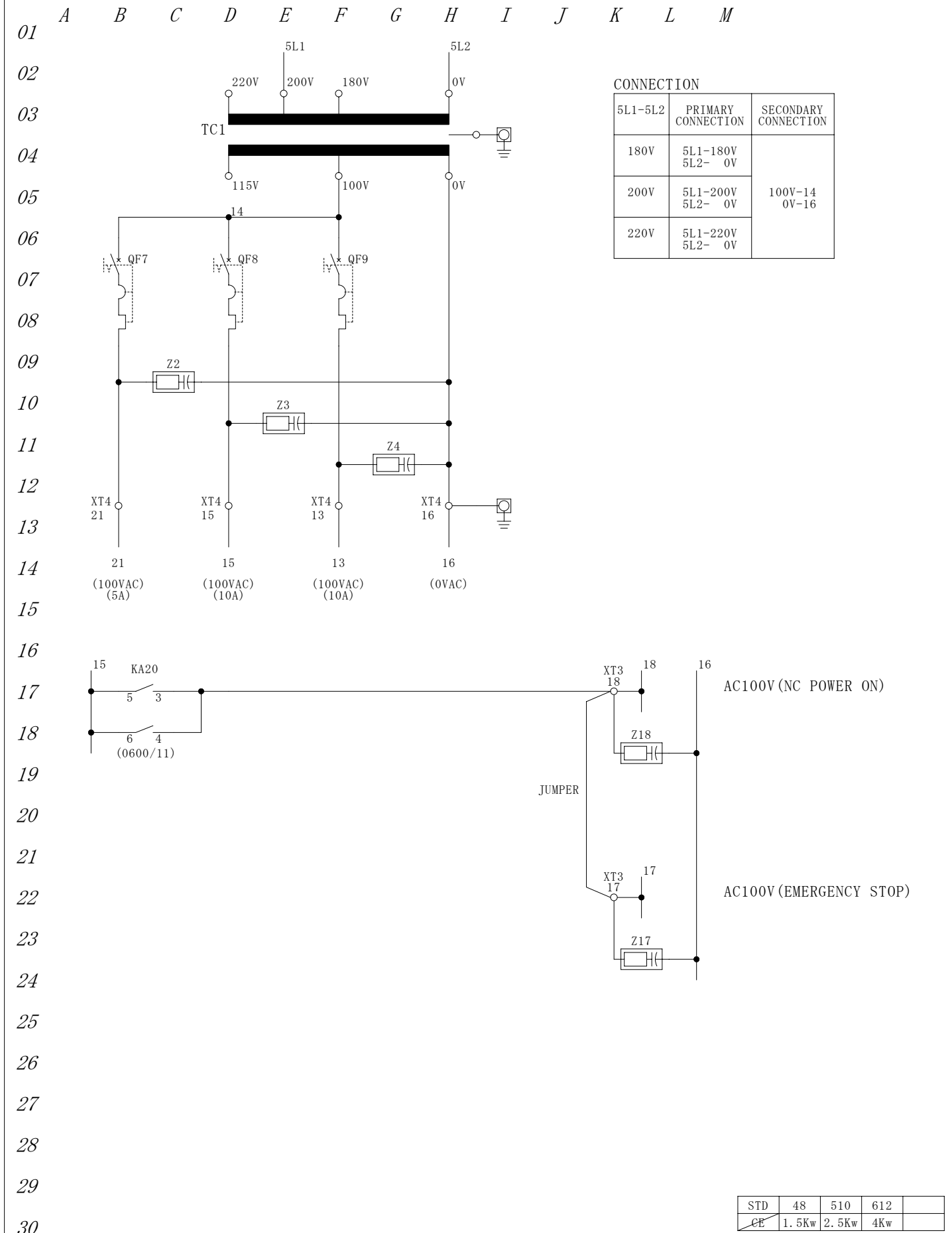

CONNECTION

5L1-5L2	PRIMARY CONNECTION	SECONDARY CONNECTION
180V	5L1-180V 5L2- 0V	100V-14 0V-16
200V	5L1-200V 5L2- 0V	
220V	5L1-220V 5L2- 0V	

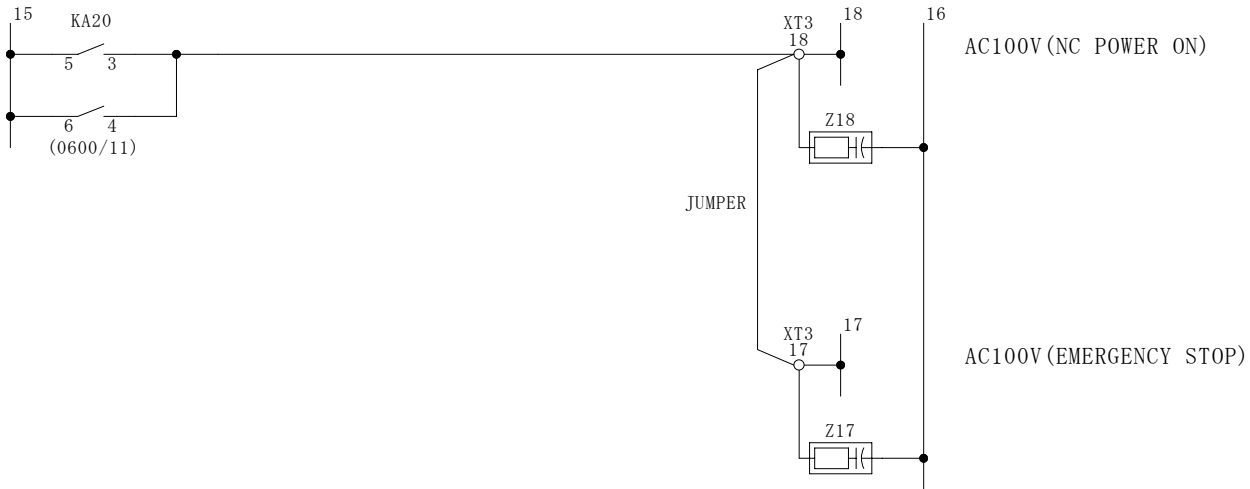

STD	48	510	612	
CE	1.5Kw	2.5Kw	4Kw	

	APR'D BY	CHK'D BY	DRWN BY	TITLE
	99/11/30	99/11/30	99/11/30	CONTROL AC100V
	T. Inoue	M Okajima	M Okajima	DRWN NO. 676 001 40050, 0

This product is subject to all the applicable Japanese Foreign Exchange and Foreign Trade Law.
 本品は『外国為替及び外国貿易法』に該当しますので外国に輸出する場合には同法に基づく許可を必要とします。

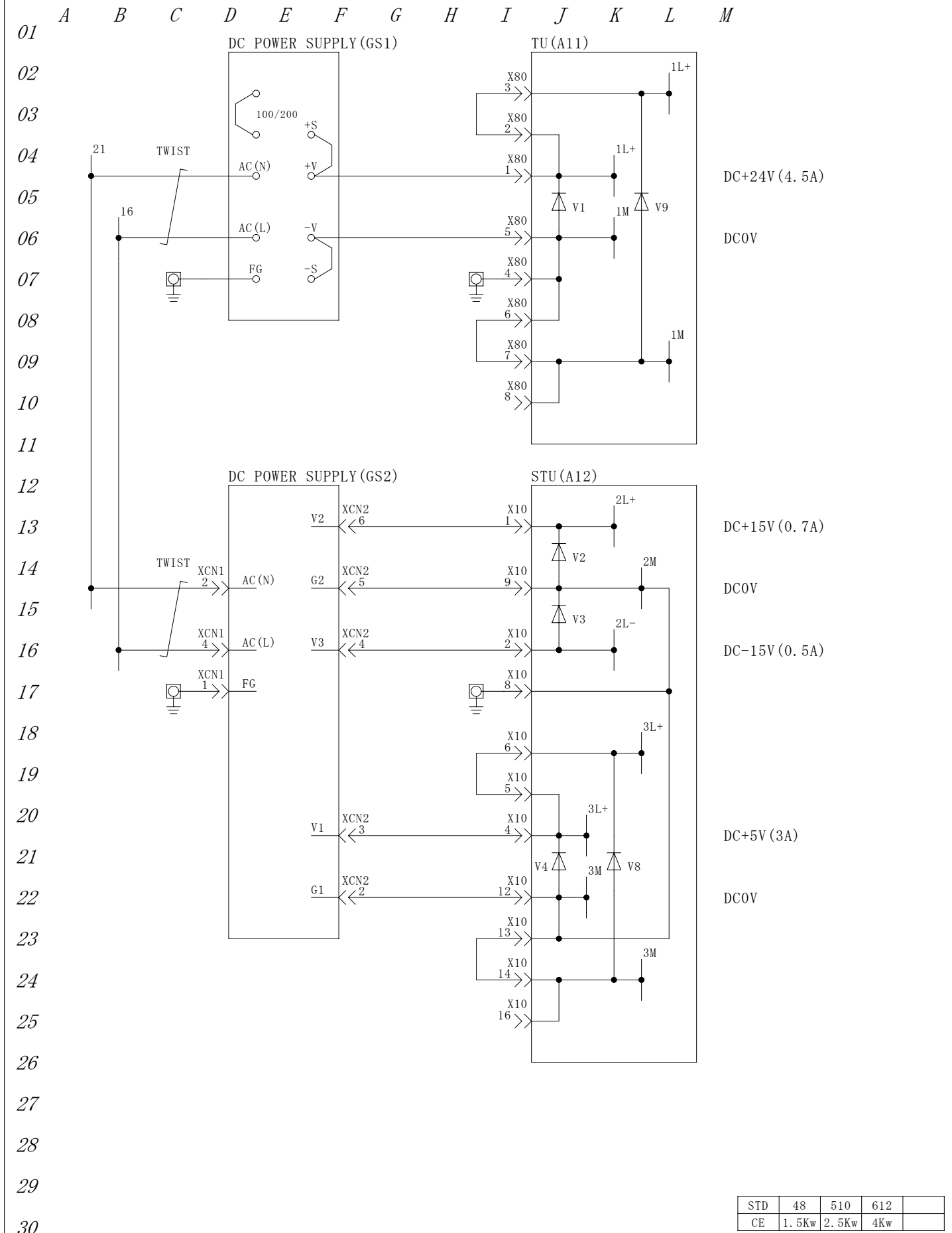

DC+24V (4.5A)

DC0V

DC+15V (0.7A)

DC0V

DC-15V (0.5A)

DC+5V (3A)

DC0V

STD	48	510	612	
CE	1.5Kw	2.5Kw	4Kw	

APR'D BY	CHK'D BY	DRWN BY	TITLE
99/11/30	99/11/30	99/11/30	DC POWER SUPPLY
T. Inoue	M Okajima	M Okajima	DRWN NO. 676 001 40070, 0



This product is subject to all the applicable Japanese Foreign Exchange and Foreign Trade Law.
 本品は『外国為替及び外国貿易法』に該当しますので外国に輸出する場合には同法に基づく許可を必要とします。

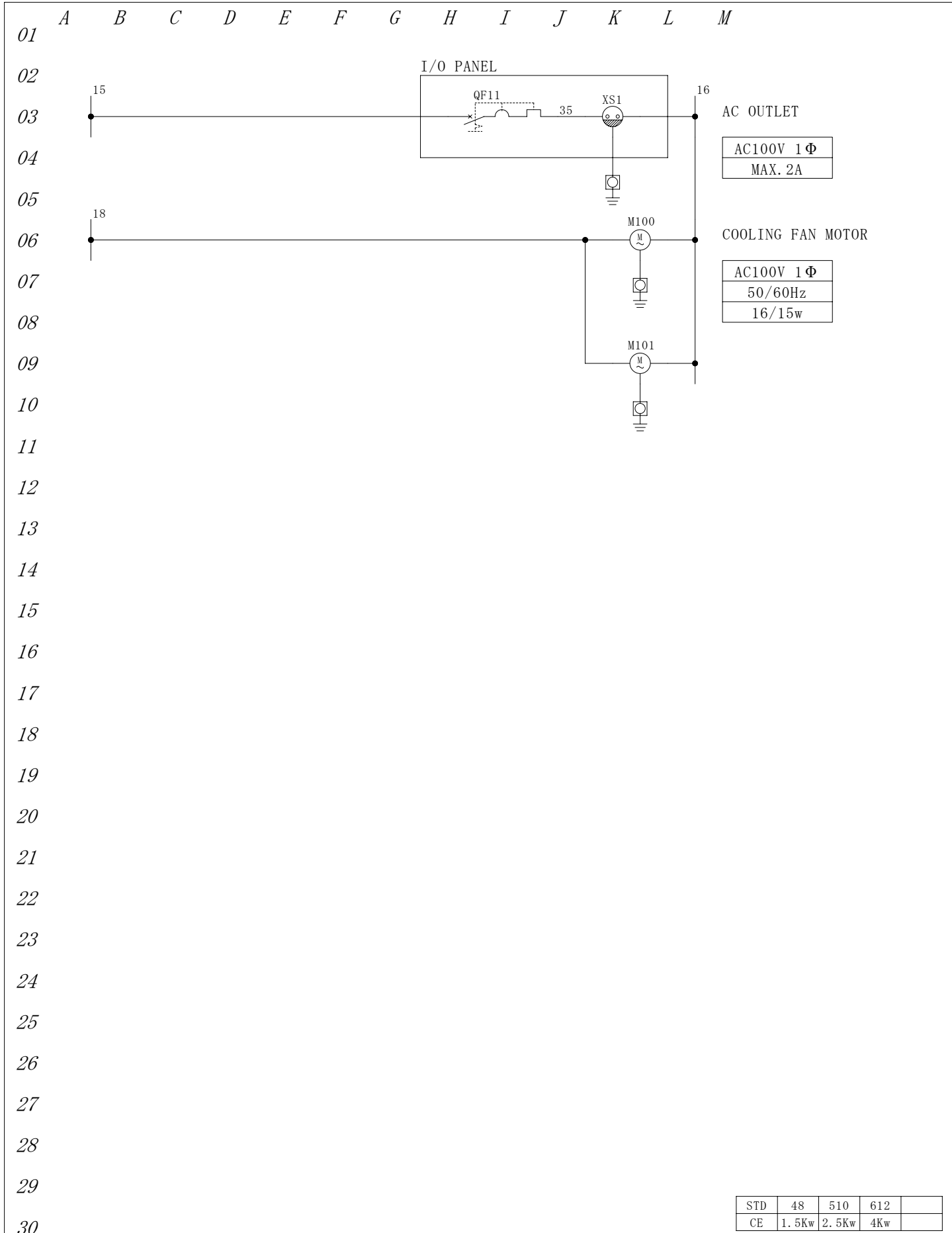

STD	48	510	612	
CE	1.5Kw	2.5Kw	4Kw	

△		 YAMAZAKI MAZAK CORPORATION	APR'D BY	CHK'D BY	DRWN BY	TITLE
△			99/11/30	99/11/30	99/11/30	AC100V CIRCUIT
△			T. Inoue	M Okajima	M Okajima	
△						DRWN NO.
△						676 001 40100, 0

This product is subject to all the applicable Japanese Foreign Exchange and Foreign Trade Law.
 本品は『外国為替及び外国貿易法』に該当しますので外国に輸出する場合には同法に基づく許可を必要とします。

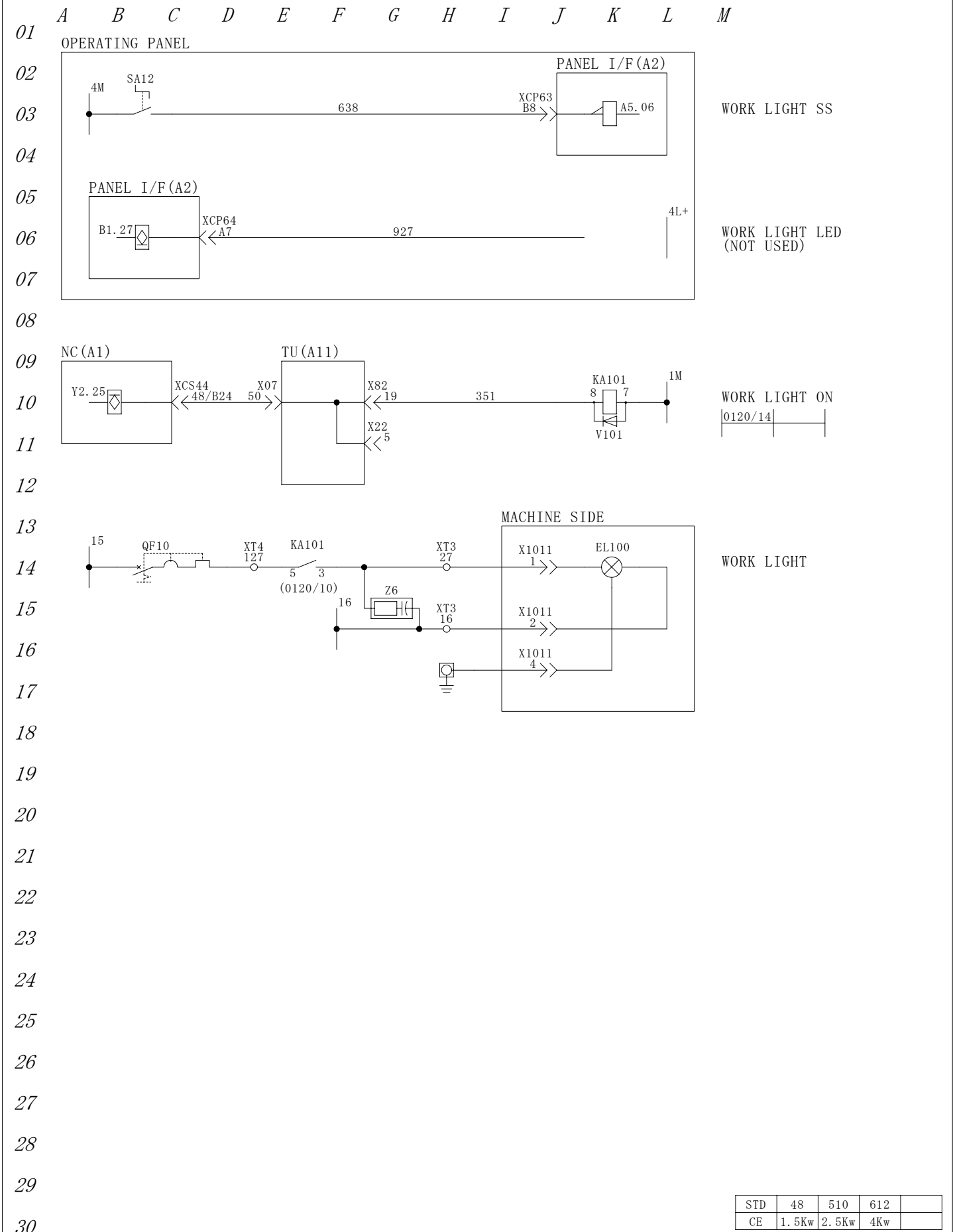

STD	48	510	612	
CE	1.5Kw	2.5Kw	4Kw	

APR' D BY 99/11/30 T. Inoue	CHK' D BY 99/11/30 M Okajima	DRWN BY 99/11/30 M Okajima	TITLE WORK LIGHT DRWN NO. 676 001 40120, 0
-----------------------------------	------------------------------------	----------------------------------	--

This product is subject to all the applicable Japanese Foreign Exchange and Foreign Trade Law.
 本品は『外国為替及び外国貿易法』に該当しますので外国に輸出する場合には同法に基づく許可を必要とします。

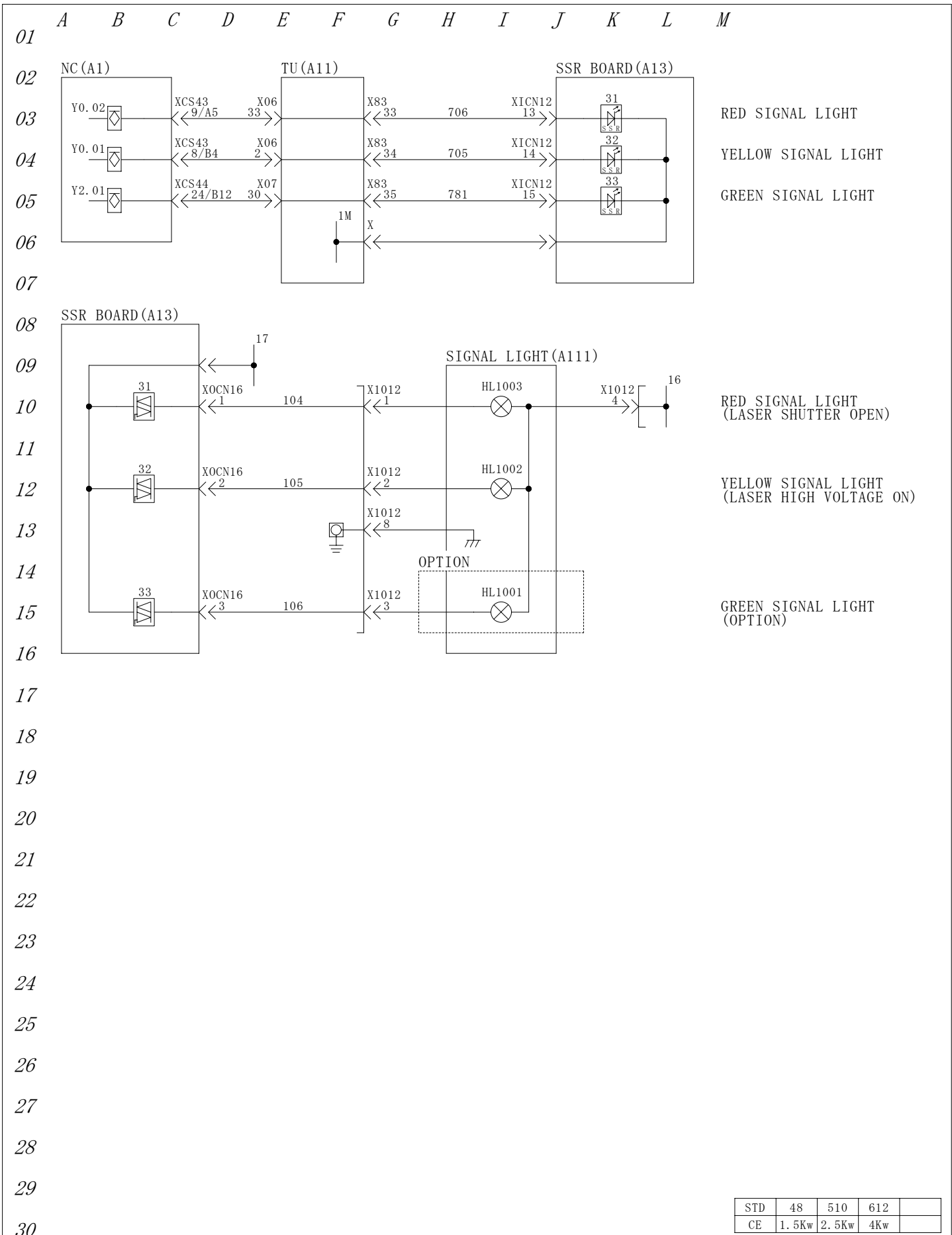

STD	48	510	612	
CE	1.5Kw	2.5Kw	4Kw	

APR'D BY	CHK'D BY	DRWN BY	TITLE
99/11/30	99/11/30	99/11/30	SIGNAL LIGHT
T. Inoue	M Okajima	M Okajima	DRWN NO. 676 001 40130, 0



This product is subject to all the applicable Japanese Foreign Exchange and Foreign Trade Law.
 本品は『外国為替及び外国貿易法』に該当しますので外国に輸出する場合には同法に基づく許可を必要とします。

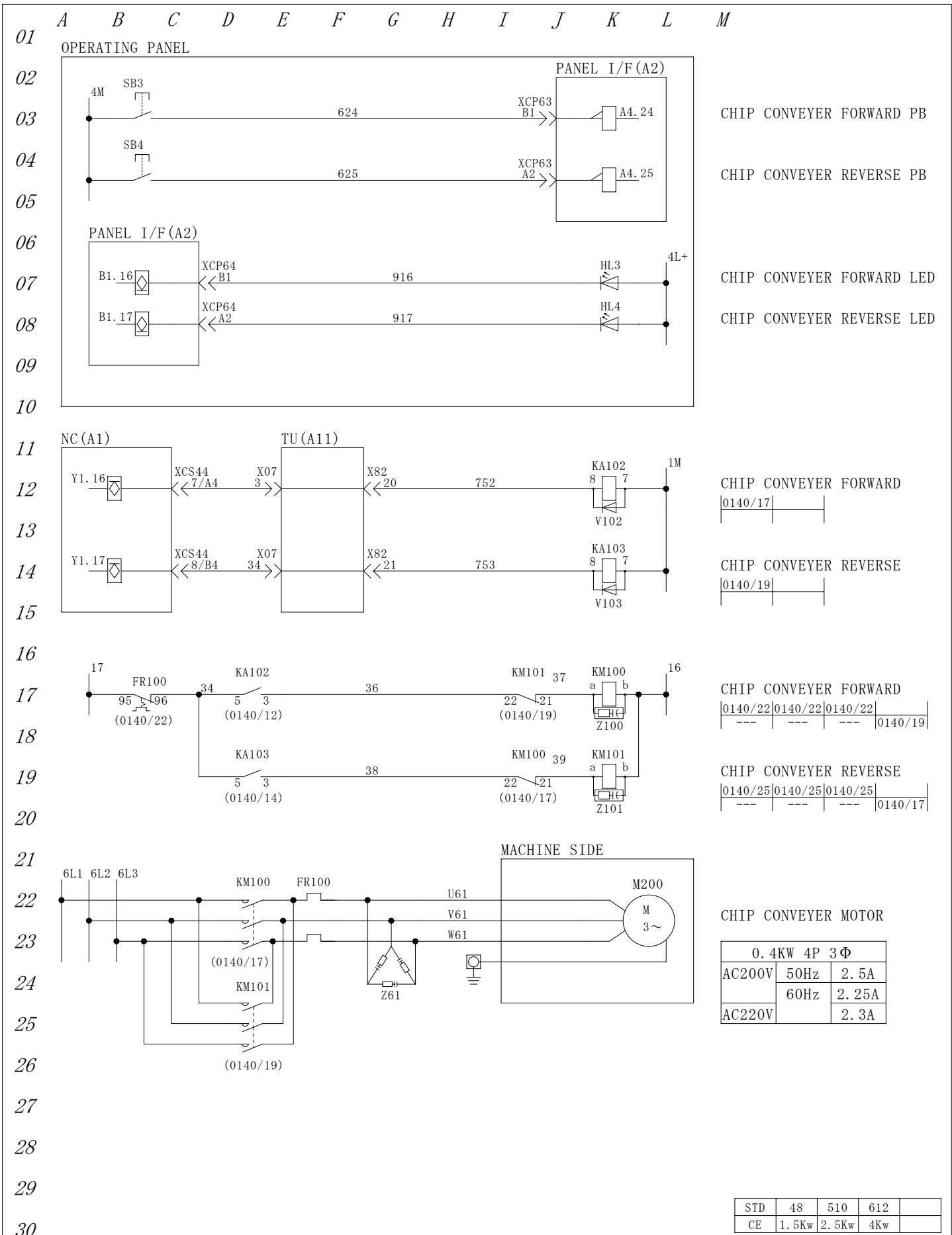

CHIP CONVEYER FORWARD PB

CHIP CONVEYER REVERSE PB

CHIP CONVEYER FORWARD LED

CHIP CONVEYER REVERSE LED

CHIP CONVEYER FORWARD

CHIP CONVEYER REVERSE

CHIP CONVEYER FORWARD

CHIP CONVEYER REVERSE

CHIP CONVEYER MOTOR

0.4KW 4P 3Φ		
AC200V	50Hz	2.5A
	60Hz	2.25A
AC220V		2.3A

STD	48	510	612	
CE	1.5Kw	2.5Kw	4Kw	

APR'D BY	CHK'D BY	DRWN BY	TITLE
99/11/30	99/11/30	99/11/30	CHIP CONVEYER
T. Inoue	M Okajima	M Okajima	DRWN NO. 676 001 40140, 0



This product is subject to all the applicable Japanese Foreign Exchange and Foreign Trade Law. 本品は『外国為替及び外国貿易法』に該当しますので外国に輸出する場合には同法に基づく許可を必要とします。

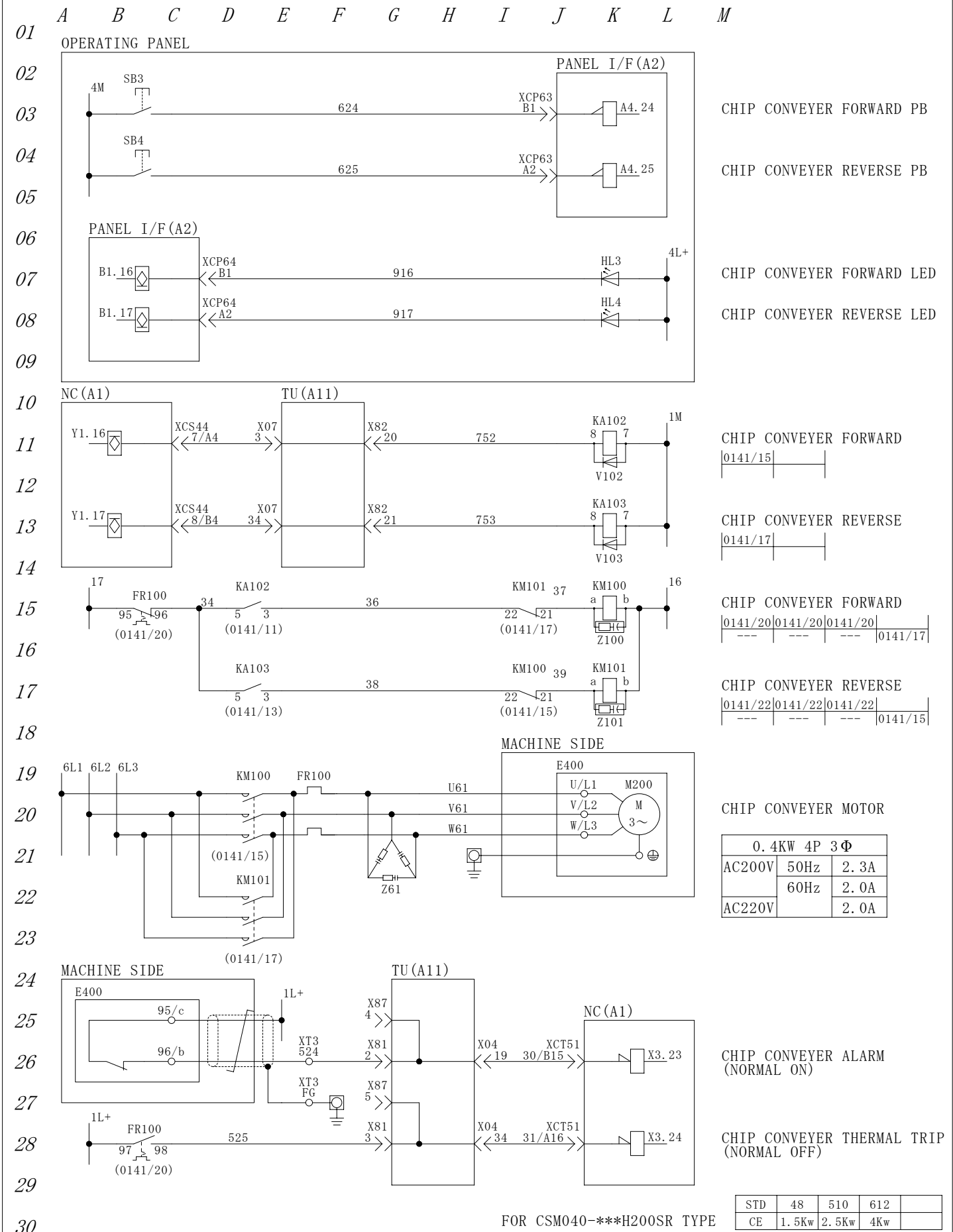

0.4KW 4P 3Φ		
AC200V	50Hz	2.3A
	60Hz	2.0A
AC220V		2.0A

STD	48	510	612	
CE	1.5Kw	2.5Kw	4Kw	

FOR CSM040-***H200SR TYPE

APR'D BY	CHK'D BY	DRWN BY	TITLE
03/05/06	03/05/06	03/05/06	CHIP CONVEYER
T. Inoue	M Okaji ma	M Okaji ma	DRWN NO. 676 001 40140, 1



This product is subject to all the applicable Japanese Foreign Exchange and Foreign Trade Law. 本品は『外国為替及び外国貿易法』に該当しますので外国に輸出する場合には同法に基づく許可を必要とします。

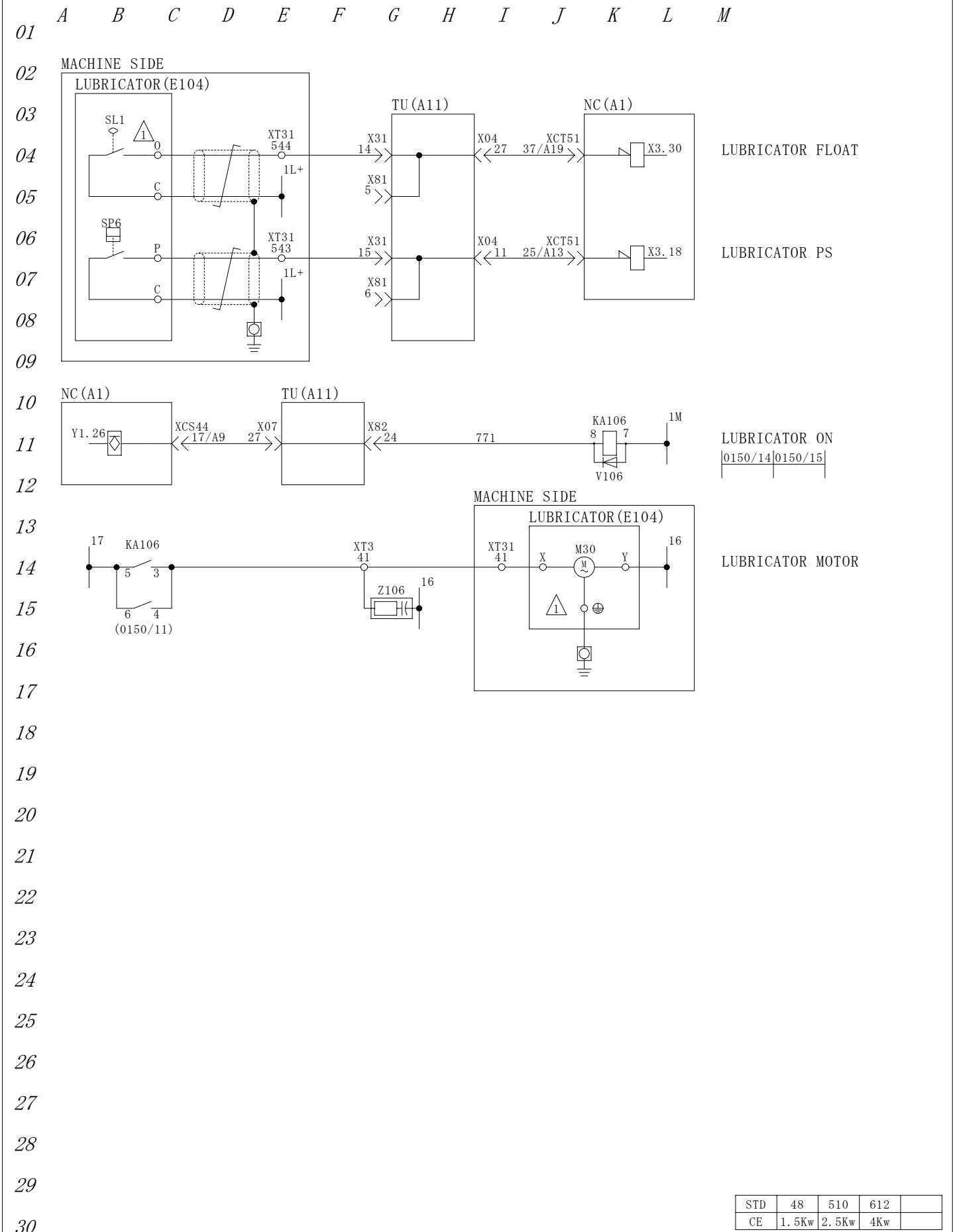

STD	48	510	612	
CE	1.5Kw	2.5Kw	4Kw	

	APR'D BY	CHK'D BY	DRWN BY	TITLE
	99/11/30	99/11/30	99/11/30	LUBRICATOR
	T. Inoue	M Okajima	M Okajima	DRWN NO. 676 001 40151, 0



This product is subject to all the applicable Japanese Foreign Exchange and Foreign Trade Law.
 本品は『外国為替及び外国貿易法』に該当しますので外国に輸出する場合には同法に基づく許可を必要とします。

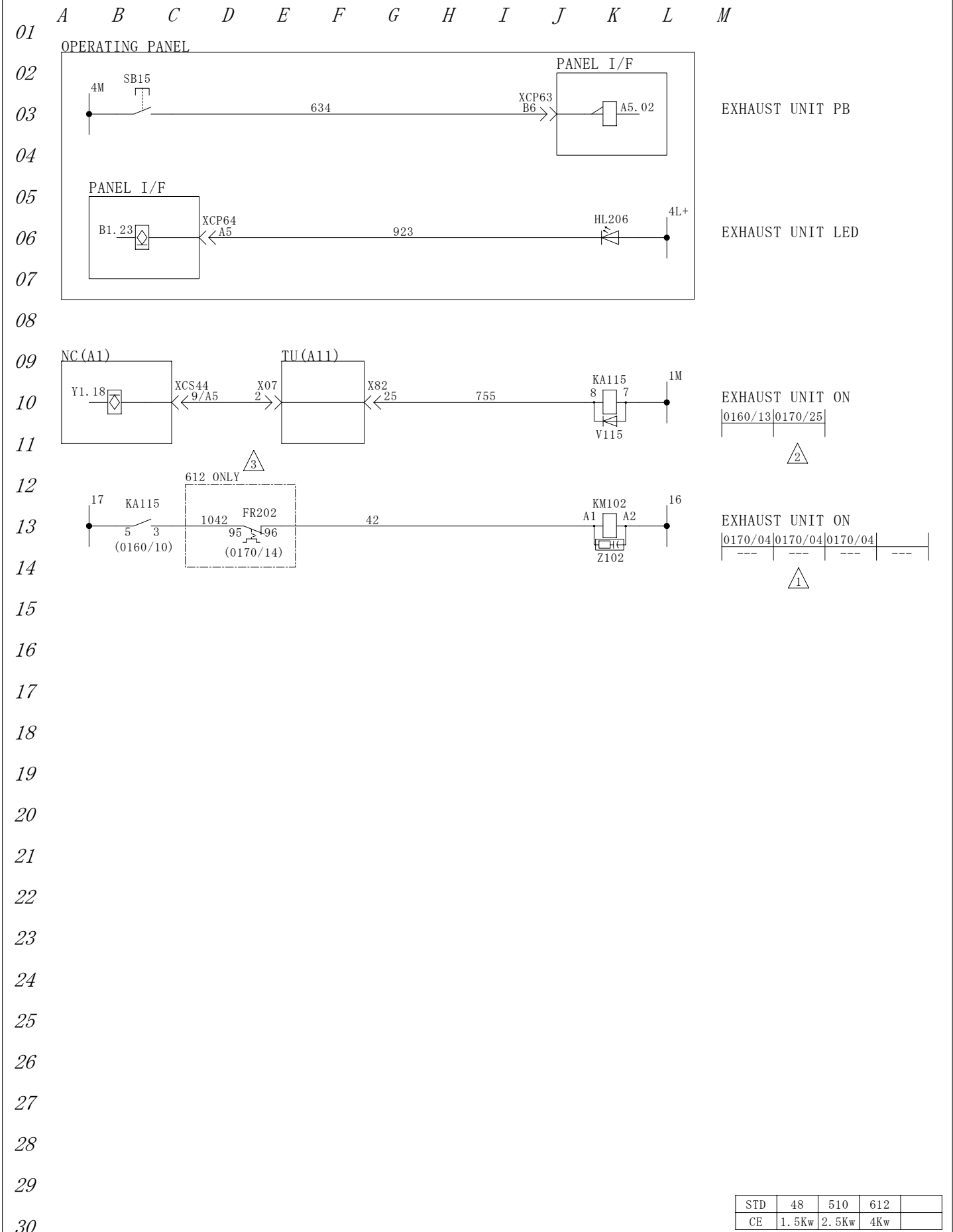

STD	48	510	612	
CE	1.5Kw	2.5Kw	4Kw	

△		 YAMAZAKI MAZAK CORPORATION	APR'D BY	CHK'D BY	DRWN BY	TITLE
△			99/11/30	99/11/30	99/11/30	EXHAUST UNIT
△	Edition Jul.08.'05 M.Okajima		T. Inoue	M Okajima	M Okajima	DRWN NO. 676 001 40163, 0
△	Edition Mar.28.'05 M.Okajima					
△	Edition May.11.'01 M.Okajima					

This product is subject to all the applicable Japanese Foreign Exchange and Foreign Trade Law.
 本品は『外国為替及び外国貿易法』に該当しますので外国に輸出する場合には同法に基づく許可を必要とします。

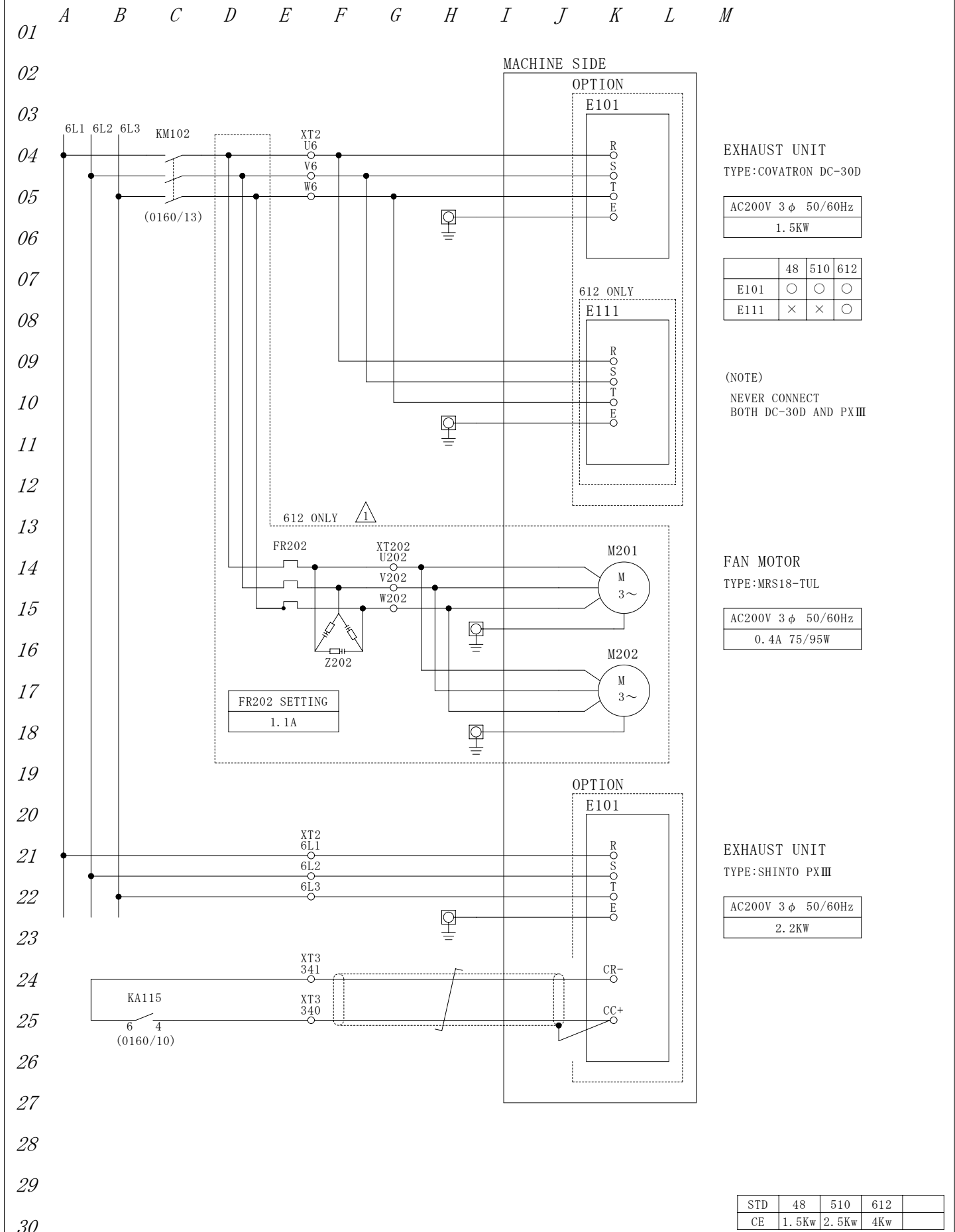

△		 YAMAZAKI MAZAK CORPORATION	APR'D BY	CHK'D BY	DRWN BY	TITLE
△			01/05/11	01/05/11	01/05/11	EXHAUST UNIT (2)
△			T. Inoue	M Okajima	M Okajima	DRWN NO. 676 001 40171, 0
△	Edition Mar. 28. '05 M. Okajima					

This product is subject to all the applicable Japanese Foreign Exchange and Foreign Trade Law.
 本品は『外国為替及び外国貿易法』に該当しますので外国に輸出する場合には同法に基づく許可を必要とします。

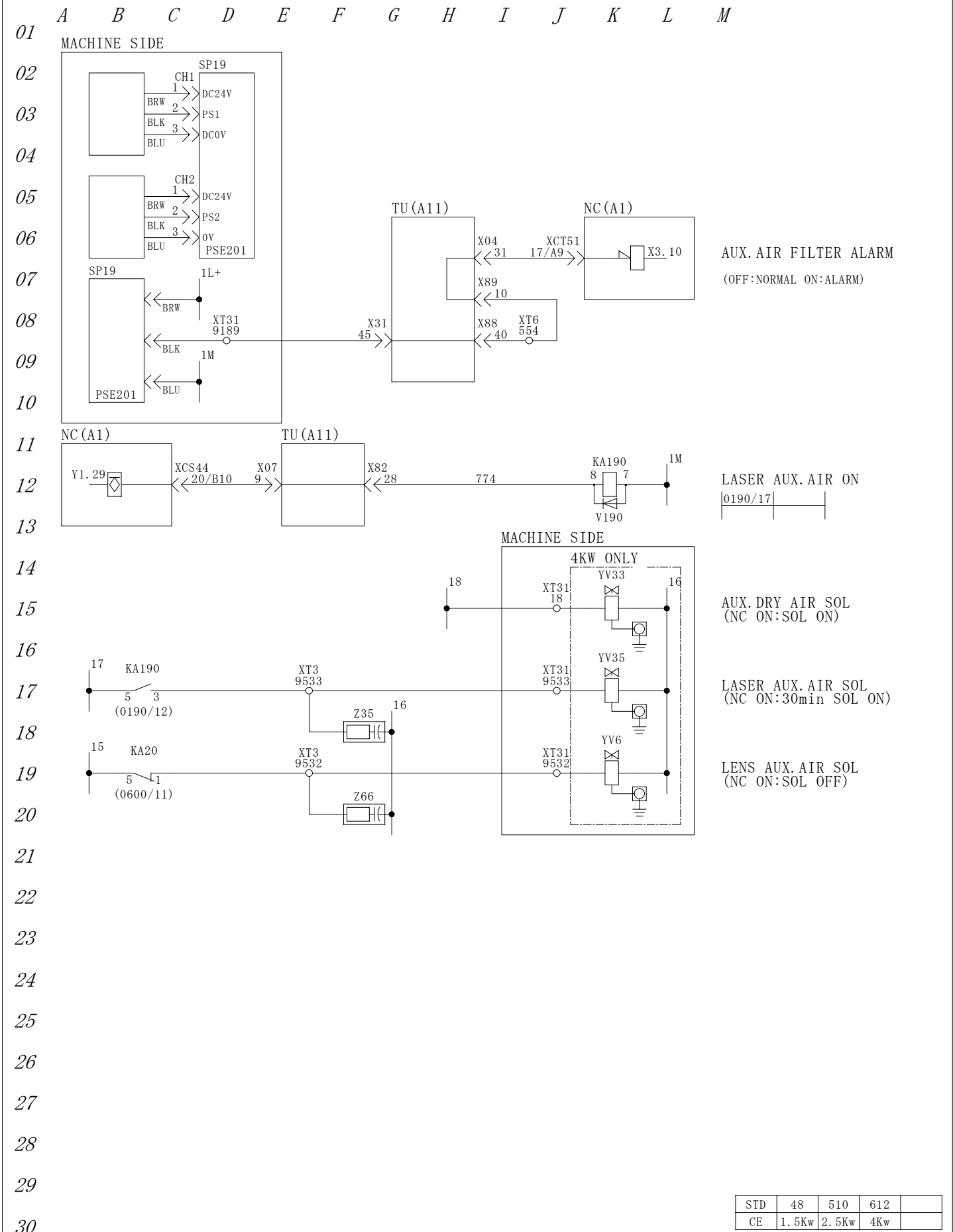

STD	48	510	612	
CE	1.5Kw	2.5Kw	4Kw	

△		 YAMAZAKI MAZAK CORPORATION	APR'D BY	CHK'D BY	DRWN BY	TITLE
△			03/10/10	03/10/10	03/10/10	AUX. DRY AIR
△			T. Inoue	M Okajima	M Okajima	
△						DRWN NO. 676 001 40190, 0
△						

This product is subject to all the applicable Japanese Foreign Exchange and Foreign Trade Law.
 本品は『外国為替及び外国貿易法』に該当しますので外国に輸出する場合には同法に基づく許可を必要とします。

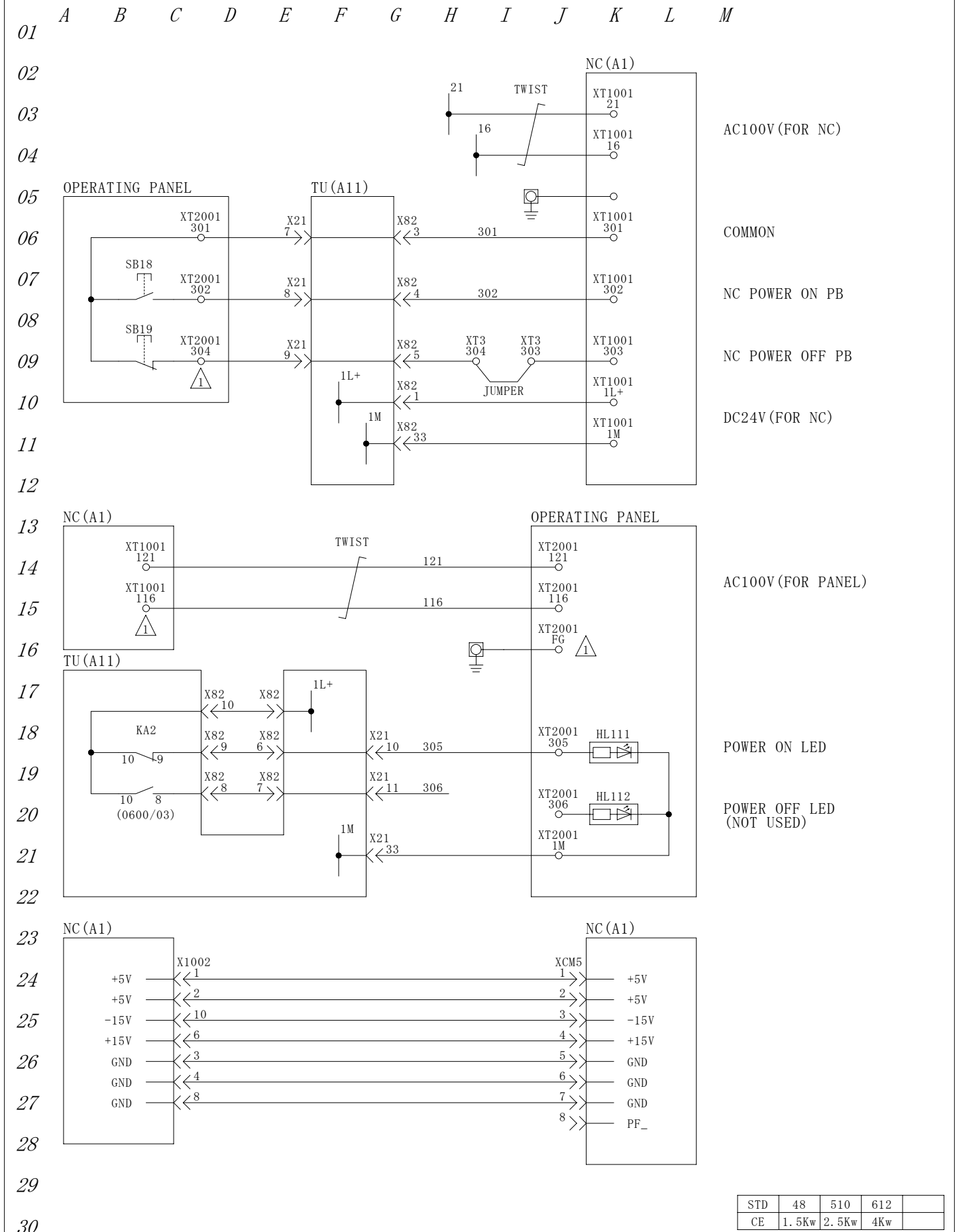

STD	48	510	612	
CE	1.5Kw	2.5Kw	4Kw	

		APR'D BY	CHK'D BY	DRWN BY	TITLE
		99/11/30	99/11/30	99/11/30	NC POWER UNIT
Edition Jul.01.'00 M.Okajima		T. Inoue	M Okaji ma	M Okaji ma	DRWN NO. 676 001 40201, 0

This product is subject to all the applicable Japanese Foreign Exchange and Foreign Trade Law.
 本品は『外国為替及び外国貿易法』に該当しますので外国に輸出する場合には同法に基づく許可を必要とします。

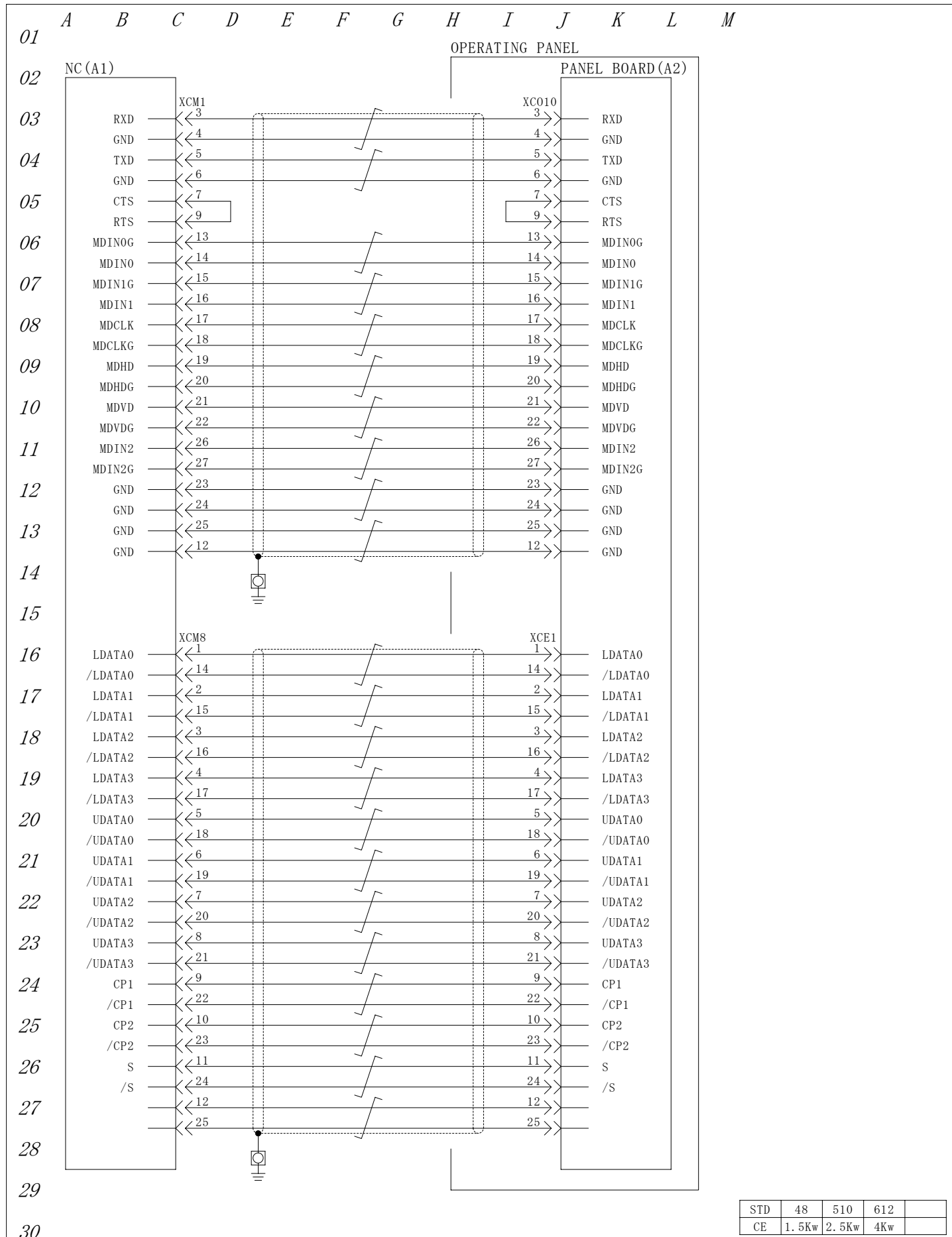

STD	48	510	612	
CE	1.5Kw	2.5Kw	4Kw	

△		 YAMAZAKI MAZAK CORPORATION	APR'D BY	CHK'D BY	DRWN BY	TITLE
△			99/11/30	99/11/30	99/11/30	NC OPERATING PANEL INTERFACE
△			T. Inoue	M Okaji ma	M Okaji ma	DRWN NO. 676 001 40210, 0
△						
△						

This product is subject to all the applicable Japanese Foreign Exchange and Foreign Trade Law.
 本品は『外国為替及び外国貿易法』に該当しますので外国に輸出する場合には同法に基づく許可を必要とします。

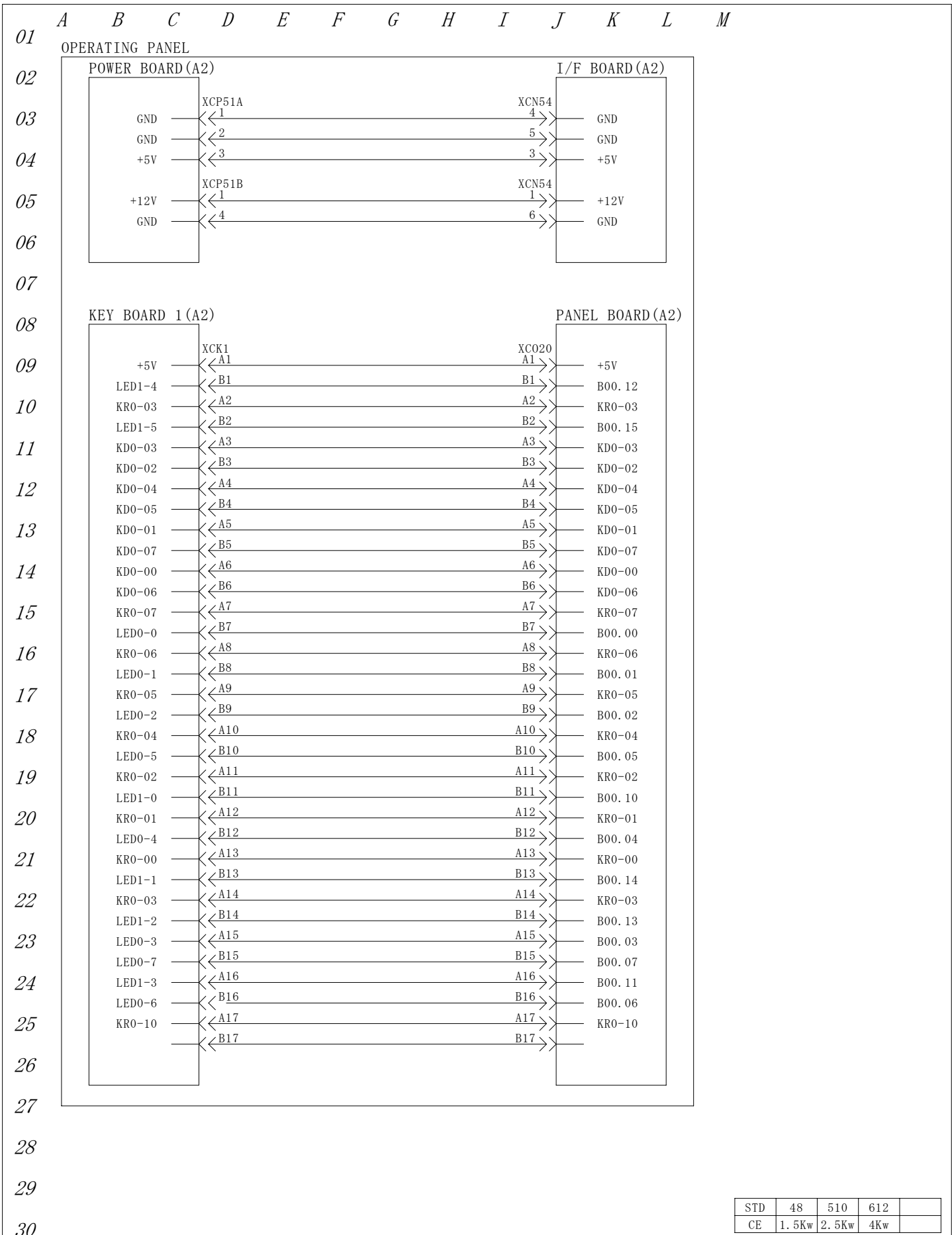

STD	48	510	612	
CE	1.5Kw	2.5Kw	4Kw	

△		 YAMAZAKI MAZAK CORPORATION	APR' D BY	CHK' D BY	DRWN BY	TITLE
△			99/11/30	99/11/30	99/11/30	NC OPERATING PANEL CONNECTION(1)
△			T. Inoue	M Okaji ma	M Okaji ma	DRWN NO. 676 001 40220, 0
△						
△						

This product is subject to all the applicable Japanese Foreign Exchange and Foreign Trade Law.
 本品は『外国為替及び外国貿易法』に該当しますので外国に輸出する場合には同法に基づく許可を必要とします。

01
02
03
04
05
06
07
08
09
10
11
12
13
14
15
16
17
18
19
20
21
22
23
24
25
26
27
28
29
30

OPERATING PANEL

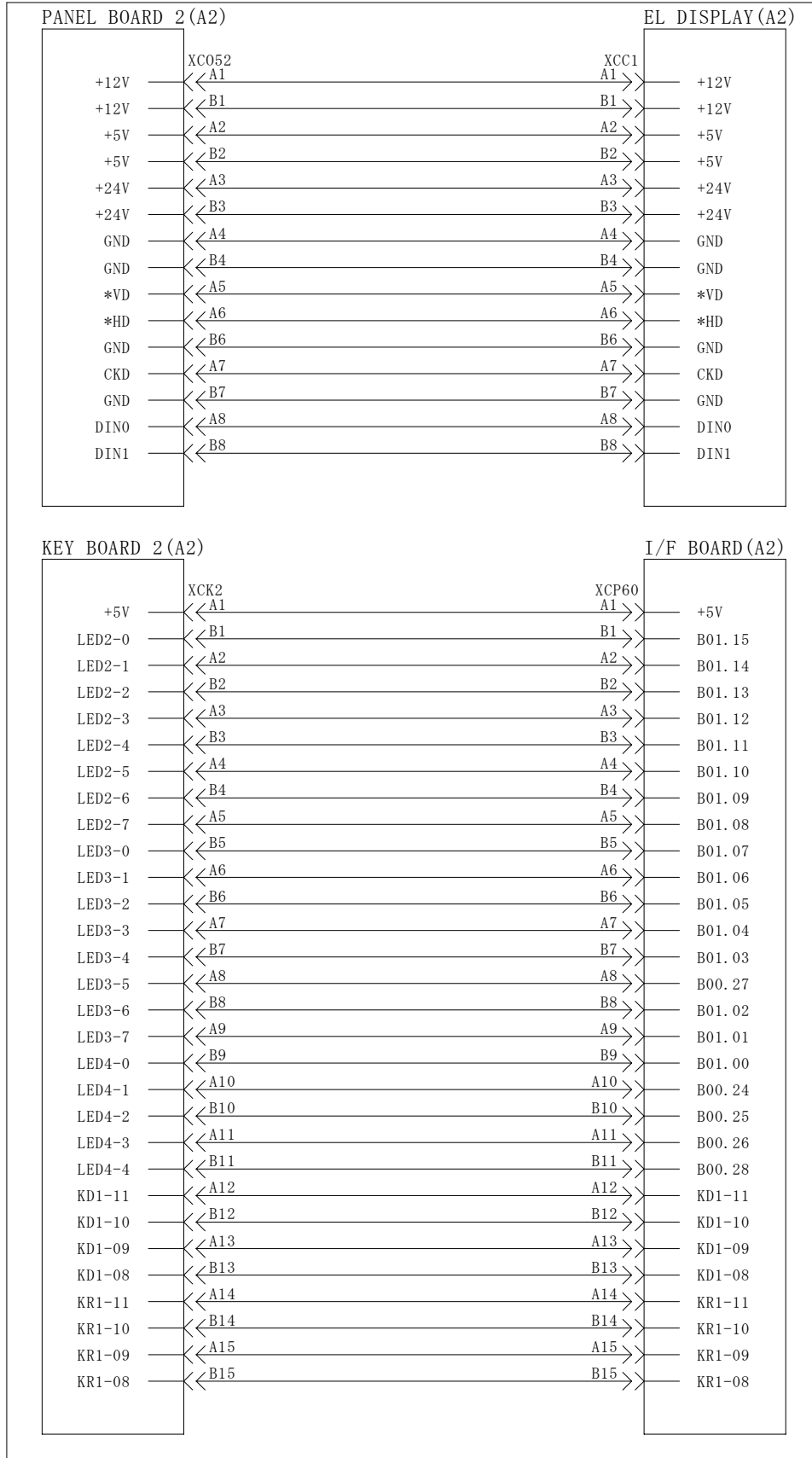

STD	48	510	612	
CE	1.5Kw	2.5Kw	4Kw	

△		 YAMAZAKI MAZAK CORPORATION	APR' D BY	CHK' D BY	DRWN BY	TITLE
△			99/11/30	99/11/30	99/11/30	NC OPERATING PANEL CONNECTION(2)
△			T. Inoue	M Okaji ma	M Okaji ma	DRWN NO. 676 001 40230, 0
△						
△						

This product is subject to all the applicable Japanese Foreign Exchange and Foreign Trade Law.
 本品は『外国為替及び外国貿易法』に該当しますので外国に輸出する場合には同法に基づく許可を必要とします。

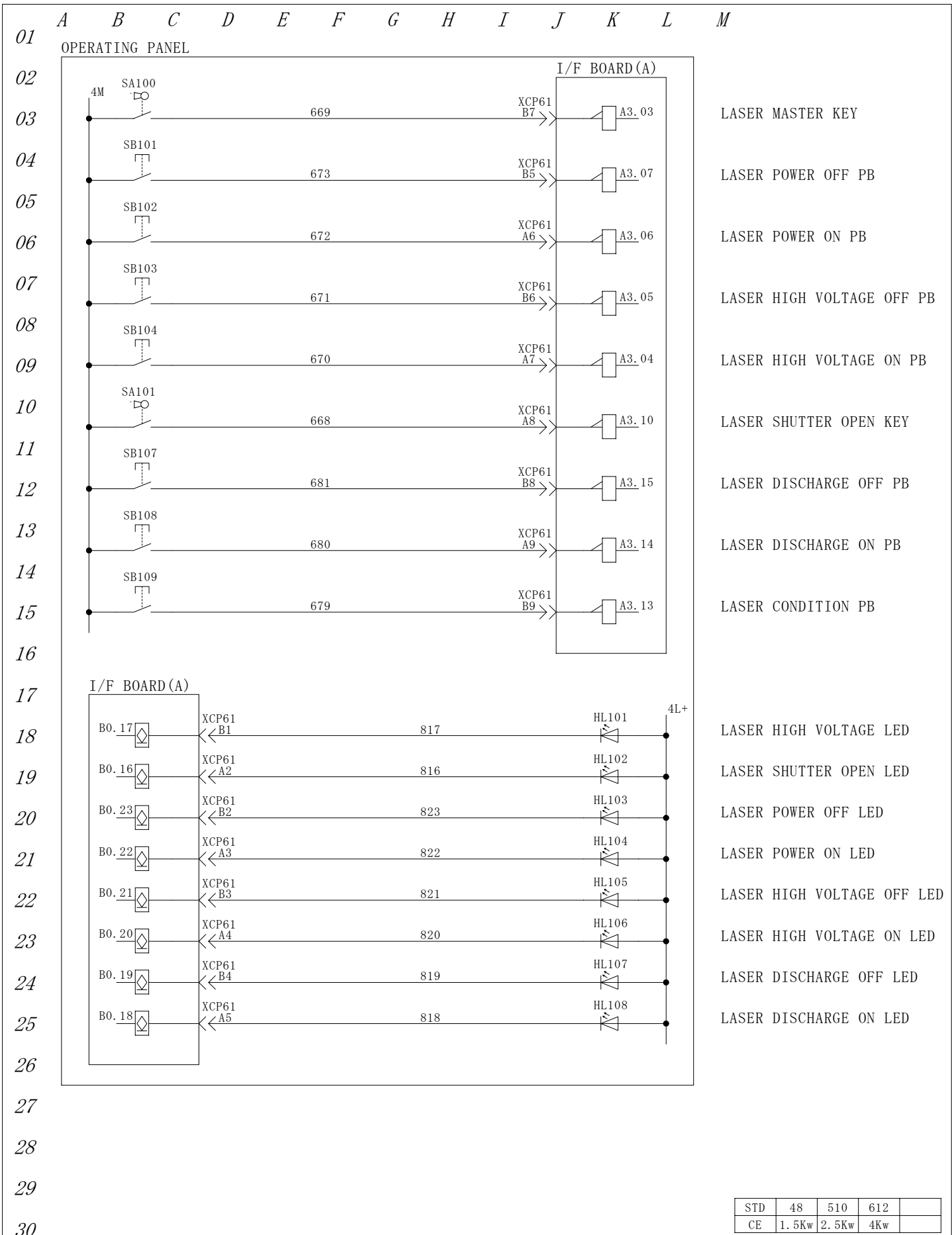

STD	48	510	612	
CE	1.5Kw	2.5Kw	4Kw	

△		 YAMAZAKI MAZAK CORPORATION	APR'D BY	CHK'D BY	DRWN BY	TITLE
△			99/11/30	99/11/30	99/11/30	NC OPERATING SWITCH(1)
△			T. Inoue	M Okaji ma	M Okaji ma	
△						DRWN NO. 676 001 40250, 0
△						

This product is subject to all the applicable Japanese Foreign Exchange and Foreign Trade Law.
 本品は『外国為替及び外国貿易法』に該当しますので外国に輸出する場合には同法に基づく許可を必要とします。

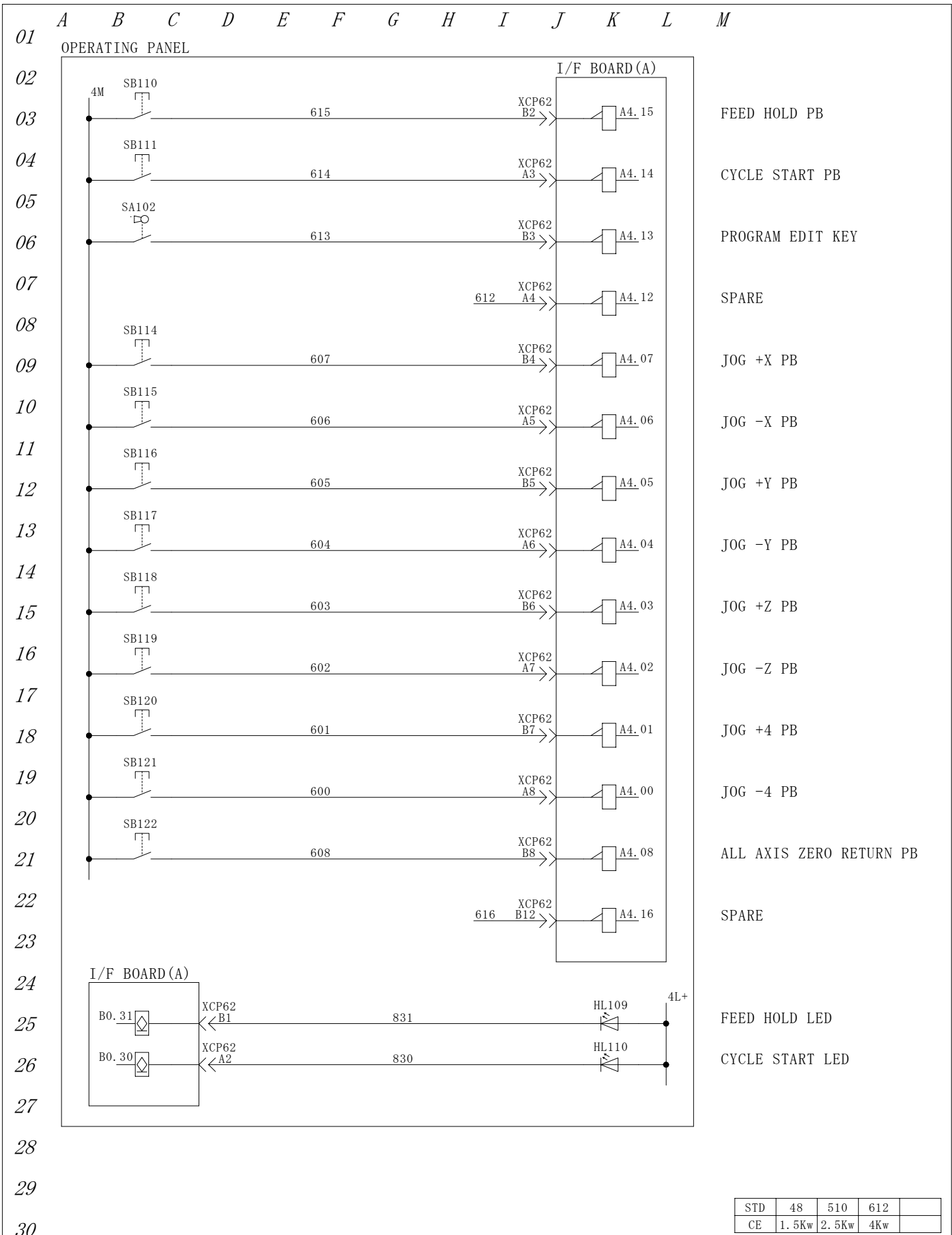

STD	48	510	612	
CE	1.5Kw	2.5Kw	4Kw	

APR' D BY	CHK' D BY	DRWN BY	TITLE
99/11/30	99/11/30	99/11/30	NC OPERATING SWITCH(2)
T. Inoue	M Okaji ma	M Okaji ma	DRWN NO. 676 001 40260, 0



This product is subject to all the applicable Japanese Foreign Exchange and Foreign Trade Law.
 本品は『外国為替及び外国貿易法』に該当しますので外国に輸出する場合には同法に基づく許可を必要とします。

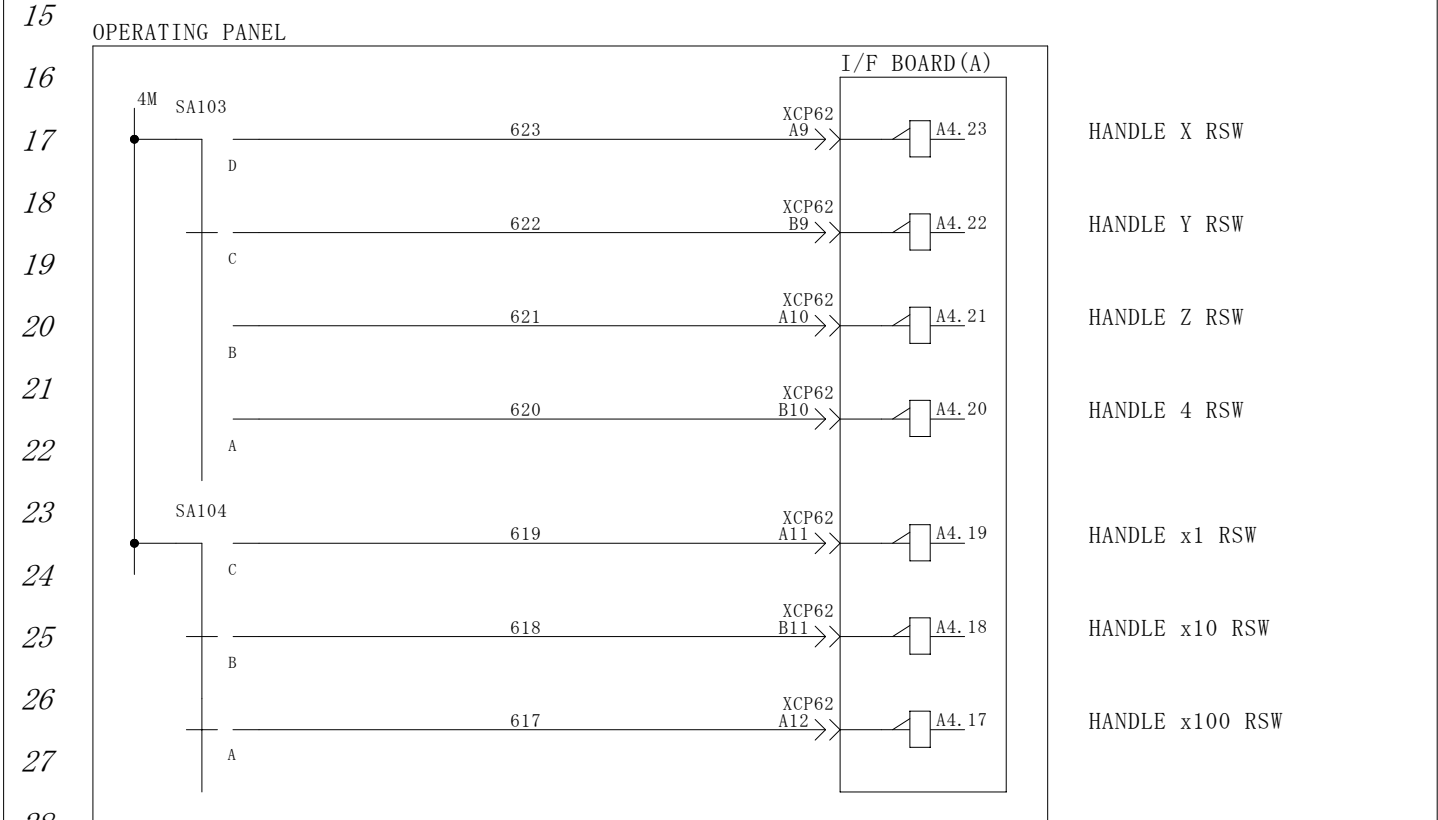
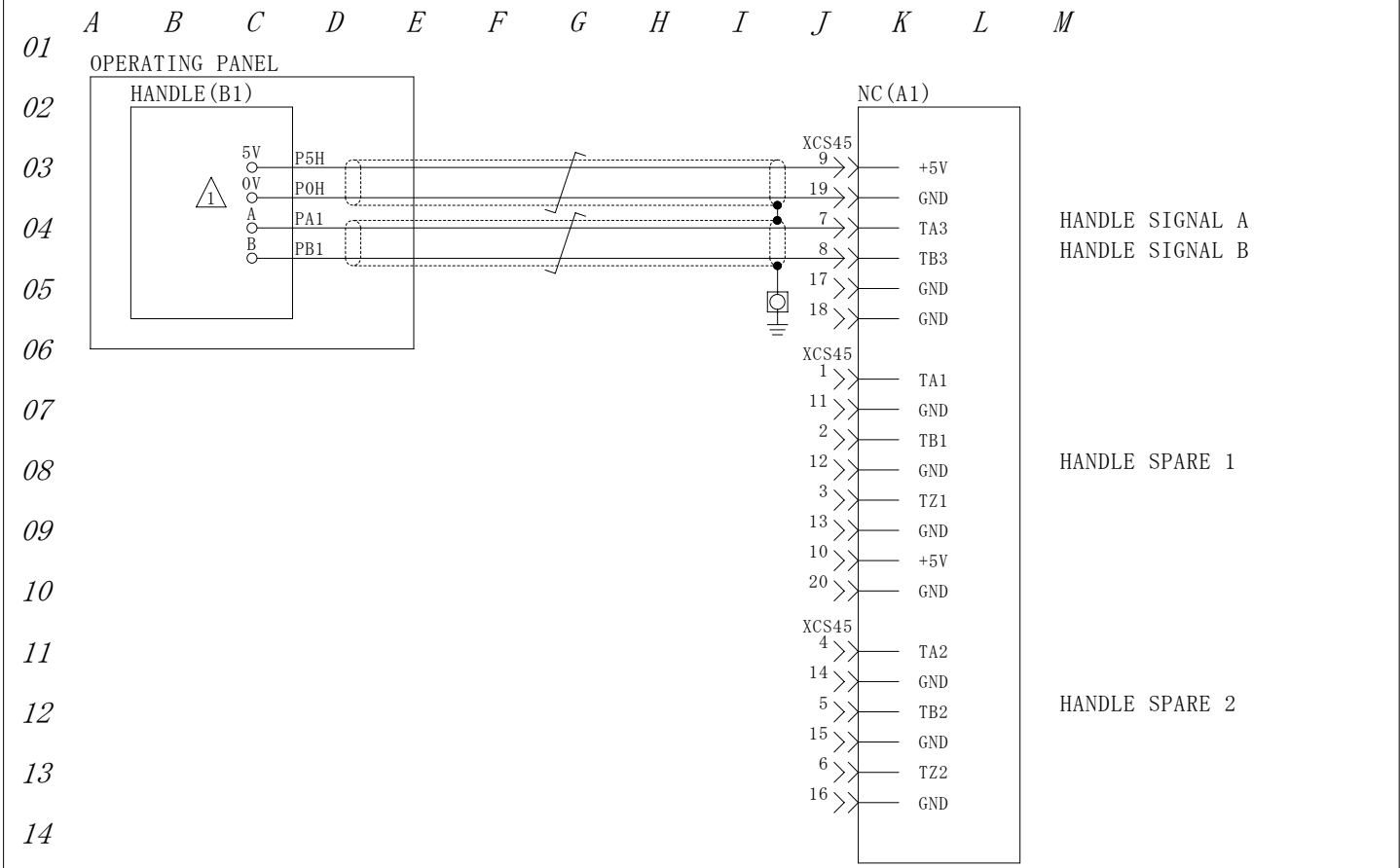

STD	48	510	612	
CE	1.5Kw	2.5Kw	4Kw	

△		 YAMAZAKI MAZAK CORPORATION	APR'D BY	CHK'D BY	DRWN BY	TITLE
△			99/11/30	99/11/30	99/11/30	NC HANDLE INTERFACE
△			T. Inoue	M Okajima	M Okajima	DRWN NO.
△	Edition Jun.03.'04 M.Okajima					676 001 40271,0

This product is subject to all the applicable Japanese Foreign Exchange and Foreign Trade Law.
 本品は『外国為替及び外国貿易法』に該当しますので外国に輸出する場合には同法に基づく許可を必要とします。

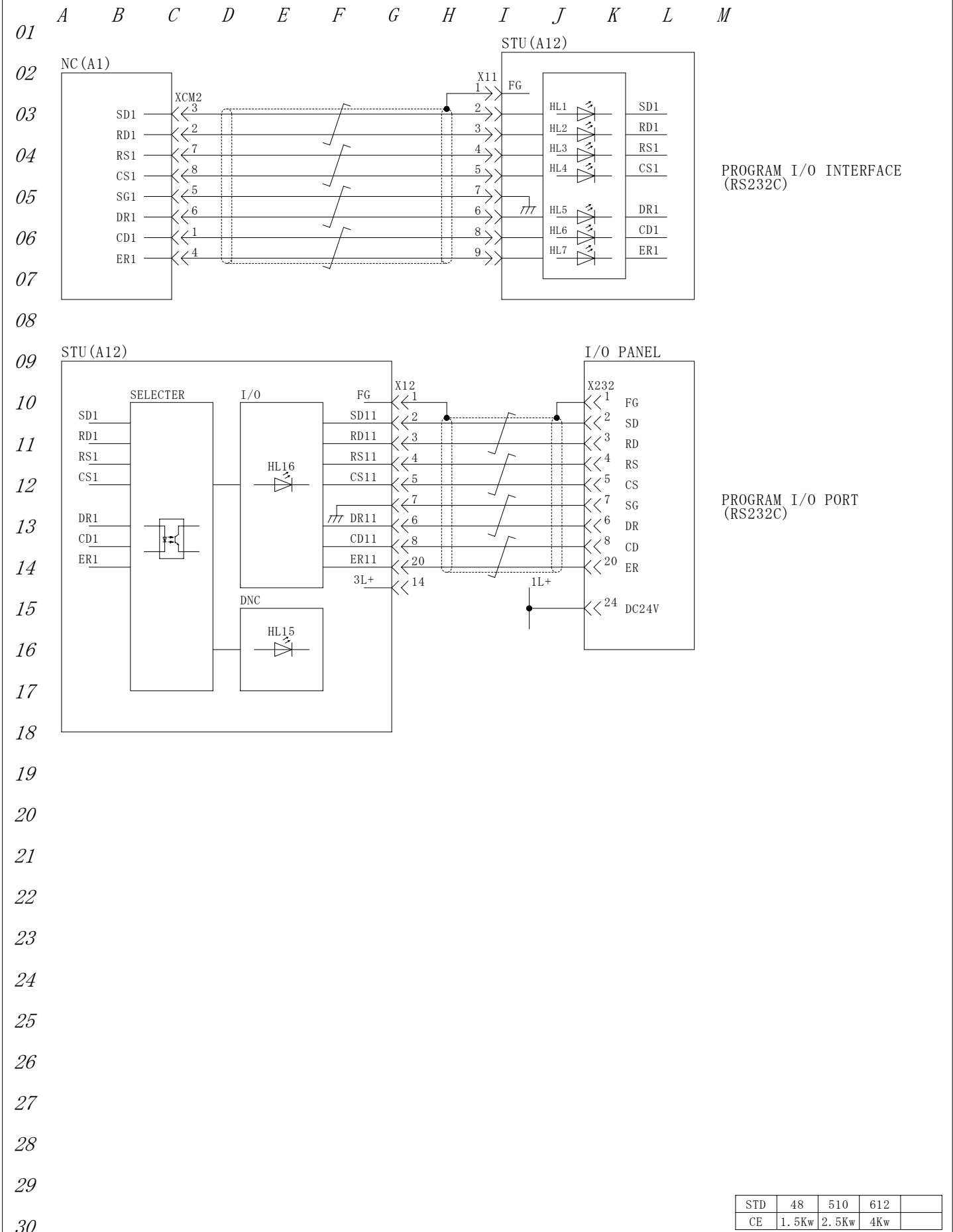

PROGRAM I/O INTERFACE (RS232C)

PROGRAM I/O PORT (RS232C)

STD	48	510	612	
CE	1.5Kw	2.5Kw	4Kw	

△		 YAMAZAKI MAZAK CORPORATION	APR'D BY	CHK'D BY	DRWN BY	TITLE
△			99/11/30	99/11/30	99/11/30	PROGRAM I/O INTERFACE
△			T. Inoue	M Okajima	M Okajima	
△						DRWN NO. 676 001 40300, 0
△						

This product is subject to all the applicable Japanese Foreign Exchange and Foreign Trade Law.
 本品は『外国為替及び外国貿易法』に該当しますので外国に輸出する場合には同法に基づく許可を必要とします。

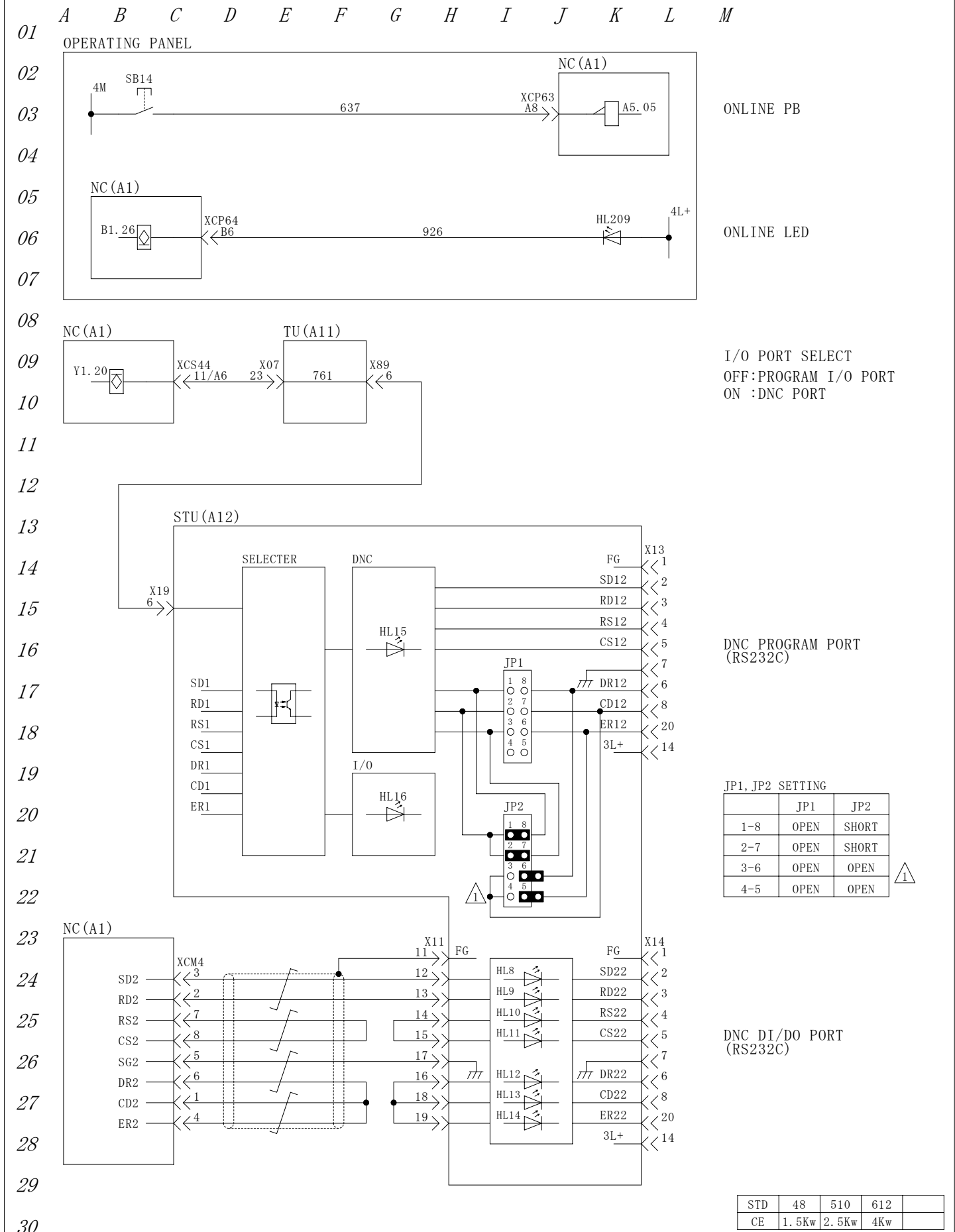

APR'D BY	CHK'D BY	DRWN BY	TITLE
99/11/30	99/11/30	99/11/30	DNC INTERFACE (OPTION)
T. Inoue	M Okajima	M Okajima	DRWN NO. 676 001 40311, 0



This product is subject to all the applicable Japanese Foreign Exchange and Foreign Trade Law.
 本品は『外国為替及び外国貿易法』に該当しますので外国に輸出する場合には同法に基づく許可を必要とします。

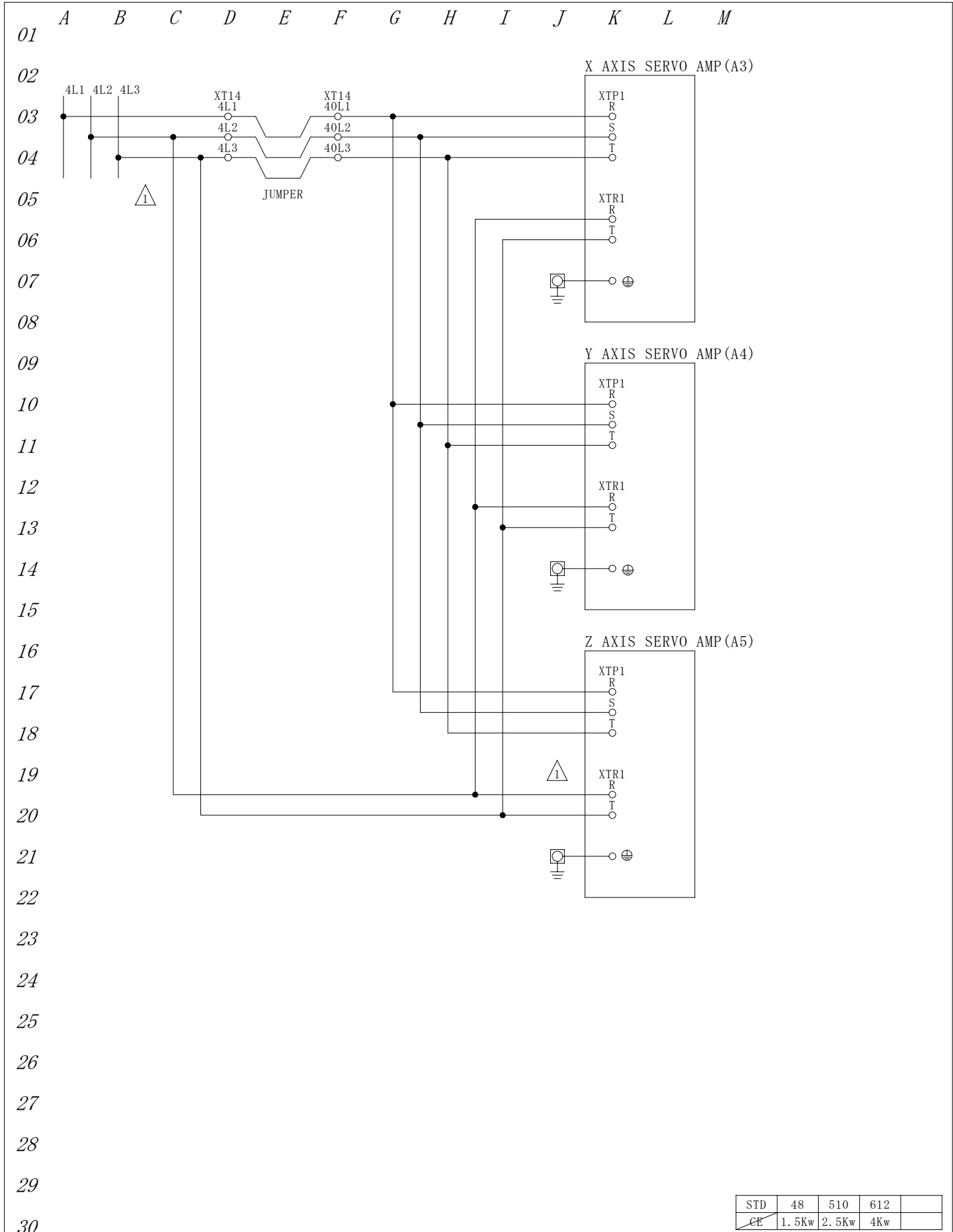

STD	48	510	612	
CE	1.5Kw	2.5Kw	4Kw	

△		 YAMAZAKI MAZAK CORPORATION	APR'D BY	CHK'D BY	DRWN BY	TITLE
△			99/11/30	99/11/30	99/11/30	SERVO AMP POWER CONNECTION
△			T. Inoue	M Okajima	M Okajima	DRWN NO. 676 001 40401, 0
△	Edition May.12.'00 M.Okajima					

This product is subject to all the applicable Japanese Foreign Exchange and Foreign Trade Law.
 本品は『外国為替及び外国貿易法』に該当しますので外国に輸出する場合には同法に基づく許可を必要とします。

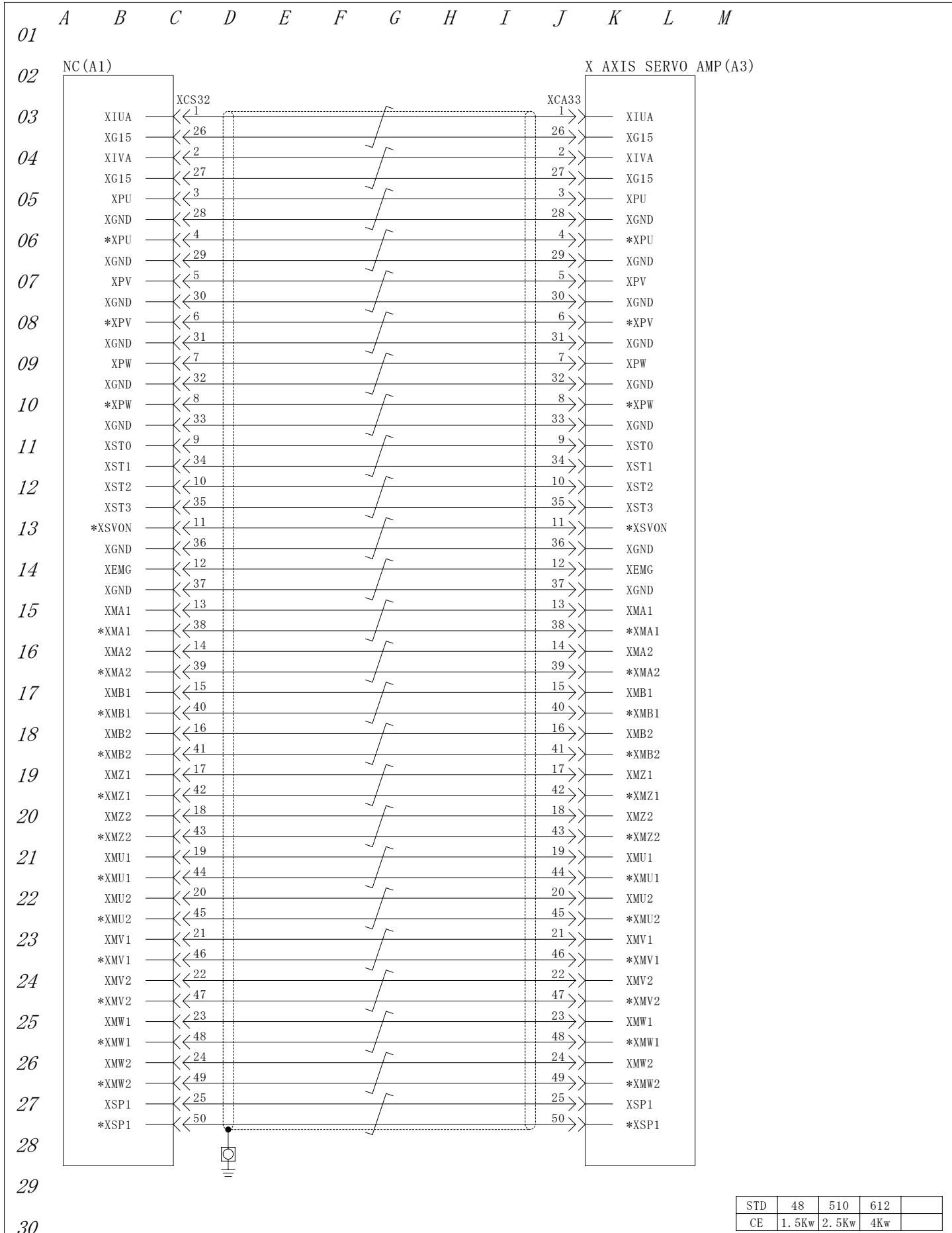

STD	48	510	612	
CE	1.5Kw	2.5Kw	4Kw	

△		 YAMAZAKI MAZAK CORPORATION	APR'D BY	CHK'D BY	DRWN BY	TITLE
△			99/11/30	99/11/30	99/11/30	X AXIS SERVO AMP
△			T. Inoue	M Okaji ma	M Okaji ma	
△						DRWN NO. 676 001 40450, 0

This product is subject to all the applicable Japanese Foreign Exchange and Foreign Trade Law.
 本品は『外国為替及び外国貿易法』に該当しますので外国に輸出する場合には同法に基づく許可を必要とします。

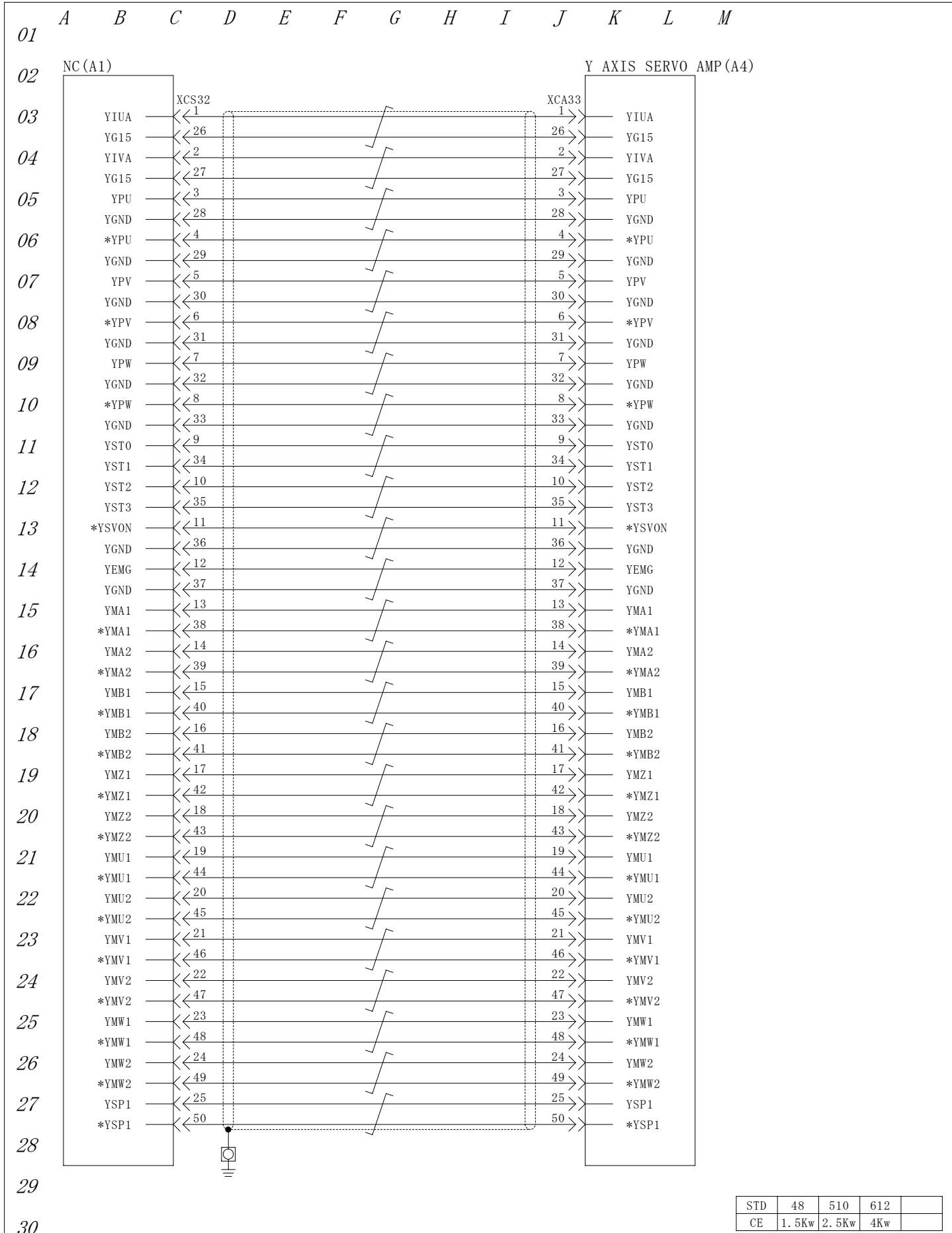

STD	48	510	612	
CE	1.5Kw	2.5Kw	4Kw	

△		 YAMAZAKI MAZAK CORPORATION	APR'D BY	CHK'D BY	DRWN BY	TITLE
△			99/11/30	99/11/30	99/11/30	Y AXIS SERVO AMP
△			T. Inoue	M Okaji ma	M Okaji ma	
△						DRWN NO. 676 001 40460, 0

This product is subject to all the applicable Japanese Foreign Exchange and Foreign Trade Law.
 本品は『外国為替及び外国貿易法』に該当しますので外国に輸出する場合には同法に基づく許可を必要とします。

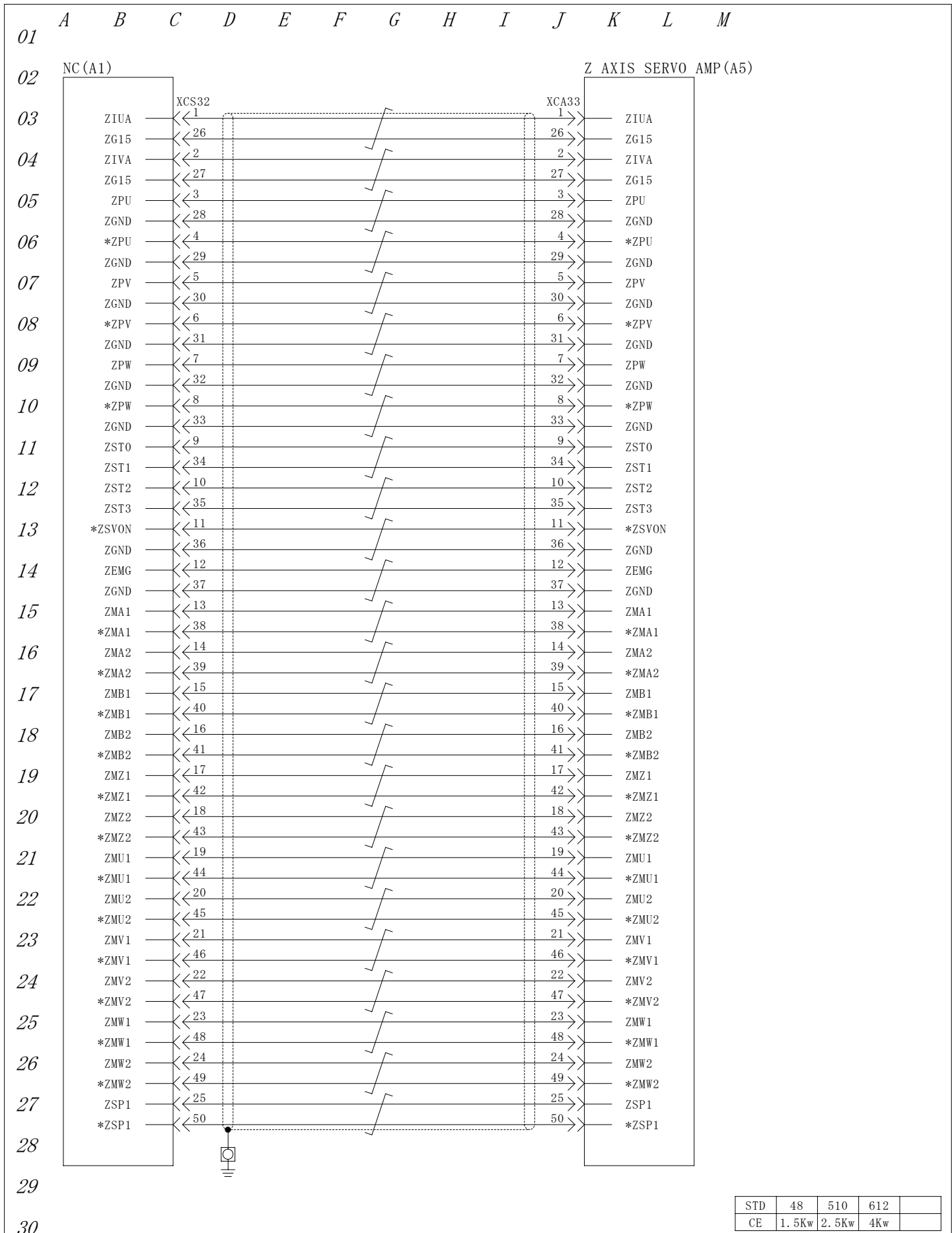

STD	48	510	612	
CE	1.5Kw	2.5Kw	4Kw	

△		 YAMAZAKI MAZAK CORPORATION	APR'D BY	CHK'D BY	DRWN BY	TITLE
△			99/11/30	99/11/30	99/11/30	Z AXIS SERVO AMP
△			T. Inoue	M Okajima	M Okajima	
△						DRWN NO. 676 001 40470, 0
△						

This product is subject to all the applicable Japanese Foreign Exchange and Foreign Trade Law.
 本品は『外国為替及び外国貿易法』に該当しますので外国に輸出する場合には同法に基づく許可を必要とします。

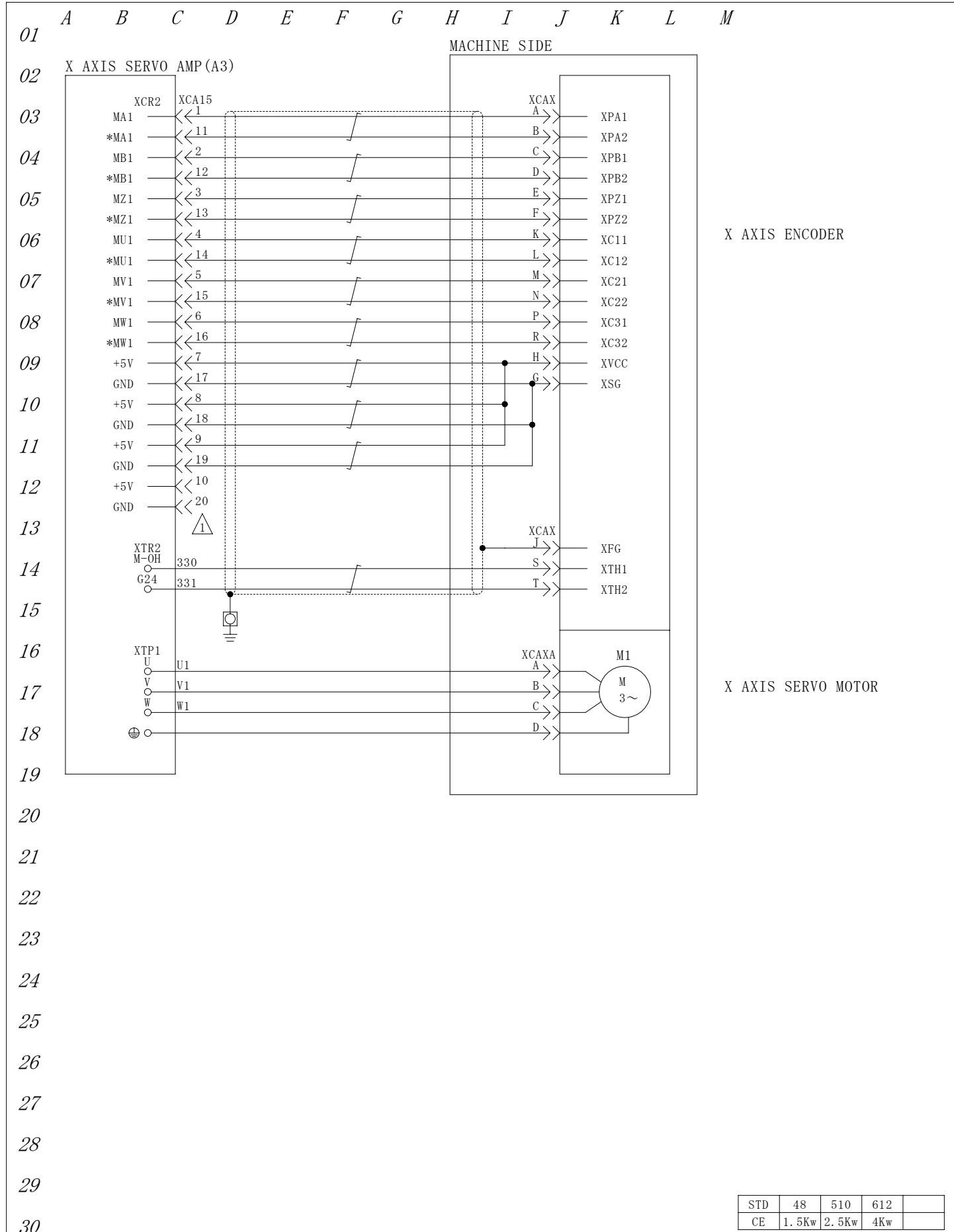

STD	48	510	612	
CE	1.5Kw	2.5Kw	4Kw	

	 YAMAZAKI MAZAK CORPORATION	APR'D BY	CHK'D BY	DRWN BY	TITLE
		99/11/30	99/11/30	99/11/30	X AXIS SERVO MOTOR
		T. Inoue	M Okajima	M Okajima	DRWN NO. 676 001 40501, 0

This product is subject to all the applicable Japanese Foreign Exchange and Foreign Trade Law.
 本品は『外国為替及び外国貿易法』に該当しますので外国に輸出する場合には同法に基づく許可を必要とします。

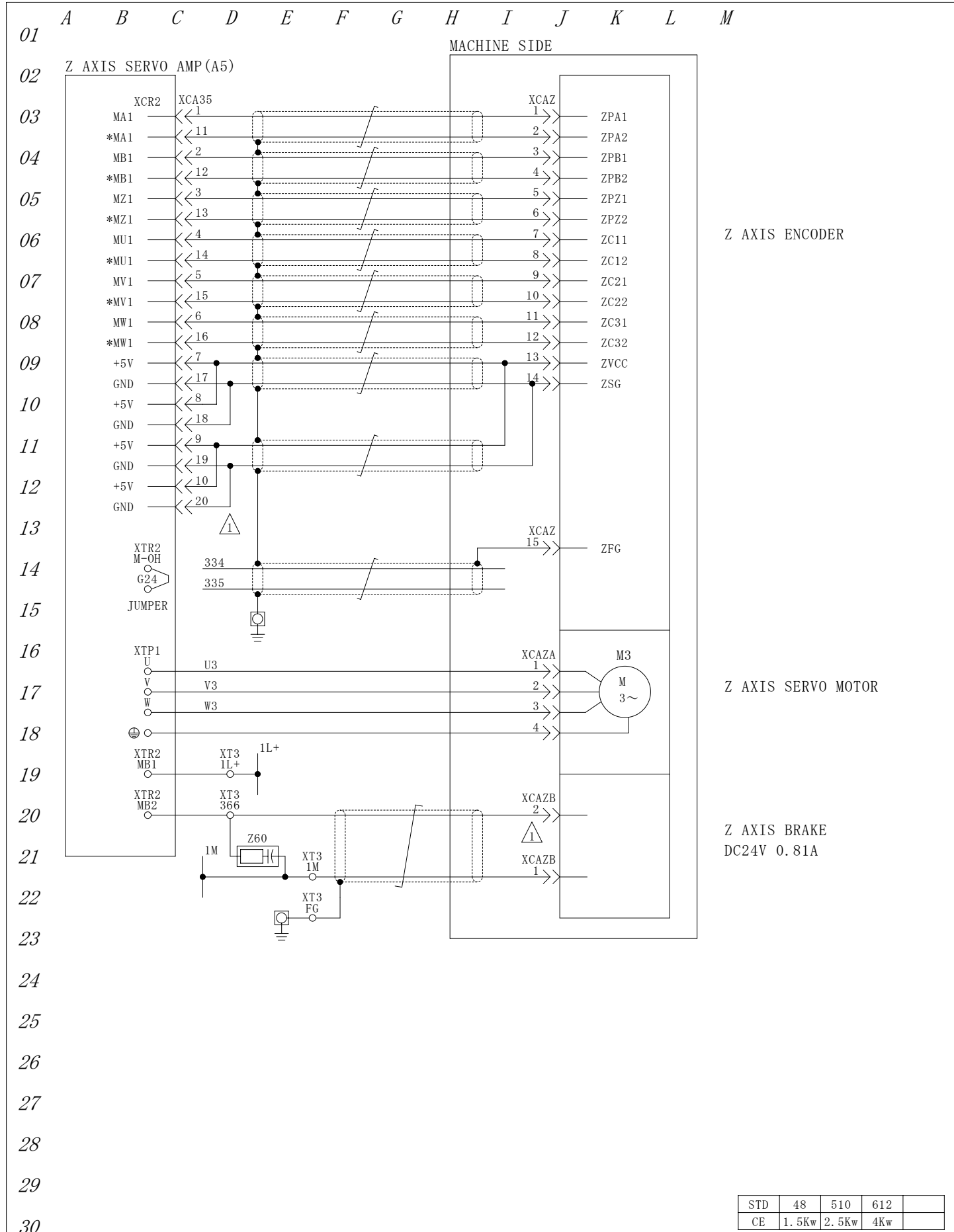

Z AXIS ENCODER

Z AXIS SERVO MOTOR

Z AXIS BRAKE
DC24V 0.81A

STD	48	510	612	
CE	1.5Kw	2.5Kw	4Kw	

	 YAMAZAKI MAZAK CORPORATION	APR'D BY 99/11/30 T. Inoue	CHK'D BY 99/11/30 M Okajima	DRWN BY 99/11/30 M Okajima	TITLE Z AXIS SERVO MOTOR DRWN NO. 676 001 40521, 0
	Edition Jun.03.'04 M.Okajima				
	This product is subject to all the applicable Japanese Foreign Exchange and Foreign Trade Law. 本品は『外国為替及び外国貿易法』に該当しますので外国に輸出する場合には同法に基づく許可を必要とします。				

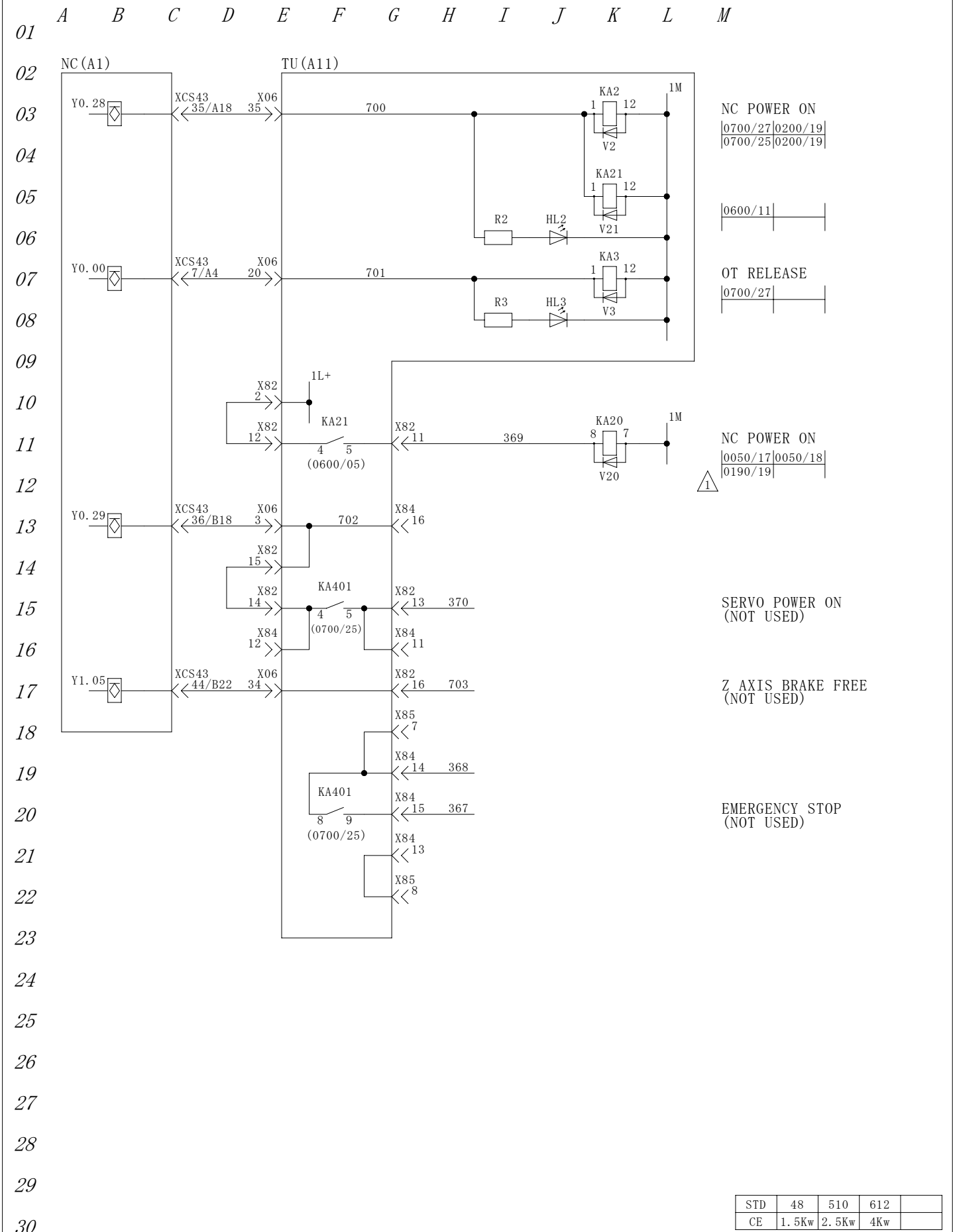

NC POWER ON

0700/27	0200/19
0700/25	0200/19

0600/11

OT RELEASE

0700/27

NC POWER ON

0050/17	0050/18
0190/19	

SERVO POWER ON
(NOT USED)

Z AXIS BRAKE FREE
(NOT USED)

EMERGENCY STOP
(NOT USED)

STD	48	510	612	
CE	1.5Kw	2.5Kw	4Kw	

		 YAMAZAKI MAZAK CORPORATION	APR'D BY	CHK'D BY	DRWN BY	TITLE
			T. Inoue	M Okajima	M Okajima	POWER ON
						DRWN NO. 676 001 40601, 0

This product is subject to all the applicable Japanese Foreign Exchange and Foreign Trade Law.
 本品は『外国為替及び外国貿易法』に該当しますので外国に輸出する場合には同法に基づく許可を必要とします。

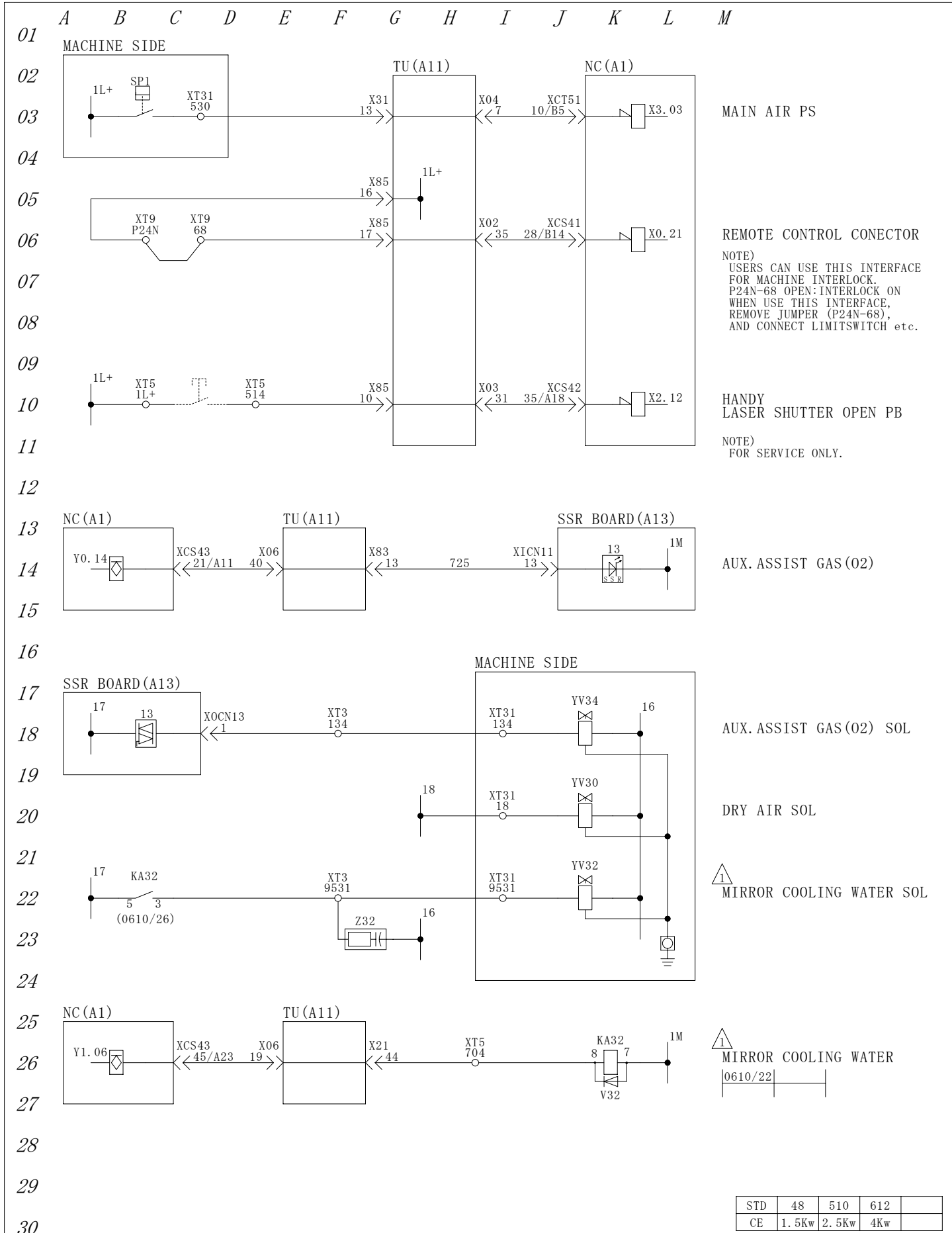

MAIN AIR PS

REMOTE CONTROL CONECTOR

NOTE)
USERS CAN USE THIS INTERFACE FOR MACHINE INTERLOCK. P24N-68 OPEN: INTERLOCK ON WHEN USE THIS INTERFACE, REMOVE JUMPER (P24N-68), AND CONNECT LIMITSWITCH etc.

HANDY LASER SHUTTER OPEN PB

NOTE)
FOR SERVICE ONLY.

AUX. ASSIST GAS (02)

AUX. ASSIST GAS (02) SOL

DRY AIR SOL

MIRROR COOLING WATER SOL

MIRROR COOLING WATER

STD	48	510	612	
CE	1.5Kw	2.5Kw	4Kw	

△		 YAMAZAKI MAZAK CORPORATION	APR'D BY	CHK'D BY	DRWN BY	TITLE	
△			99/11/30	99/11/30	99/11/30	INTERLOCK	
△			T. Inoue	M Okajima	M Okajima		
△			Edition Aug.01.'00 M.Okajima				
						DRWN NO.	676 001 40611, 0

This product is subject to all the applicable Japanese Foreign Exchange and Foreign Trade Law.
 本品は『外国為替及び外国貿易法』に該当しますので外国に輸出する場合には同法に基づく許可を必要とします。

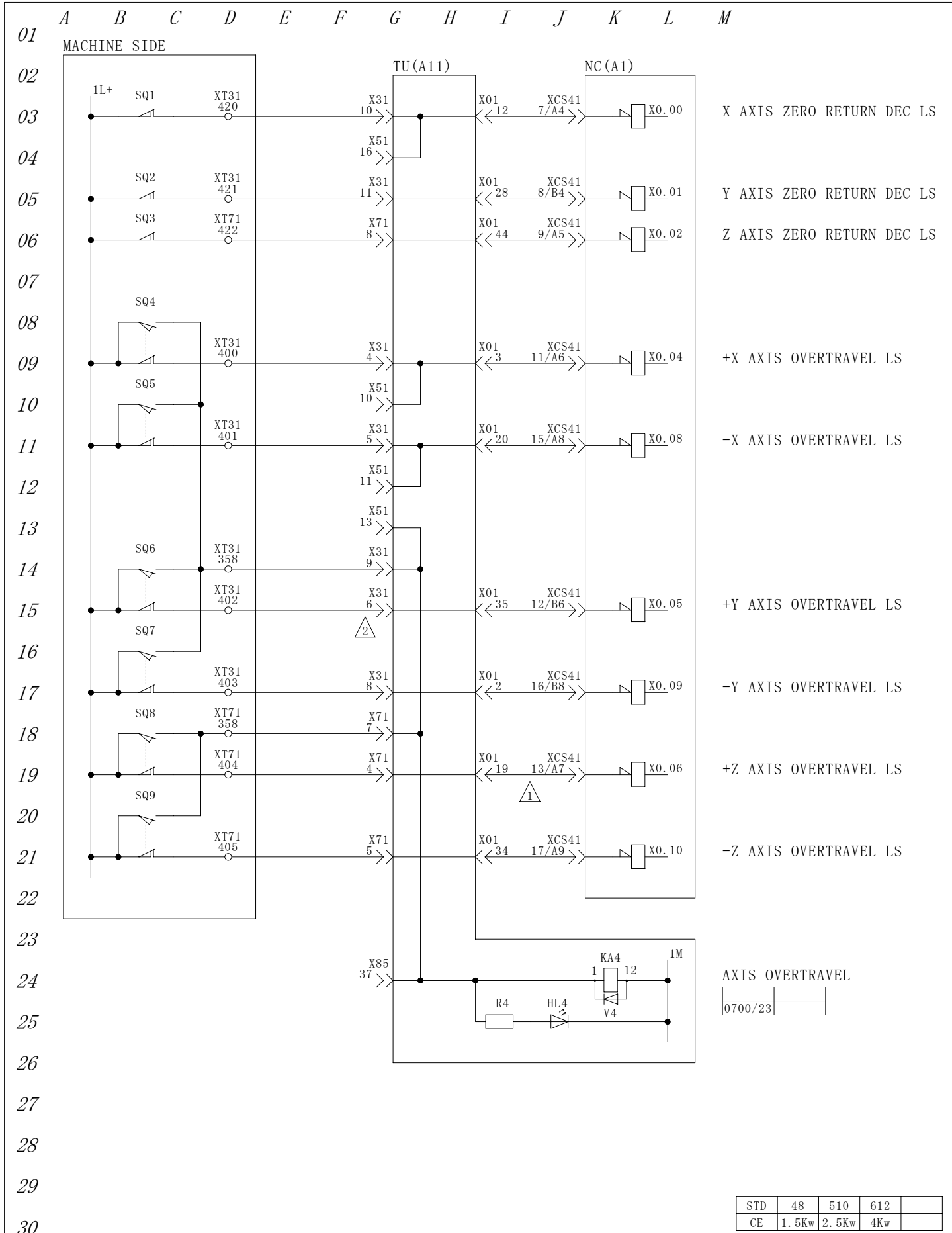

STD	48	510	612	
CE	1.5Kw	2.5Kw	4Kw	

	APR'D BY	CHK'D BY	DRWN BY	TITLE
	99/11/30	99/11/30	99/11/30	AXIS LS
	T. Inoue	M Okajima	M Okajima	DRWN NO. 676 001 40652, 0

This product is subject to all the applicable Japanese Foreign Exchange and Foreign Trade Law.
 本品は『外国為替及び外国貿易法』に該当しますので外国に輸出する場合には同法に基づく許可を必要とします。

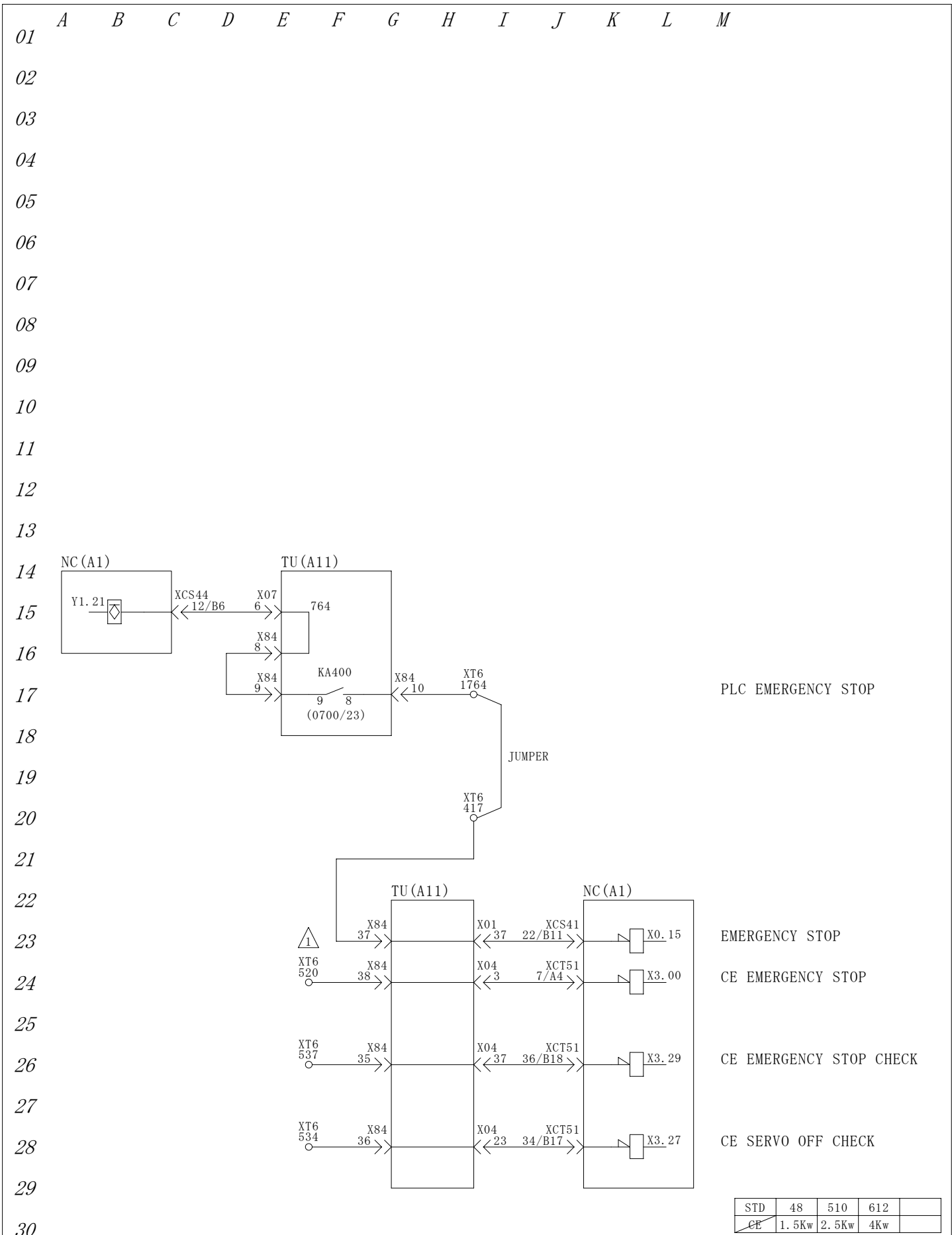

PLC EMERGENCY STOP

EMERGENCY STOP

CE EMERGENCY STOP

CE EMERGENCY STOP CHECK

CE SERVO OFF CHECK

STD	48	510	612	
CE	1.5Kw	2.5Kw	4Kw	

△		 YAMAZAKI MAZAK CORPORATION	APR'D BY	CHK'D BY	DRWN BY	TITLE
△			99/11/30	99/11/30	99/11/30	EMERGENCY STOP (2)
△			T. Inoue	M Okajima	M Okajima	
△	Edition Oct.05.'00 M.Okajima					DRWN NO. 676 001 40711,0

This product is subject to all the applicable Japanese Foreign Exchange and Foreign Trade Law.
 本品は『外国為替及び外国貿易法』に該当しますので外国に輸出する場合には同法に基づく許可を必要とします。

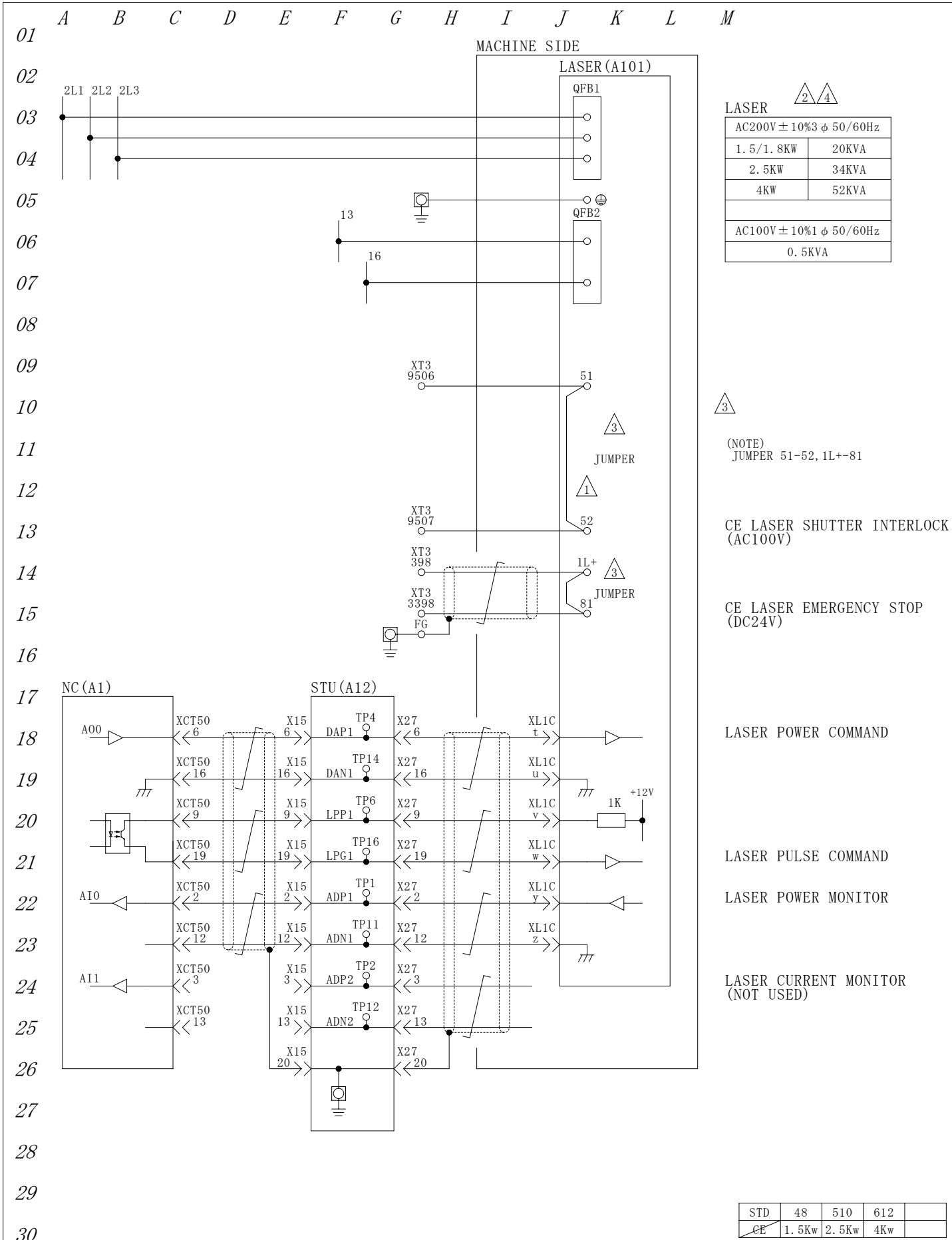

(NOTE)
JUMPER 51-52, 1L+-81

CE LASER SHUTTER INTERLOCK (AC100V)

CE LASER EMERGENCY STOP (DC24V)

LASER POWER COMMAND

LASER PULSE COMMAND

LASER POWER MONITOR

LASER CURRENT MONITOR (NOT USED)

STD	48	510	612	
CE	1.5Kw	2.5Kw	4Kw	

▲ Edition Jul.05.'01 M.Okajima ▲ Edition Oct.05.'00 M.Okajima ▲ Edition Jul.01.'00 M.Okajima ▲ Edition May.12.'00 M.Okajima	 YAMAZAKI MAZAK CORPORATION	APR'D BY 99/11/30 T. Inoue	CHK'D BY 99/11/30 M Okajima	DRWN BY 99/11/30 M Okajima	TITLE LASER UNIT(1) DRWN NO. 676 001 40804, 0
--	---	----------------------------------	-----------------------------------	----------------------------------	---

This product is subject to all the applicable Japanese Foreign Exchange and Foreign Trade Law.
 本品は『外国為替及び外国貿易法』に該当しますので外国に輸出する場合には同法に基づく許可を必要とします。

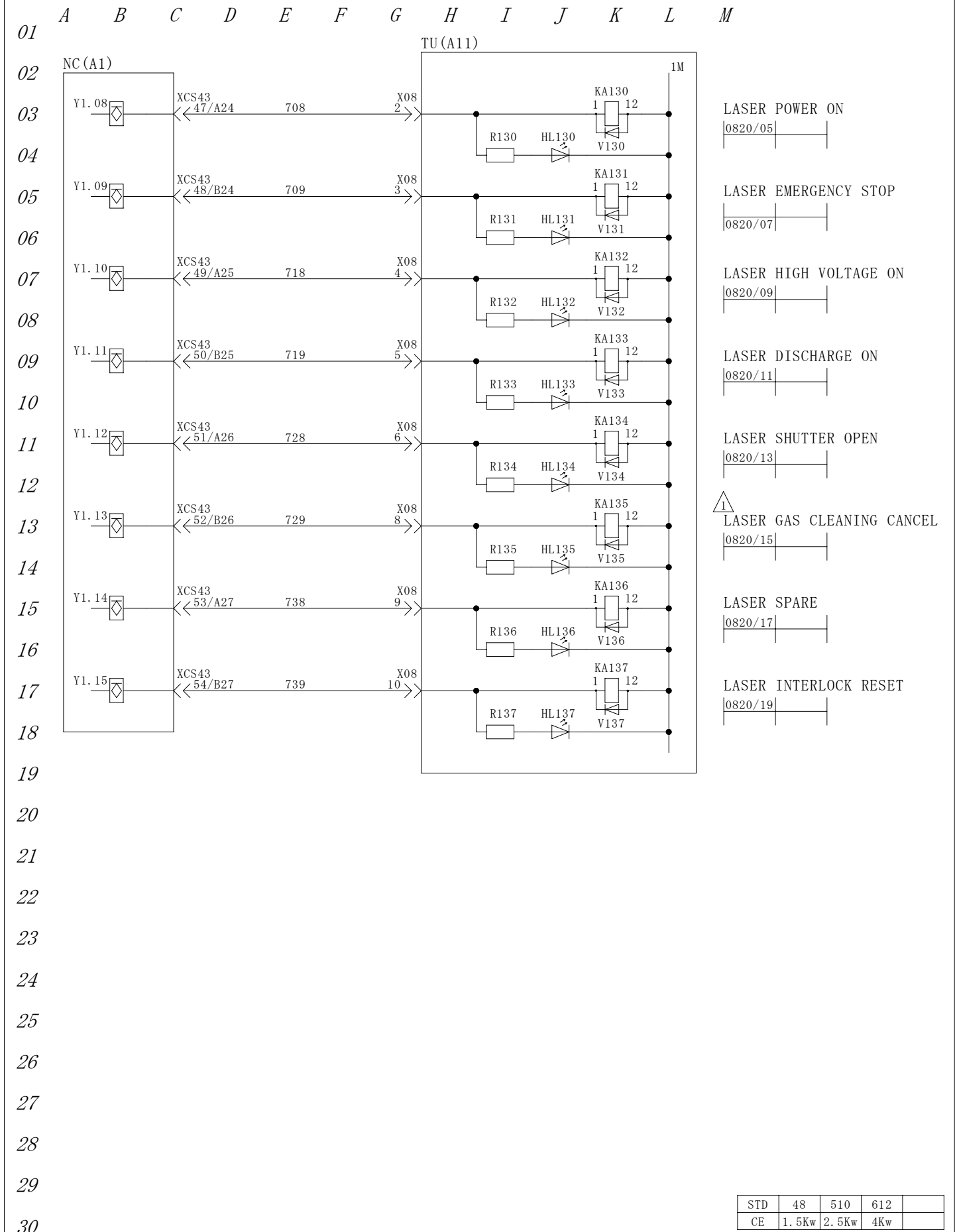

STD	48	510	612	
CE	1.5Kw	2.5Kw	4Kw	

APR'D BY	CHK'D BY	DRWN BY	TITLE
99/11/30	99/11/30	99/11/30	LASER UNIT (2)
T. Inoue	M Okajima	M Okajima	DRWN NO. 676 001 40811, 0



This product is subject to all the applicable Japanese Foreign Exchange and Foreign Trade Law.
 本品は『外国為替及び外国貿易法』に該当しますので外国に輸出する場合には同法に基づく許可を必要とします。

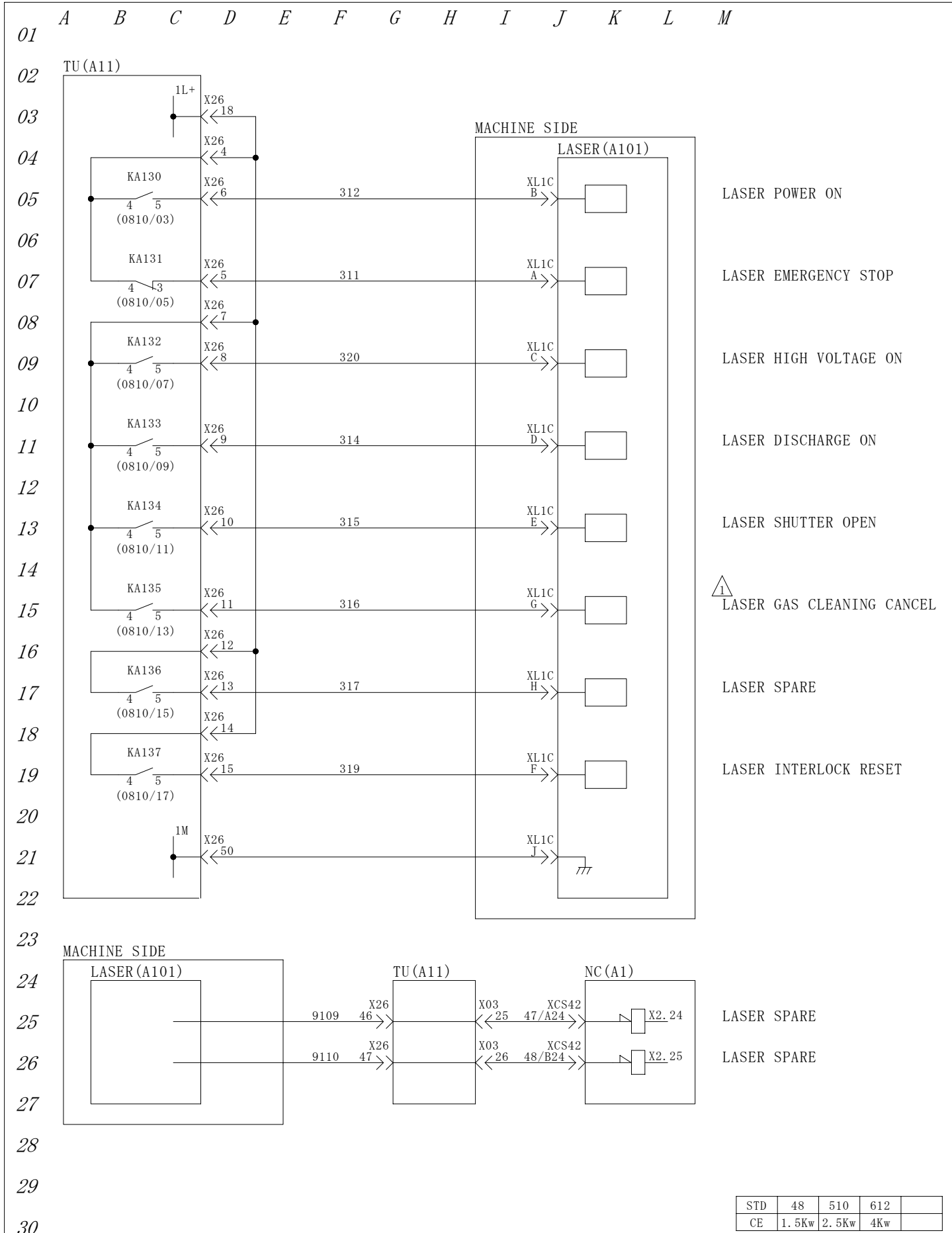

LASER GAS CLEANING CANCEL

LASER SPARE

LASER INTERLOCK RESET

LASER SPARE

LASER SPARE

STD	48	510	612	
CE	1.5Kw	2.5Kw	4Kw	

 	 YAMAZAKI MAZAK CORPORATION	APR'D BY	CHK'D BY	DRWN BY	TITLE
		99/11/30	99/11/30	99/11/30	LASER UNIT(3)
		T. Inoue	M Okajima	M Okajima	DRWN NO. 676 001 40821, 0

This product is subject to all the applicable Japanese Foreign Exchange and Foreign Trade Law.
 本品は『外国為替及び外国貿易法』に該当しますので外国に輸出する場合には同法に基づく許可を必要とします。

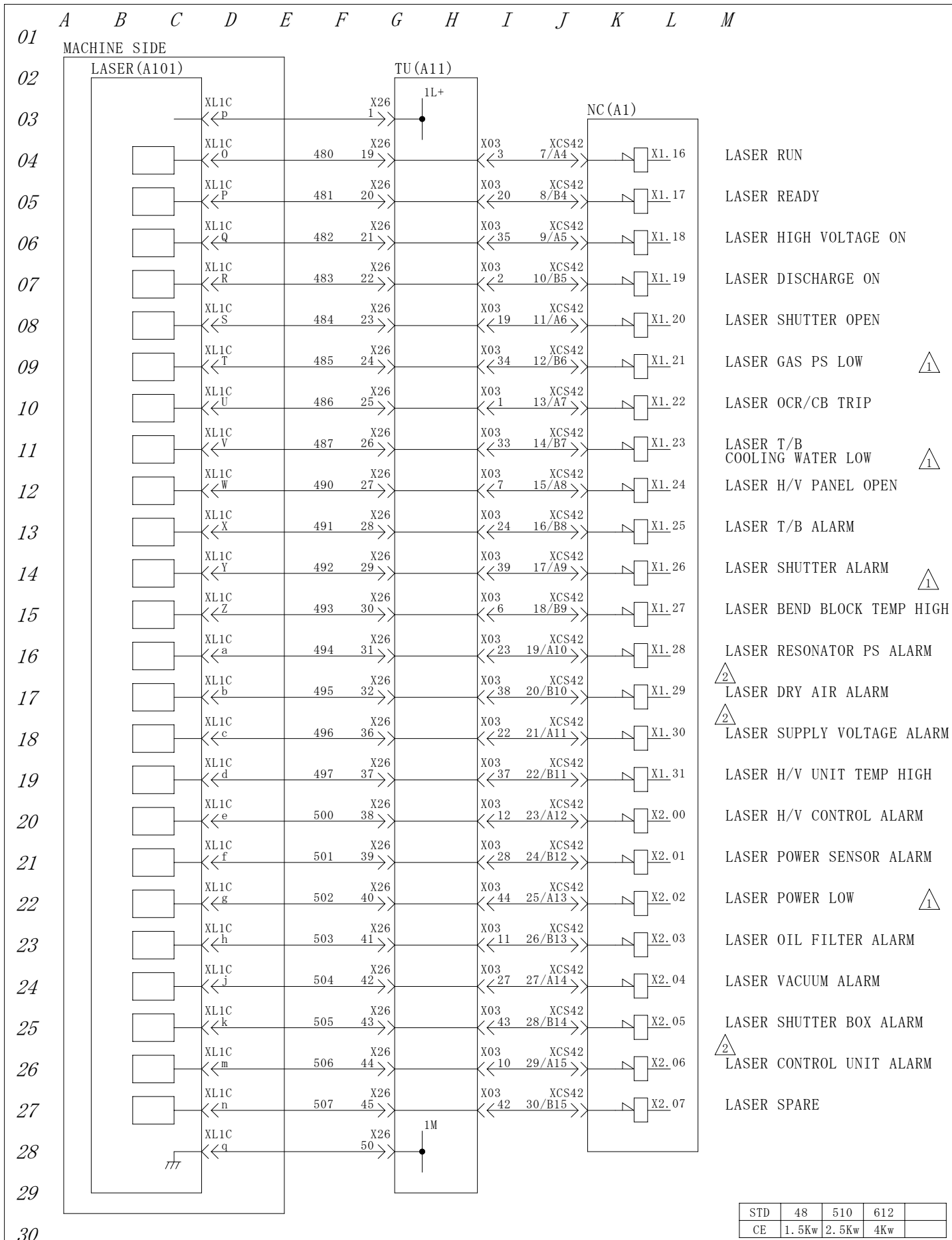

STD	48	510	612	
CE	1.5Kw	2.5Kw	4Kw	

△		 YAMAZAKI MAZAK CORPORATION	APR' D BY	CHK' D BY	DRWN BY	TITLE
△			99/11/30	99/11/30	99/11/30	LASER UNIT (4)
△			T. Inoue	M Okaji ma	M Okaji ma	
△	Edition May.12.'00 M.Okajima		DRWN NO. 676 001 40832.0			
△	Edition Mar.27.'00 M.Okajima					

This product is subject to all the applicable Japanese Foreign Exchange and Foreign Trade Law.
 本品は『外国為替及び外国貿易法』に該当しますので外国に輸出する場合には同法に基づく許可を必要とします。

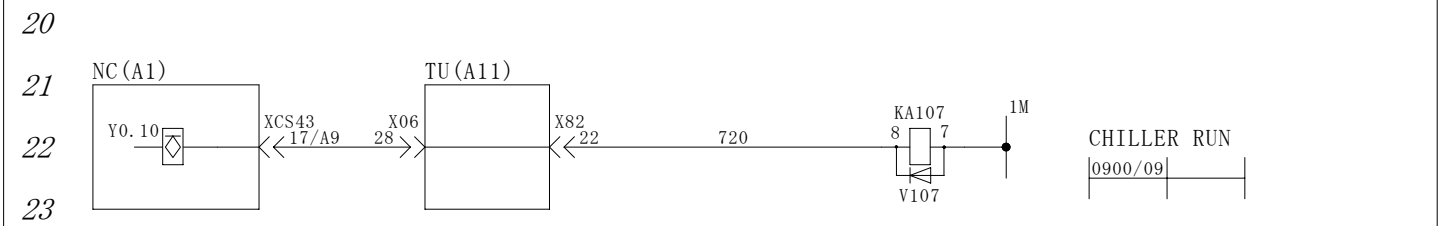
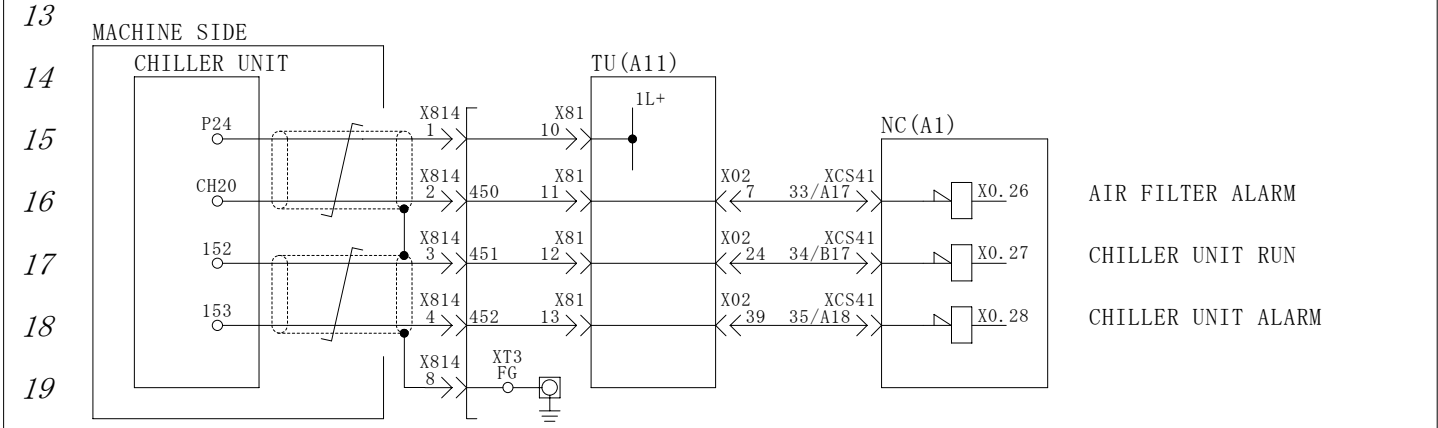
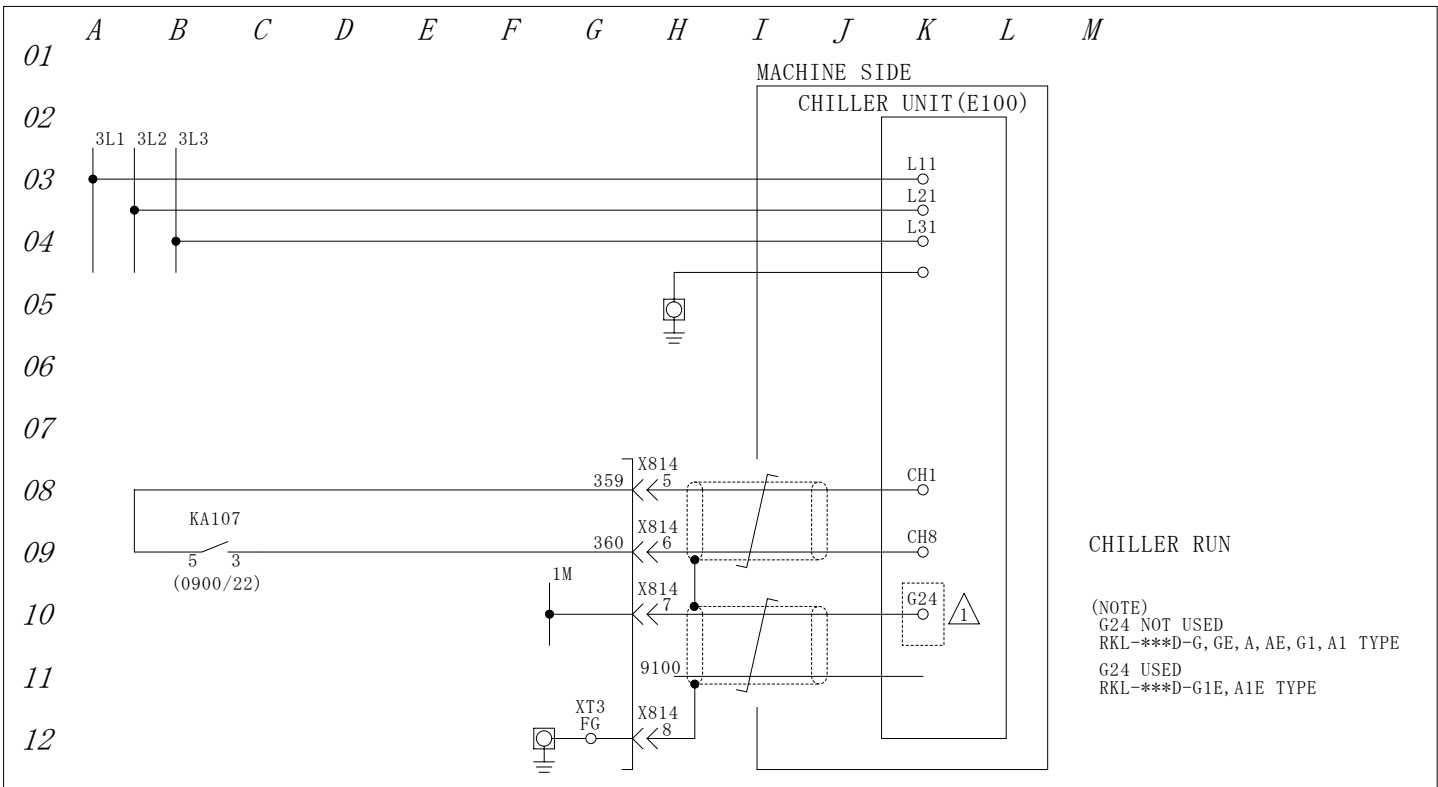

27 CHILLER UNIT

AC200V ± 10% 3φ 50/60Hz						
1.5/1.8KW	RKL-5500D-G, G1	8/10KW	30/34A	RKL-5500D-GE, G1E	8/10KW	30/34A
2.5KW	RKL-9000D-A, A1	17/21KW	57/69A	RKL-9000D-AE, A1E	18/22KW	63/74A
4KW	RKL-15000D-A, A1	26/31KW	90/98A	RKL-15000D-AE, A1E	25/31KW	81/95A

STD	48	510	612	
CE	1.5Kw	2.5Kw	4Kw	

APR' D BY 99/11/30 T. Inoue	CHK' D BY 99/11/30 M Okajima	DRWN BY 99/11/30 M Okajima	TITLE CHILLER UNIT DRWN NO. 676 001 40901, 0
-----------------------------------	------------------------------------	----------------------------------	--

Edition Jul.05.'01 M.Okajima

Mazak
YAMAZAKI MAZAK CORPORATION

This product is subject to all the applicable Japanese Foreign Exchange and Foreign Trade Law.
本品は『外国為替及び外国貿易法』に該当しますので外国に輸出する場合には同法に基づく許可を必要とします。

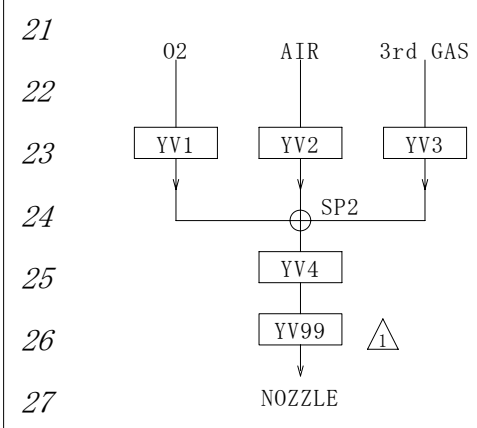
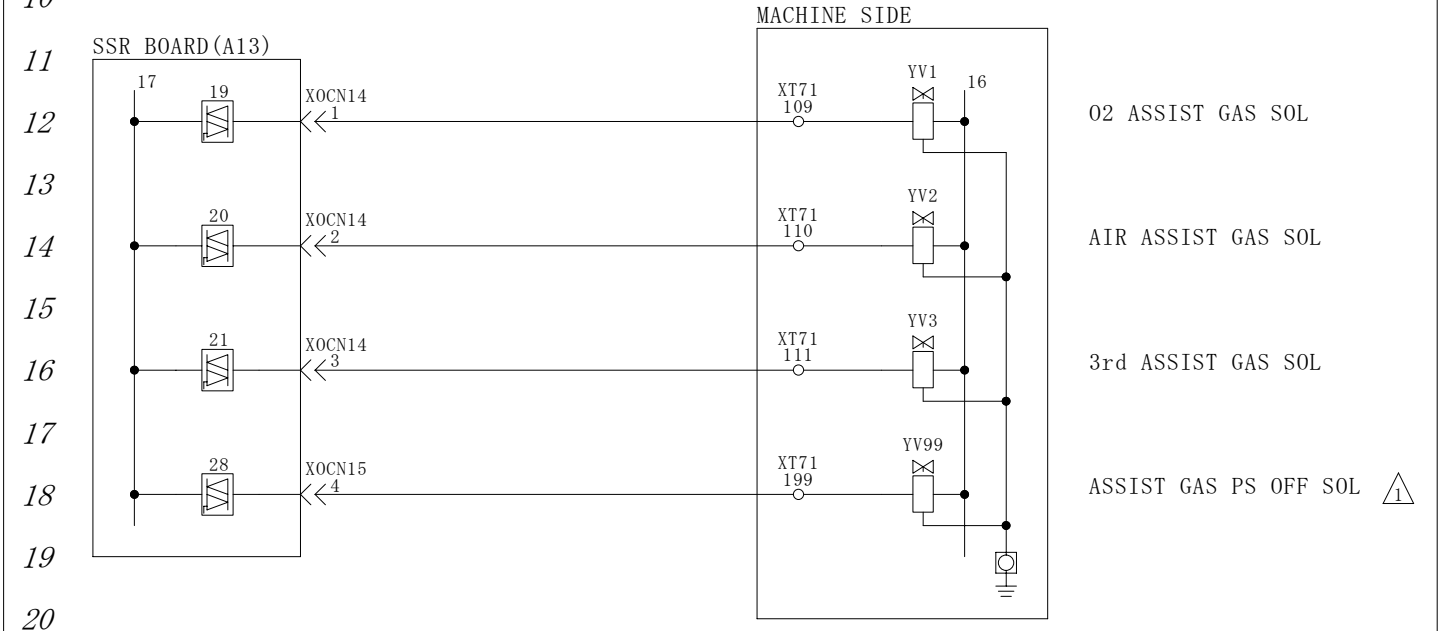
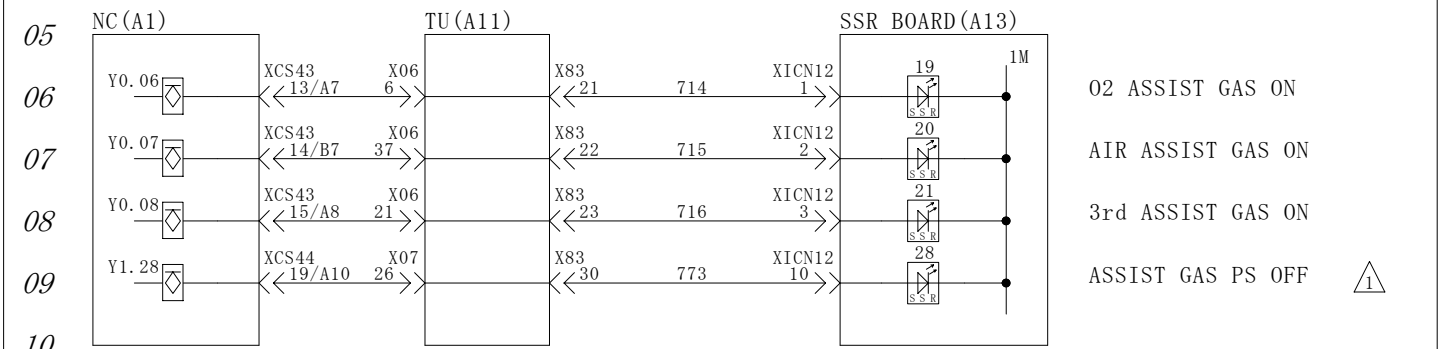
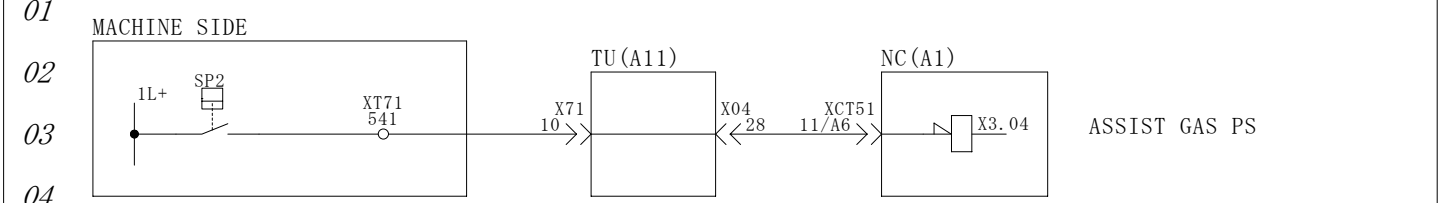

	M CODE	02 SOL	AIR SOL	3rd SOL	AGR
		YV1	YV2	YV3	YV4
02 HIGH	M50	○	×	×	Vh
02 LOW	M51	○	×	×	Vl
AIR HIGH	M52	×	○	×	Vh
AIR LOW	M53	×	○	×	Vl
3rd HIGH	M54	×	×	○	Vh
3rd LOW	M55	×	×	○	Vl
02 SELECT	M56	○	×	×	Vc
AIR SELECT	M57	×	○	×	Vc
3rd SELECT	M58	×	×	○	Vc
GAS STOP	M09	×	×	×	0V

○:ON ×:OFF

28 V : COMMAND VOLTAGE TO ASSIST GAS REGULATOR(YV4)

29 Vc:COMMAND VOLTAGE BY NC COMMAND G88

30 Vh:COMMAND VOLTAGE BY SETTING PARAMETER FOR HIGH ASSIST GAS

31 Vl:COMMAND VOLTAGE BY SETTING PARAMETER FOR LOW ASSIST GAS

STD	48	510	612	
CE	1.5Kw	2.5Kw	4Kw	

<p>\triangle</p> <p>\triangle</p> <p>\triangle</p> <p>\triangle</p> <p>Edition Mar. 28. '00 M. Okajima</p>	<p>YAMAZAKI MAZAK CORPORATION</p>	<p>APR'D BY</p> <p>99/11/30</p> <p>T. Inoue</p>	<p>CHK'D BY</p> <p>99/11/30</p> <p>M Okajima</p>	<p>DRWN BY</p> <p>99/11/30</p> <p>M Okajima</p>	<p>TITLE</p> <p>ASSIST GAS</p> <p>DRWN NO. 676 001 41001, 0</p>
--	-----------------------------------	---	--	---	---

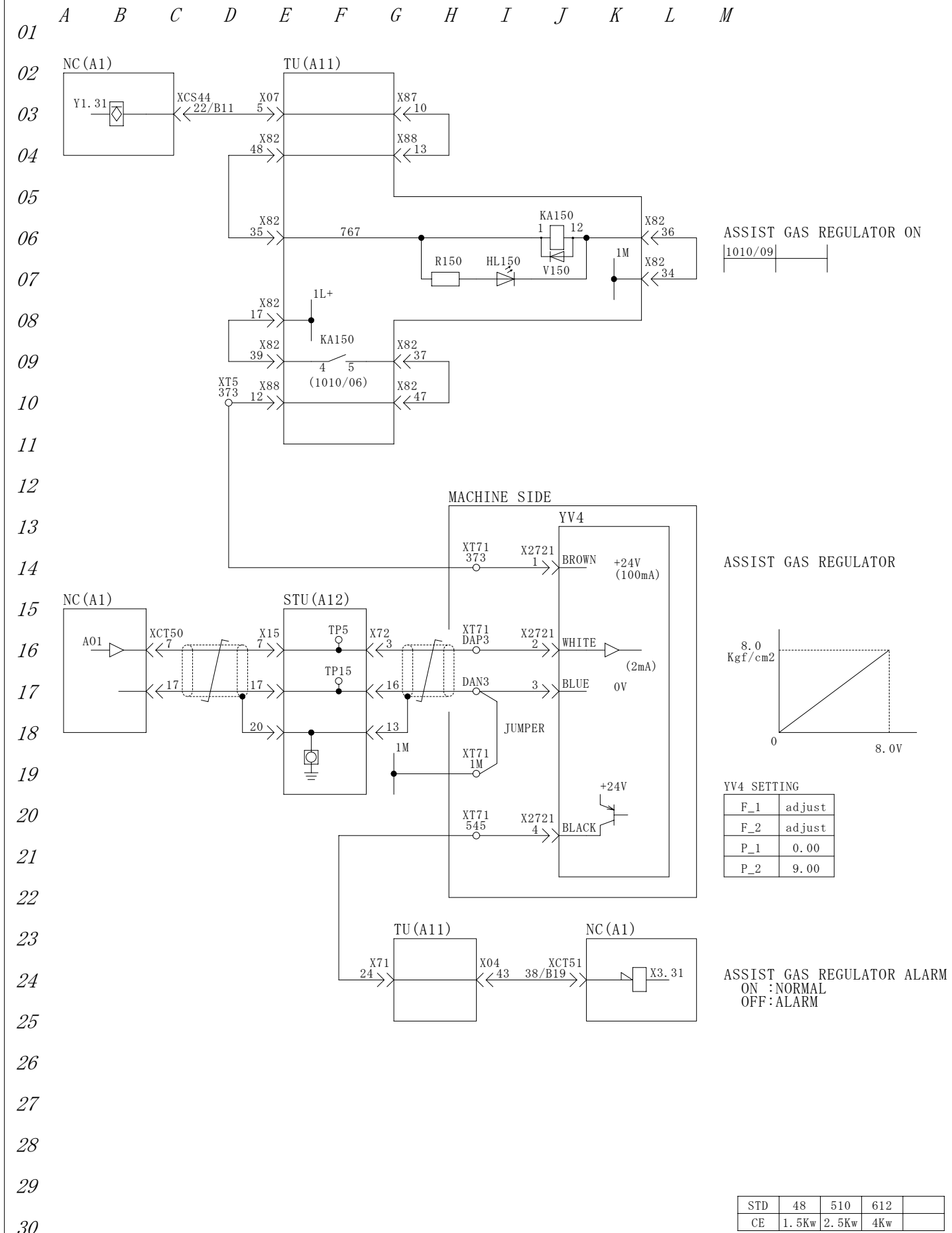

STD	48	510	612	
CE	1.5Kw	2.5Kw	4Kw	

△		 YAMAZAKI MAZAK CORPORATION	APR'D BY	CHK'D BY	DRWN BY	TITLE
△			99/11/30	99/11/30	99/11/30	ASSIST GAS REGULATOR
△			T. Inoue	M Okajima	M Okajima	
△						DRWN NO. 676 001 41010, 0
△						

This product is subject to all the applicable Japanese Foreign Exchange and Foreign Trade Law.
 本品は『外国為替及び外国貿易法』に該当しますので外国に輸出する場合には同法に基づく許可を必要とします。

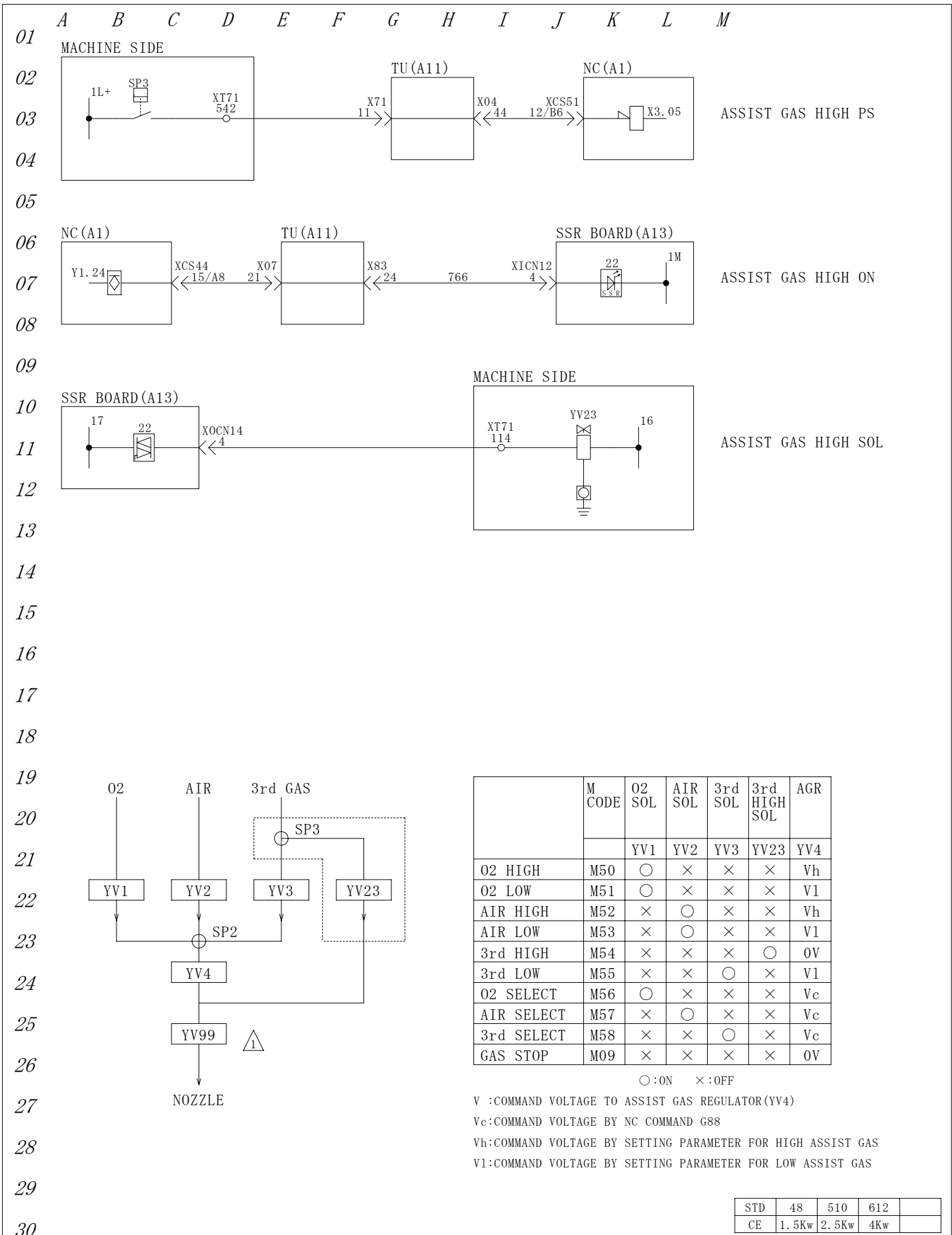

	M CODE	O2 SOL	AIR SOL	3rd SOL	3rd HIGH SOL	AGR
		YV1	YV2	YV3	YV23	YV4
O2 HIGH	M50	○	×	×	×	Vh
O2 LOW	M51	○	×	×	×	V1
AIR HIGH	M52	×	○	×	×	Vh
AIR LOW	M53	×	○	×	×	V1
3rd HIGH	M54	×	×	×	○	OV
3rd LOW	M55	×	×	○	×	V1
O2 SELECT	M56	○	×	×	×	Vc
AIR SELECT	M57	×	○	×	×	Vc
3rd SELECT	M58	×	×	○	×	Vc
GAS STOP	M09	×	×	×	×	OV

○ : ON × : OFF

V : COMMAND VOLTAGE TO ASSIST GAS REGULATOR(YV4)
 Vc:COMMAND VOLTAGE BY NC COMMAND G88
 Vh:COMMAND VOLTAGE BY SETTING PARAMETER FOR HIGH ASSIST GAS
 V1:COMMAND VOLTAGE BY SETTING PARAMETER FOR LOW ASSIST GAS

STD	48	510	612	
CE	1.5Kw	2.5Kw	4Kw	

△		 YAMAZAKI MAZAK CORPORATION	APR'D BY	CHK'D BY	DRWN BY	TITLE
△			99/11/30	99/11/30	99/11/30	ASSIST GAS HIGH PS (OPTION)
△			T. Inoue	M Okajima	M Okajima	DRWN NO. 676 001 41021, 0
△	Edition Mar. 28. '00 M. Okajima					

This product is subject to all the applicable Japanese Foreign Exchange and Foreign Trade Law.
 本品は『外国為替及び外国貿易法』に該当しますので外国に輸出する場合には同法に基づく許可を必要とします。

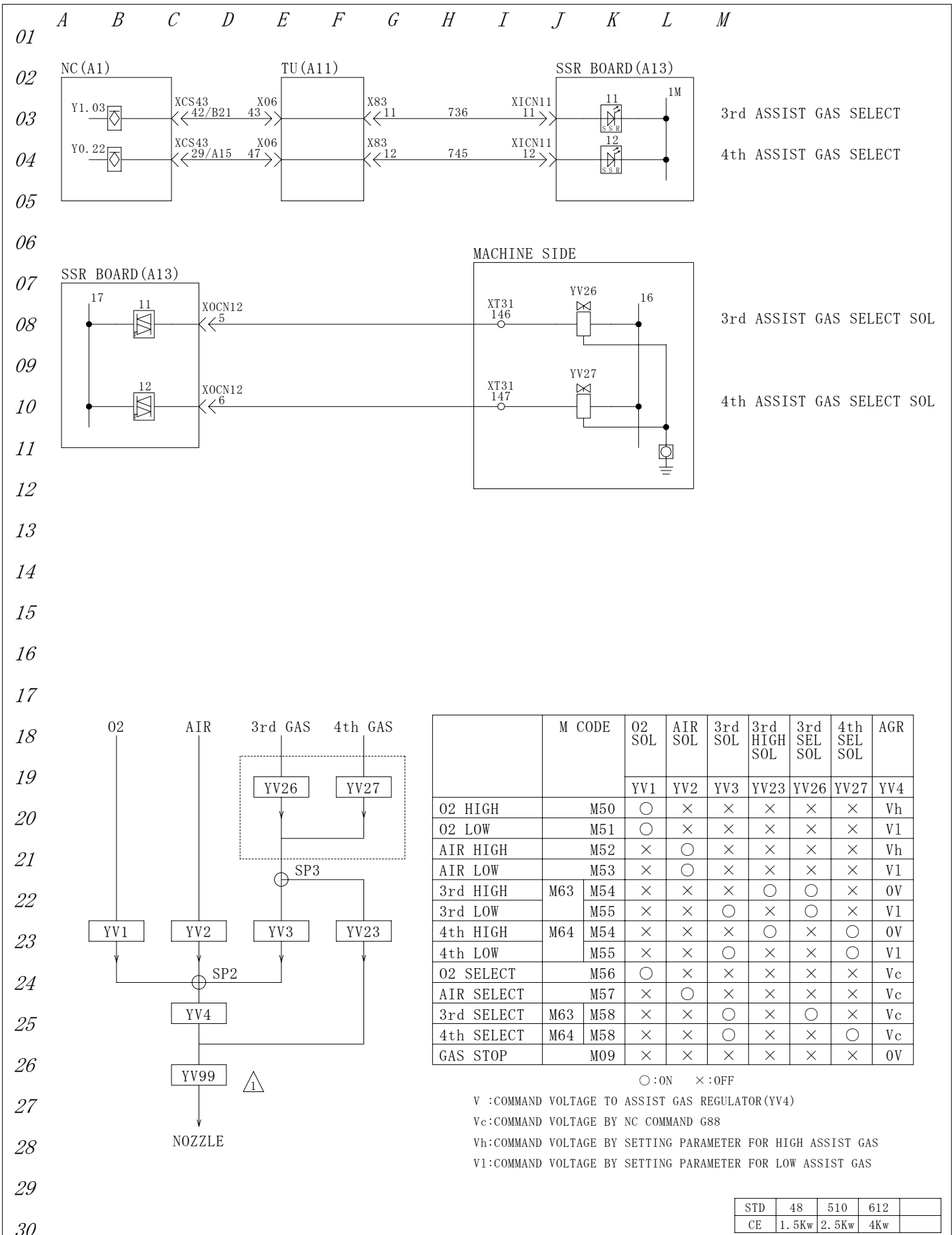

<div style="display: flex; justify-content: space-between;"> <div style="text-align: center;">  <small>YAMAZAKI MAZAK CORPORATION</small> </div> <div style="text-align: right;"> <table border="1" style="font-size: small;"> <tr> <td>APR' D BY</td> <td>CHK' D BY</td> <td>DRWN BY</td> <td>TITLE</td> </tr> <tr> <td>99/11/30</td> <td>99/11/30</td> <td>99/11/30</td> <td>4th ASSIST GAS (OPTION)</td> </tr> <tr> <td>T. Inoue</td> <td>M Okajima</td> <td>M Okajima</td> <td>DRWN NO. 676 001 41031, 0</td> </tr> </table> </div> </div>	APR' D BY	CHK' D BY	DRWN BY	TITLE	99/11/30	99/11/30	99/11/30	4th ASSIST GAS (OPTION)	T. Inoue	M Okajima	M Okajima	DRWN NO. 676 001 41031, 0	<table border="1" style="width: 100%; font-size: x-small;"> <tr> <td>STD</td> <td>48</td> <td>510</td> <td>612</td> <td></td> </tr> <tr> <td>CE</td> <td>1.5Kw</td> <td>2.5Kw</td> <td>4Kw</td> <td></td> </tr> </table>	STD	48	510	612		CE	1.5Kw	2.5Kw	4Kw	
APR' D BY	CHK' D BY	DRWN BY	TITLE																				
99/11/30	99/11/30	99/11/30	4th ASSIST GAS (OPTION)																				
T. Inoue	M Okajima	M Okajima	DRWN NO. 676 001 41031, 0																				
STD	48	510	612																				
CE	1.5Kw	2.5Kw	4Kw																				

This product is subject to all the applicable Japanese Foreign Exchange and Foreign Trade Law.
本品は『外国為替及び外国貿易法』に該当しますので外国に輸出する場合には同法に基づく許可を必要とします。

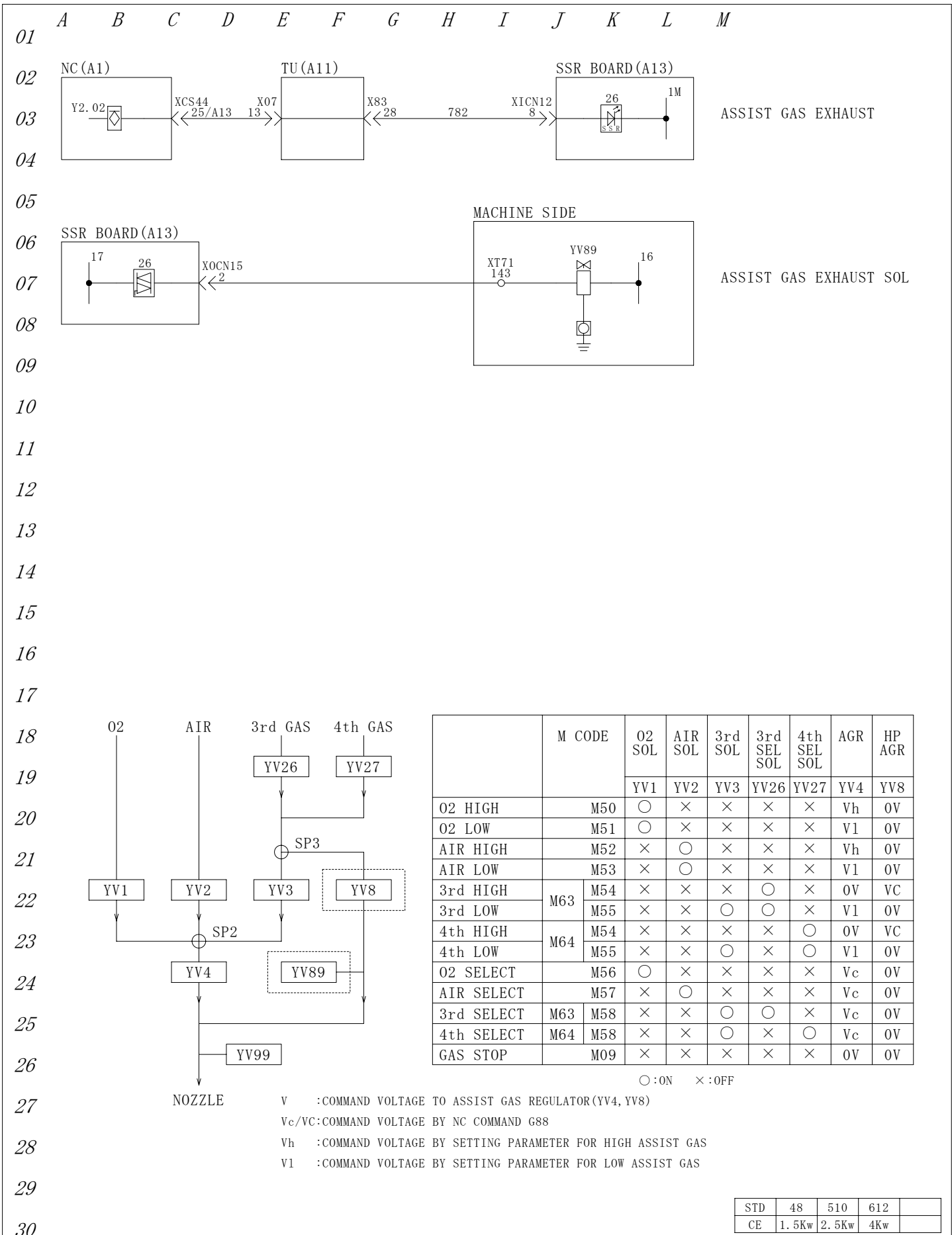

	M CODE	O2 SOL	AIR SOL	3rd SOL	3rd SEL SOL	4th SEL SOL	AGR	HP AGR
		YV1	YV2	YV3	YV26	YV27	YV4	YV8
O2 HIGH	M50	○	×	×	×	×	Vh	0V
O2 LOW	M51	○	×	×	×	×	V1	0V
AIR HIGH	M52	×	○	×	×	×	Vh	0V
AIR LOW	M53	×	○	×	×	×	V1	0V
3rd HIGH	M63	M54	×	×	×	○	×	0V
3rd LOW		M55	×	×	○	○	×	V1
4th HIGH	M64	M54	×	×	×	○	○	0V
4th LOW		M55	×	×	○	×	○	V1
O2 SELECT	M56	○	×	×	×	×	Vc	0V
AIR SELECT	M57	×	○	×	×	×	Vc	0V
3rd SELECT	M63	M58	×	×	○	○	×	Vc
4th SELECT	M64	M58	×	×	○	×	○	Vc
GAS STOP	M09	×	×	×	×	×	0V	0V

○ : ON × : OFF

V : COMMAND VOLTAGE TO ASSIST GAS REGULATOR (YV4, YV8)
 Vc/Vc: COMMAND VOLTAGE BY NC COMMAND G88
 Vh : COMMAND VOLTAGE BY SETTING PARAMETER FOR HIGH ASSIST GAS
 V1 : COMMAND VOLTAGE BY SETTING PARAMETER FOR LOW ASSIST GAS

STD	48	510	612	
CE	1.5Kw	2.5Kw	4Kw	

APR' D BY 02/02/05 T. Inoue	CHK' D BY 02/02/05 M Okaji ma	DRWN BY 02/02/05 M Okaji ma	TITLE HIGH PRESSURE ASSIST GAS REGULATOR(1) (OPTION) DRWN NO. 676 001 41050, 0
-----------------------------------	-------------------------------------	-----------------------------------	--

This product is subject to all the applicable Japanese Foreign Exchange and Foreign Trade Law.
 本品は『外国為替及び外国貿易法』に該当しますので外国に輸出する場合には同法に基づく許可を必要とします。

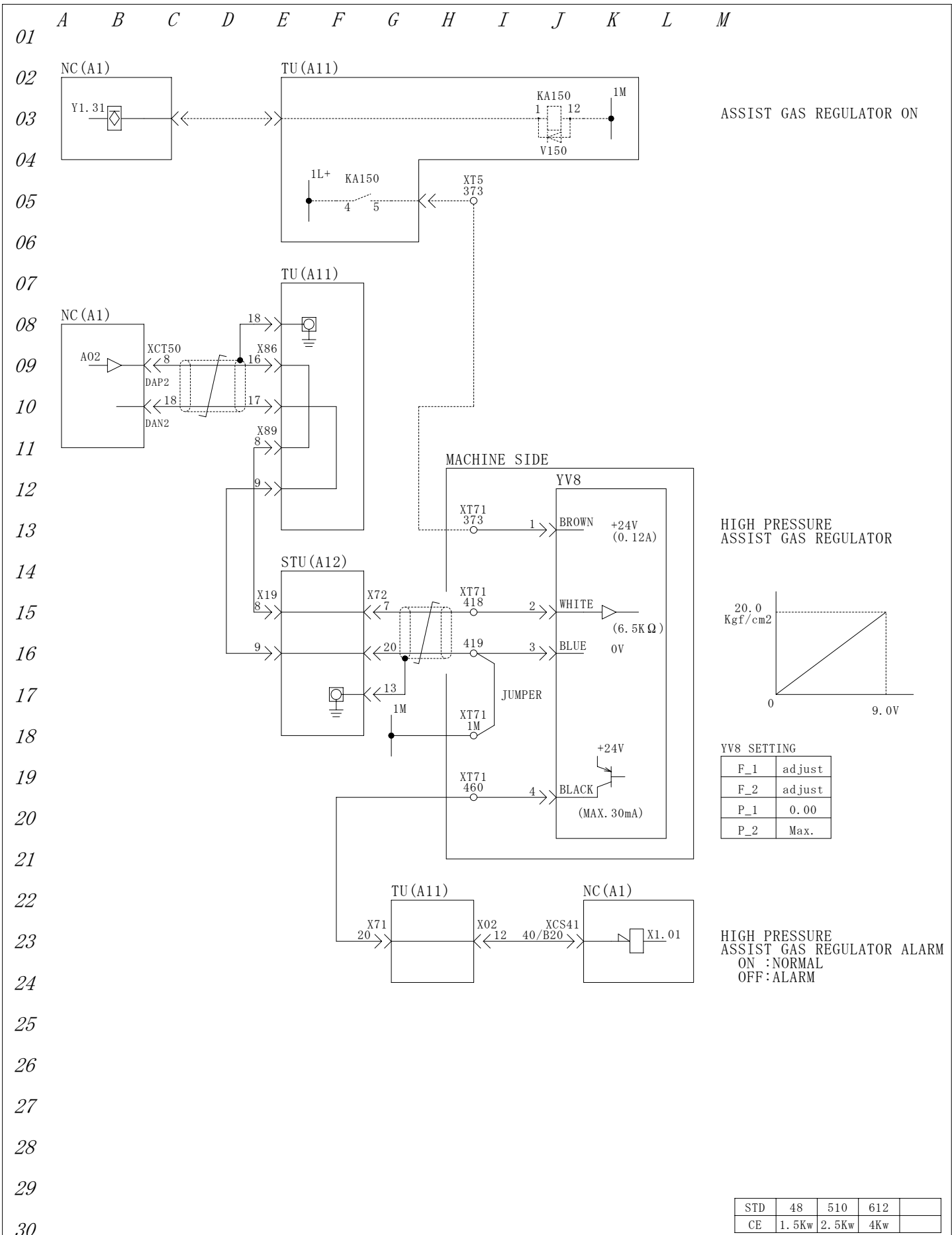

STD	48	510	612	
CE	1.5Kw	2.5Kw	4Kw	

APR'D BY	CHK'D BY	DRWN BY	TITLE
02/02/05	02/02/05	02/02/05	HIGH PRESSURE ASSIST GAS REGULATOR(2) (OPTION)
T. Inoue	M Okaji ma	M Okaji ma	DRWN NO. 676 001 41060, 0



This product is subject to all the applicable Japanese Foreign Exchange and Foreign Trade Law.
 本品は『外国為替及び外国貿易法』に該当しますので外国に輸出する場合には同法に基づく許可を必要とします。

01
02
03
04
05
06
07
08
09
10
11
12
13
14
15
16
17
18
19
20
21
22
23
24
25
26
27
28
29
30

OPERATING PANEL

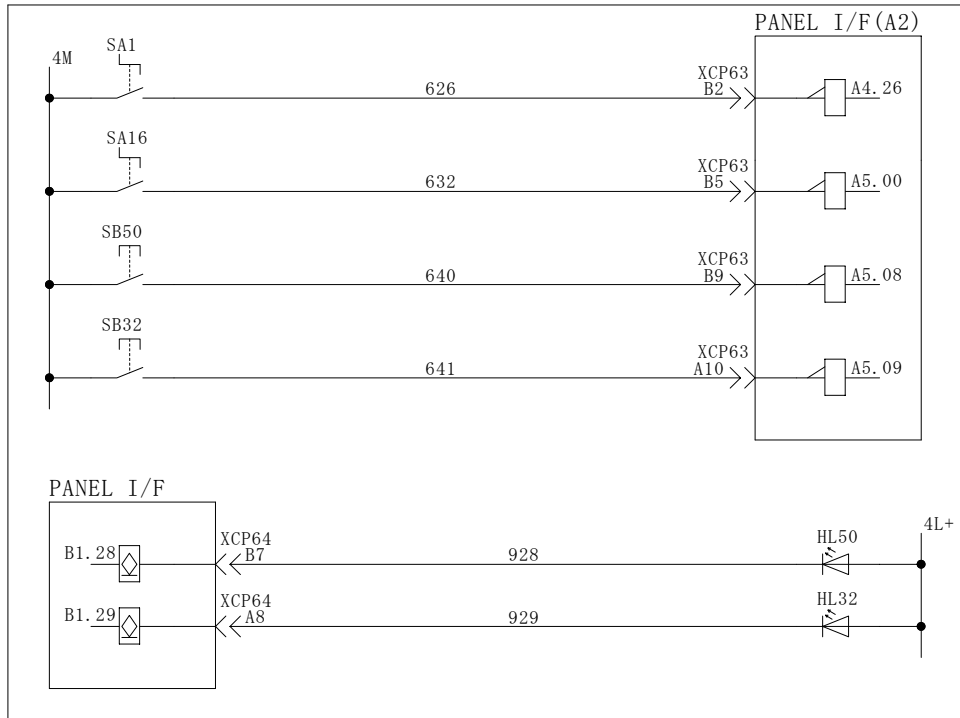

△
STYLUS UP SS
(POTENTIOMETER TYPE ONLY)

△
NON CONTACT SENSOR SS
(NON CONTACT TYPE ONLY)

RETRACE PB

NC RETRY PB
(OPTION)

RETRACE LED

NC RETRY LED
(OPTION)



POTENTIOMETER ONLY

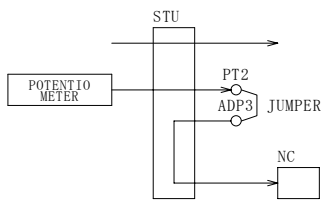

NON CONTACT SENSOR ONLY

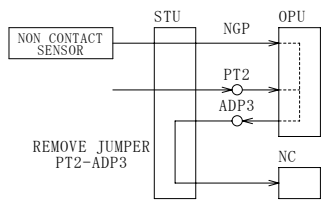

POTENTIOMETER AND NON CONTACT

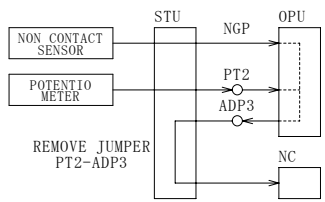

STD	48	510	612	
CE	1.5Kw	2.5Kw	4Kw	

△		 YAMAZAKI MAZAK CORPORATION	APR'D BY	CHK'D BY	DRWN BY	TITLE
△			99/11/30	99/11/30	99/11/30	GAP SENSOR SWITCH
△			T. Inoue	M Okajima	M Okajima	
△			Edition Aug. 07. '01 M. Okajima			

This product is subject to all the applicable Japanese Foreign Exchange and Foreign Trade Law.
 本品は『外国為替及び外国貿易法』に該当しますので外国に輸出する場合には同法に基づく許可を必要とします。

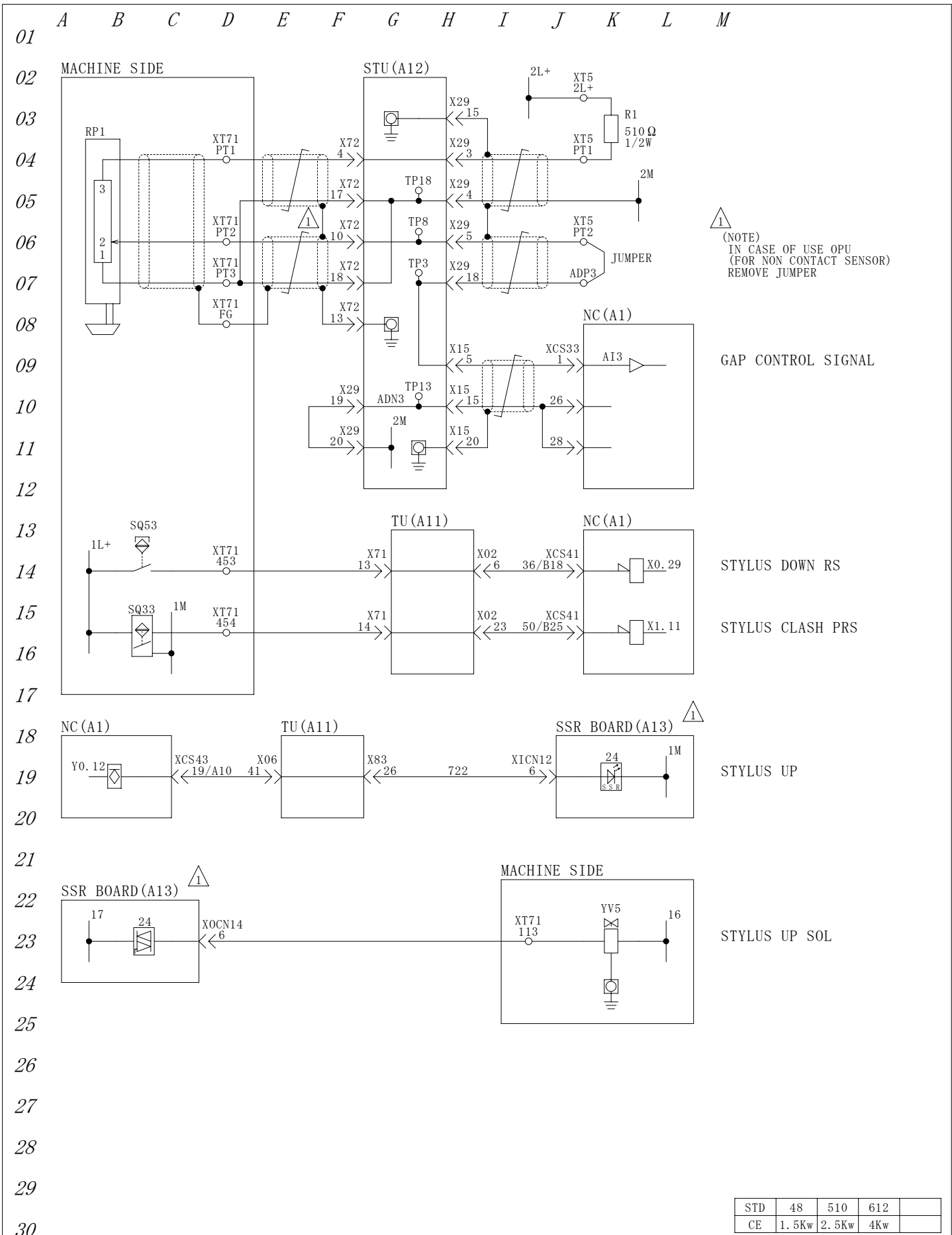

STD	48	510	612	
CE	1.5Kw	2.5Kw	4Kw	

APR'D BY	CHK'D BY	DRWN BY	TITLE
99/11/30	99/11/30	99/11/30	POTENTIOMETER GAP SENSOR
T. Inoue	M Okajima	M Okajima	DRWN NO. 676 001 41111, 0

This product is subject to all the applicable Japanese Foreign Exchange and Foreign Trade Law.
 本品は『外国為替及び外国貿易法』に該当しますので外国に輸出する場合には同法に基づく許可を必要とします。

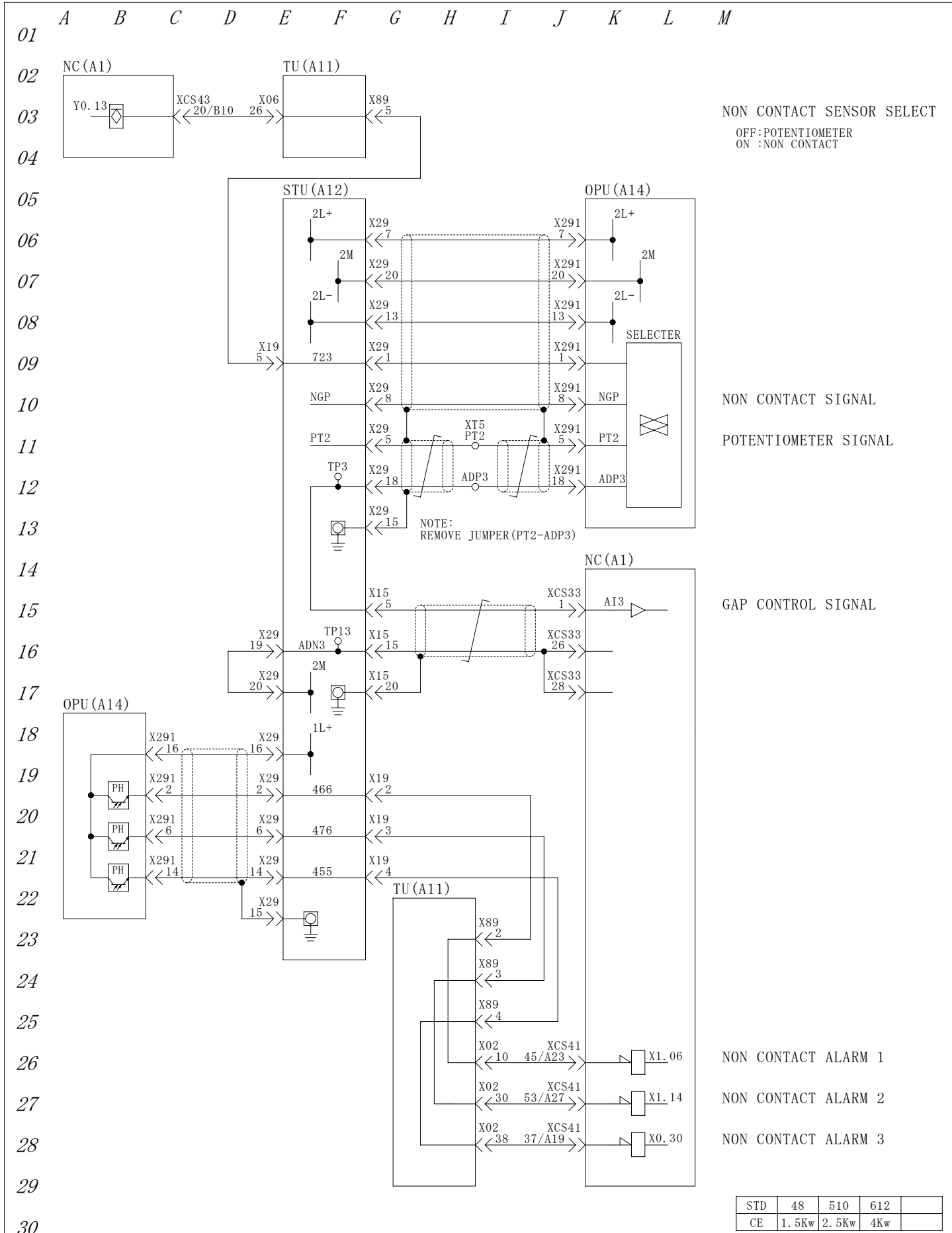

STD	48	510	612	
CE	1.5Kw	2.5Kw	4Kw	

△		 YAMAZAKI MAZAK CORPORATION	APR'D BY	CHK'D BY	DRWN BY	TITLE
△			99/11/30	99/11/30	99/11/30	NON CONTACT GAP SENSOR (OPTION)
△			T. Inoue	M Okaji ma	M Okaji ma	DRWN NO. 676 001 41150, 0
△						
△						

This product is subject to all the applicable Japanese Foreign Exchange and Foreign Trade Law.
 本品は『外国為替及び外国貿易法』に該当しますので外国に輸出する場合には同法に基づく許可を必要とします。

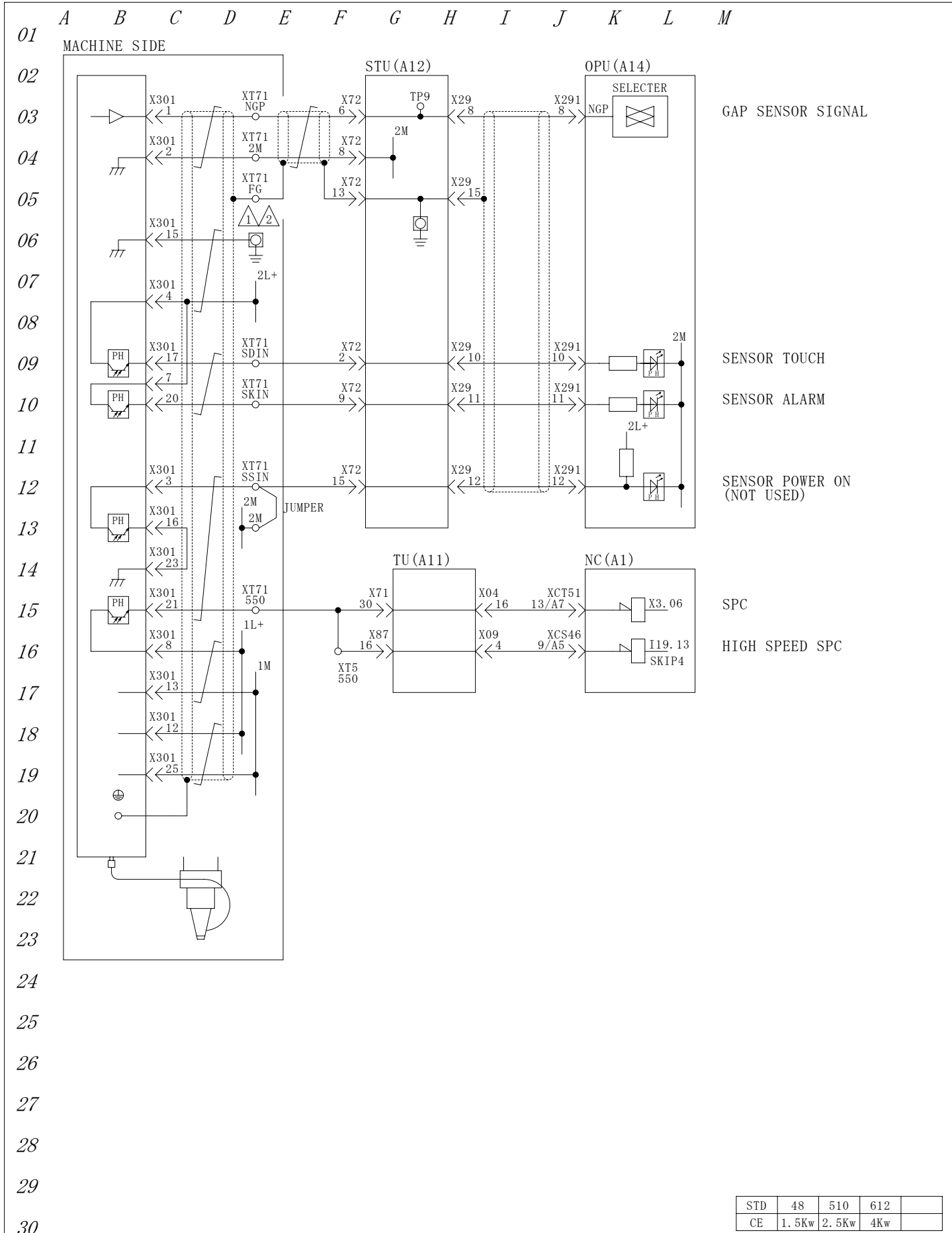

STD	48	510	612	
CE	1.5Kw	2.5Kw	4Kw	

		 YAMAZAKI MAZAK CORPORATION	APR'D BY	CHK'D BY	DRWN BY	TITLE
			T. Inoue	M Okajima	M Okajima	NON CONTACT GAP SENSOR MAZAK TYPE(OPTION)
	Edition Jul.26.'01 M.Okajima Edition Aug.10.'00 M.Okajima					DRWN NO. 676 001 41162.0

This product is subject to all the applicable Japanese Foreign Exchange and Foreign Trade Law.
 本品は『外国為替及び外国貿易法』に該当しますので外国に輸出する場合には同法に基づく許可を必要とします。

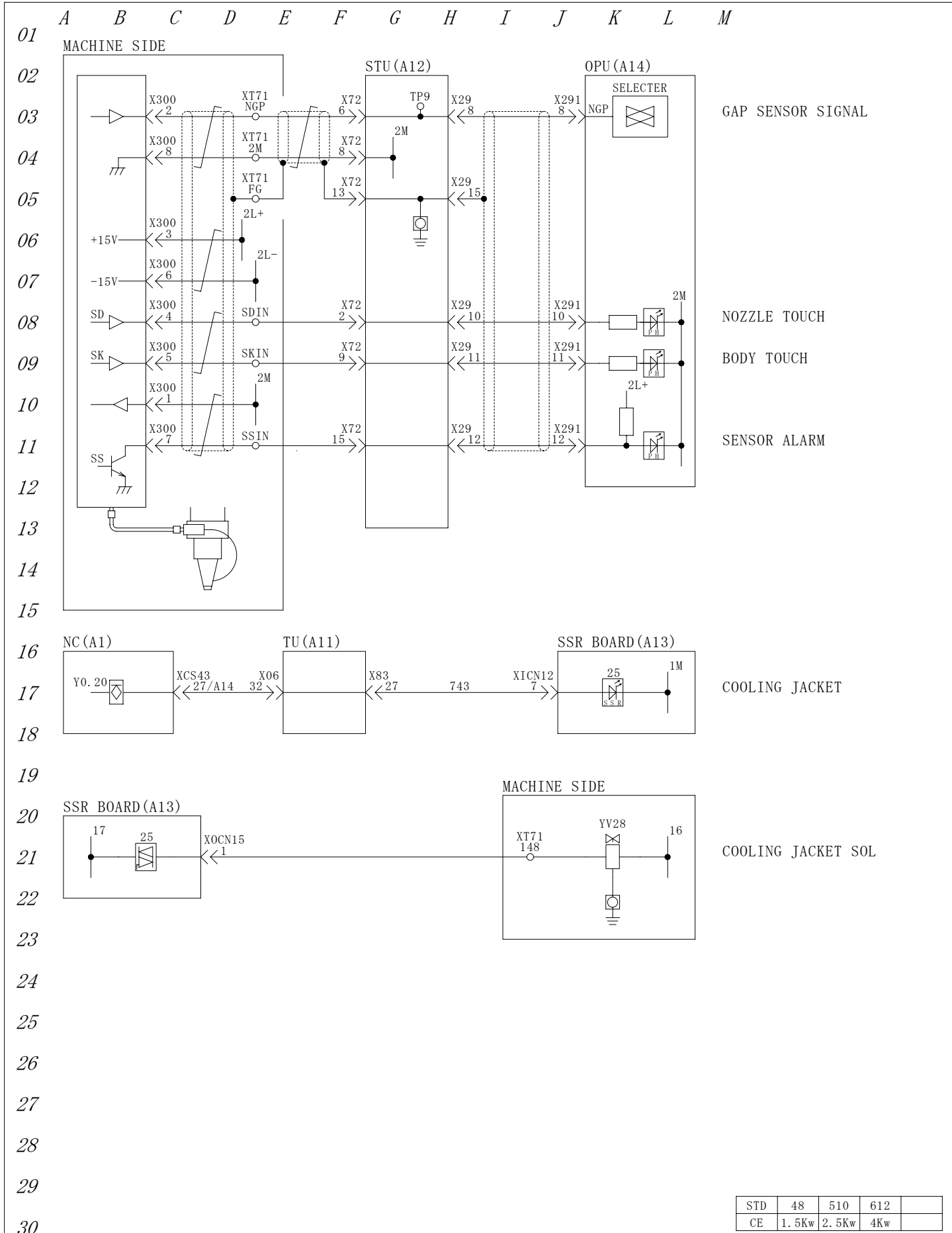

STD	48	510	612	
CE	1.5Kw	2.5Kw	4Kw	

△		 YAMAZAKI MAZAK CORPORATION	APR'D BY	CHK'D BY	DRWN BY	TITLE
△			99/11/30	99/11/30	99/11/30	NON CONTACT GAP SENSOR WEIDMULLER TYPE (NOT USED)
△			T. Inoue	M Okajima	M Okajima	DRWN NO. 676 001 41200, 0
△						
△						

This product is subject to all the applicable Japanese Foreign Exchange and Foreign Trade Law.
 本品は『外国為替及び外国貿易法』に該当しますので外国に輸出する場合には同法に基づく許可を必要とします。

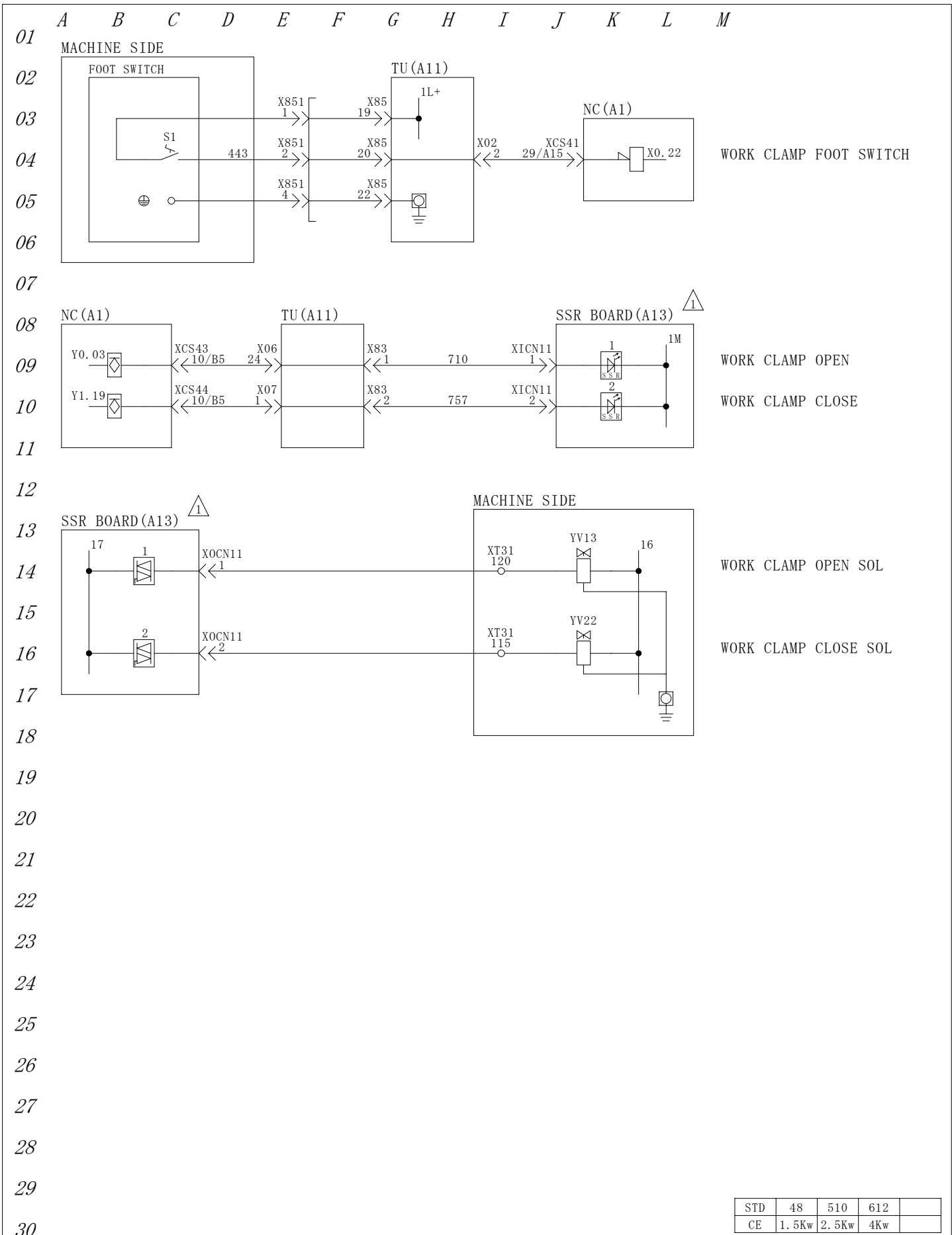

STD	48	510	612	
CE	1.5Kw	2.5Kw	4Kw	

△		 YAMAZAKI MAZAK CORPORATION	APR'D BY	CHK'D BY	DRWN BY	TITLE
△			99/11/30	99/11/30	99/11/30	WORK CLAMP
△			T. Inoue	M Okajima	M Okajima	
△	Edition Jul.26.'01 M.Okajima					DRWN NO. 676 001 41301,0

This product is subject to all the applicable Japanese Foreign Exchange and Foreign Trade Law.
 本品は『外国為替及び外国貿易法』に該当しますので外国に輸出する場合には同法に基づく許可を必要とします。

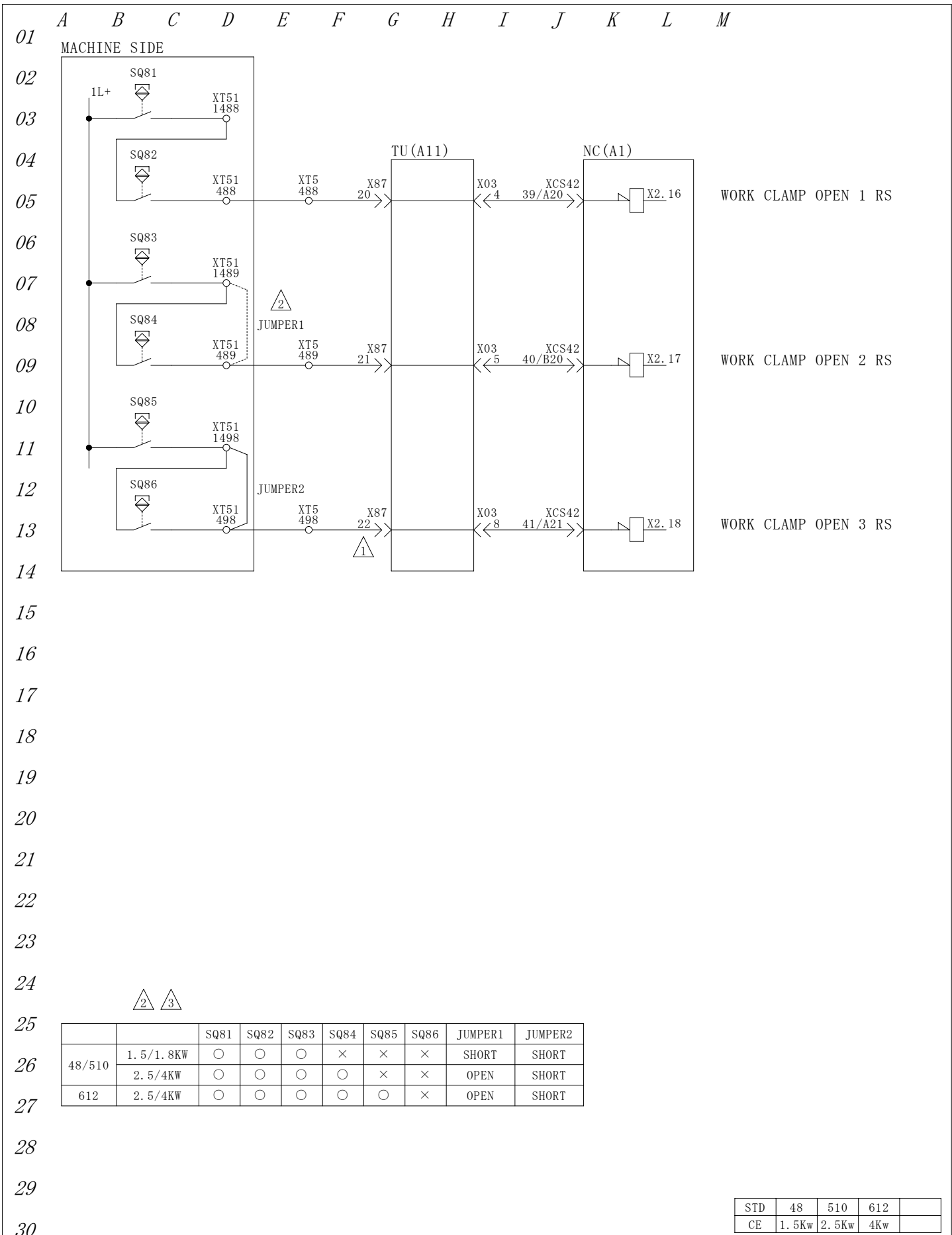

		SQ81	SQ82	SQ83	SQ84	SQ85	SQ86	JUMPER1	JUMPER2
48/510	1.5/1.8KW	○	○	○	×	×	×	SHORT	SHORT
	2.5/4KW	○	○	○	○	×	×	OPEN	SHORT
612	2.5/4KW	○	○	○	○	○	×	OPEN	SHORT

STD	48	510	612	
CE	1.5Kw	2.5Kw	4Kw	

△		APR'D BY	CHK'D BY	DRWN BY	TITLE
△		99/11/30	99/11/30	99/11/30	WORK CLAMP SENSOR (OPTION)
△	Edition Jul.05.'01 M.Okajima	Mazak YAMAZAKI MAZAK CORPORATION	T. Inoue	M Okajima	M Okajima
△	Edition Aug.24.'00 M.Okajima				
△	Edition Mar.27.'00 M.Okajima				
					DRWN NO. 676 001 41323,0

This product is subject to all the applicable Japanese Foreign Exchange and Foreign Trade Law.
 本品は『外国為替及び外国貿易法』に該当しますので外国に輸出する場合には同法に基づく許可を必要とします。

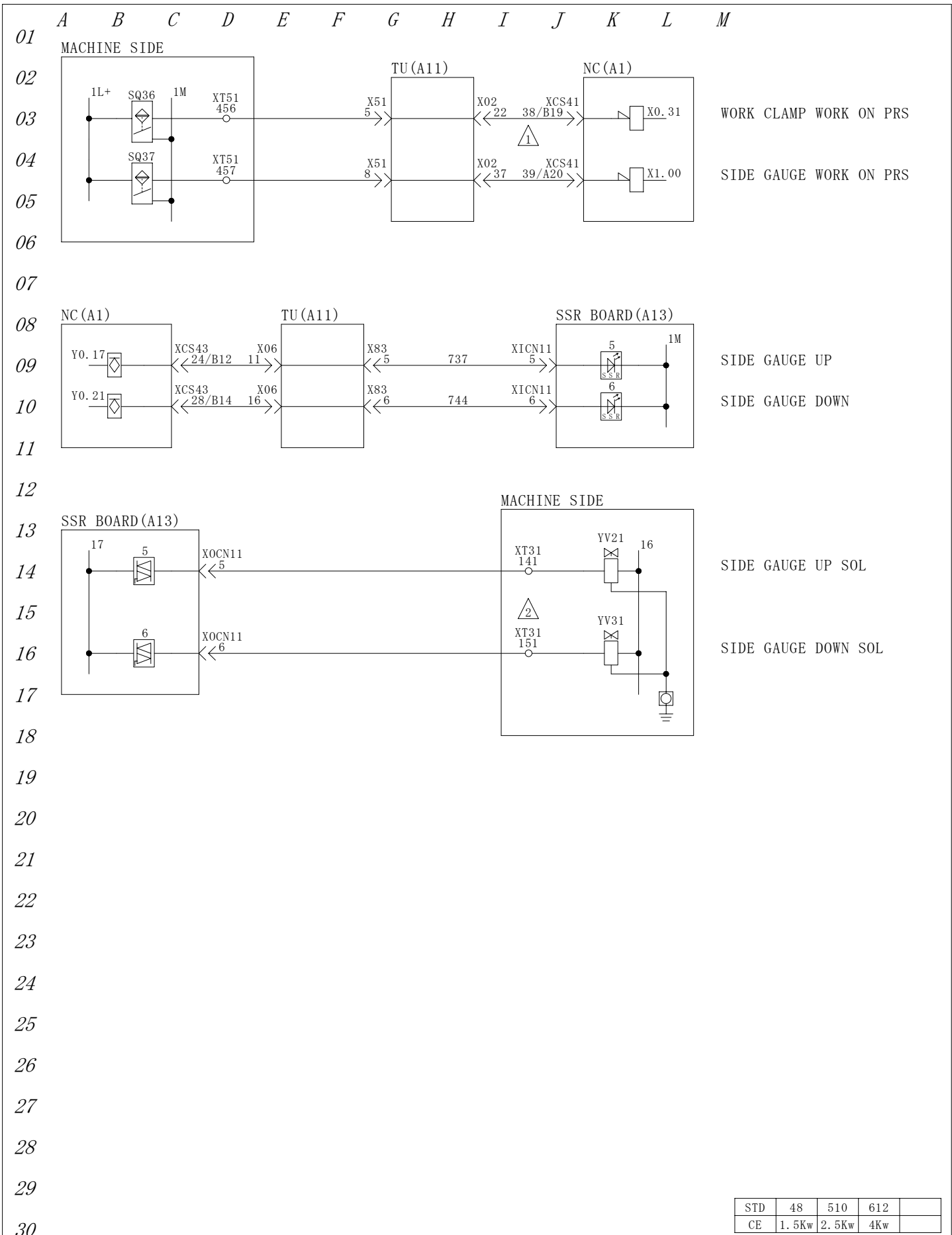

STD	48	510	612	
CE	1.5Kw	2.5Kw	4Kw	

△		 YAMAZAKI MAZAK CORPORATION	APR' D BY	CHK' D BY	DRWN BY	TITLE
△			99/11/30	99/11/30	99/11/30	WORK ON SENSOR (OPTION)
△			T. Inoue	M Okajima	M Okajima	DRWN NO.
△	Edition Jun.03.'04 M.Okajima					676 001 41332, 0
△	Edition Mar.27.'00 M.Okajima					

This product is subject to all the applicable Japanese Foreign Exchange and Foreign Trade Law.
 本品は『外国為替及び外国貿易法』に該当しますので外国に輸出する場合には同法に基づく許可を必要とします。

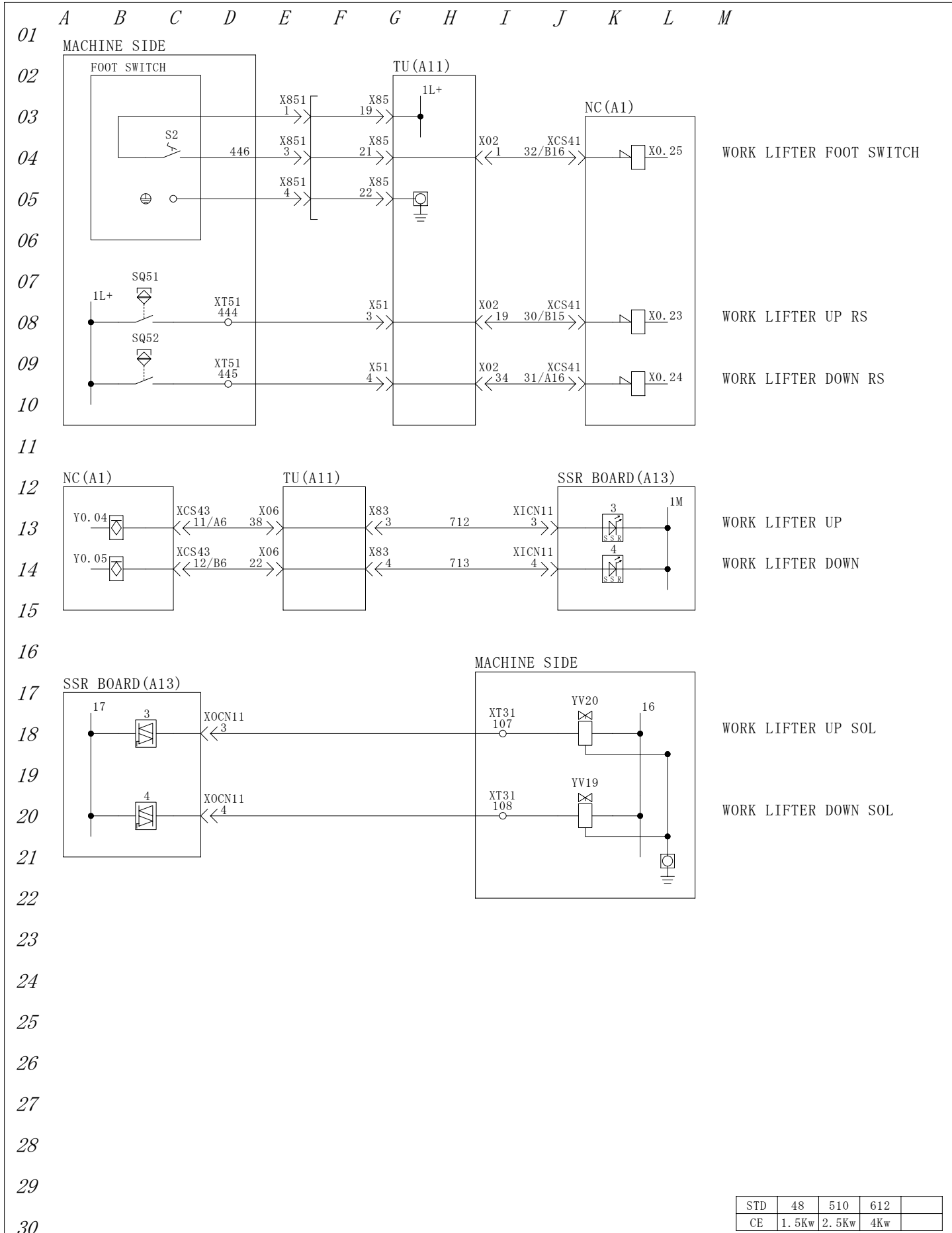

STD	48	510	612	
CE	1.5Kw	2.5Kw	4Kw	

	APR'D BY	CHK'D BY	DRWN BY	TITLE
	99/11/30	99/11/30	99/11/30	WORK LIFTER
	T. Inoue	M Okajima	M Okajima	DRWN NO. 676 001 41350, 0

This product is subject to all the applicable Japanese Foreign Exchange and Foreign Trade Law.
 本品は『外国為替及び外国貿易法』に該当しますので外国に輸出する場合には同法に基づく許可を必要とします。

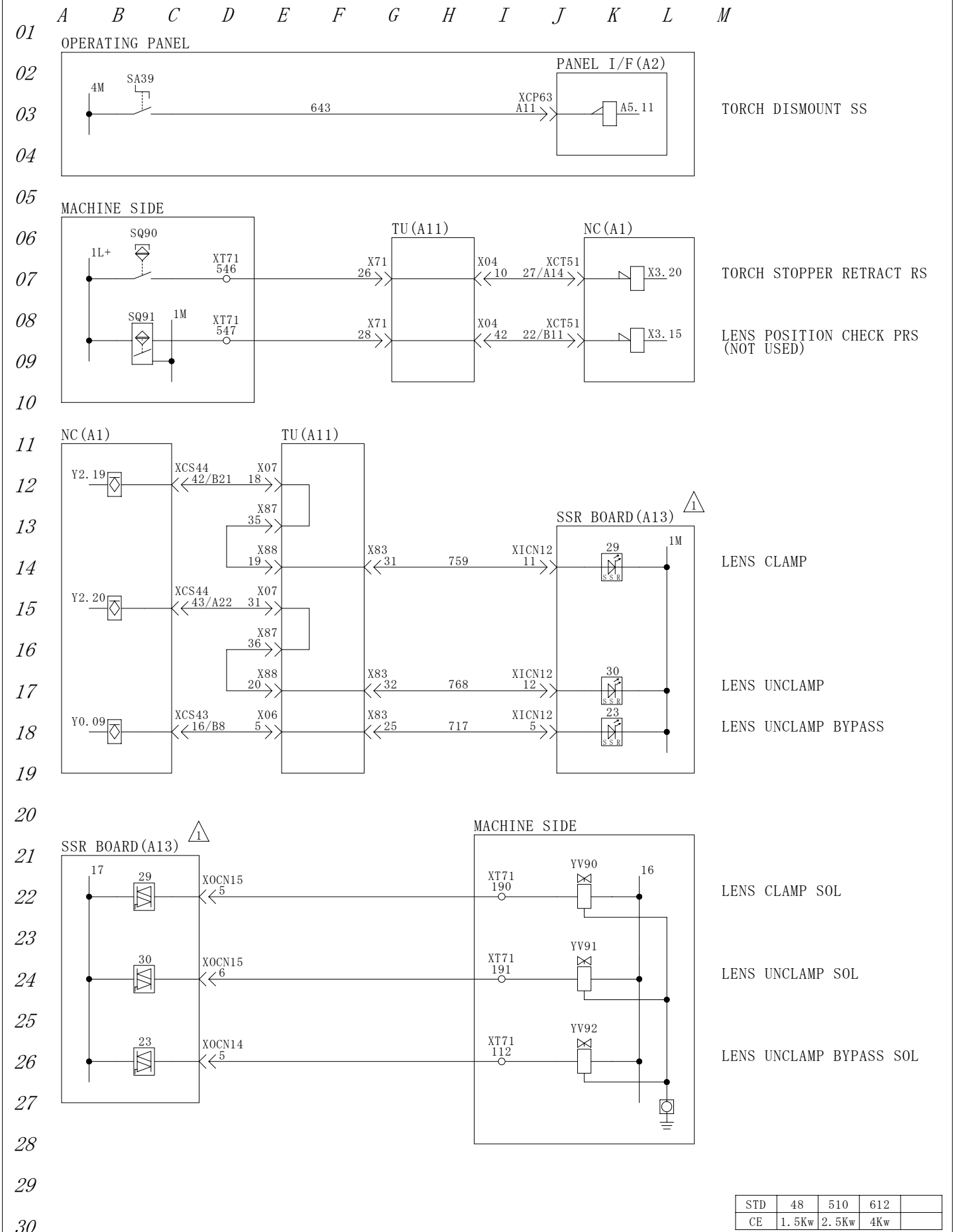

STD	48	510	612	
CE	1.5Kw	2.5Kw	4Kw	

APR' D BY 99/11/30 T. Inoue	CHK' D BY 99/11/30 M Okajima	DRWN BY 99/11/30 M Okajima	TITLE PROGRAMMABLE FOCUS (OPTION) DRWN NO. 676 001 41401, 0
-----------------------------------	------------------------------------	----------------------------------	--



This product is subject to all the applicable Japanese Foreign Exchange and Foreign Trade Law.
 本品は『外国為替及び外国貿易法』に該当しますので外国に輸出する場合には同法に基づく許可を必要とします。

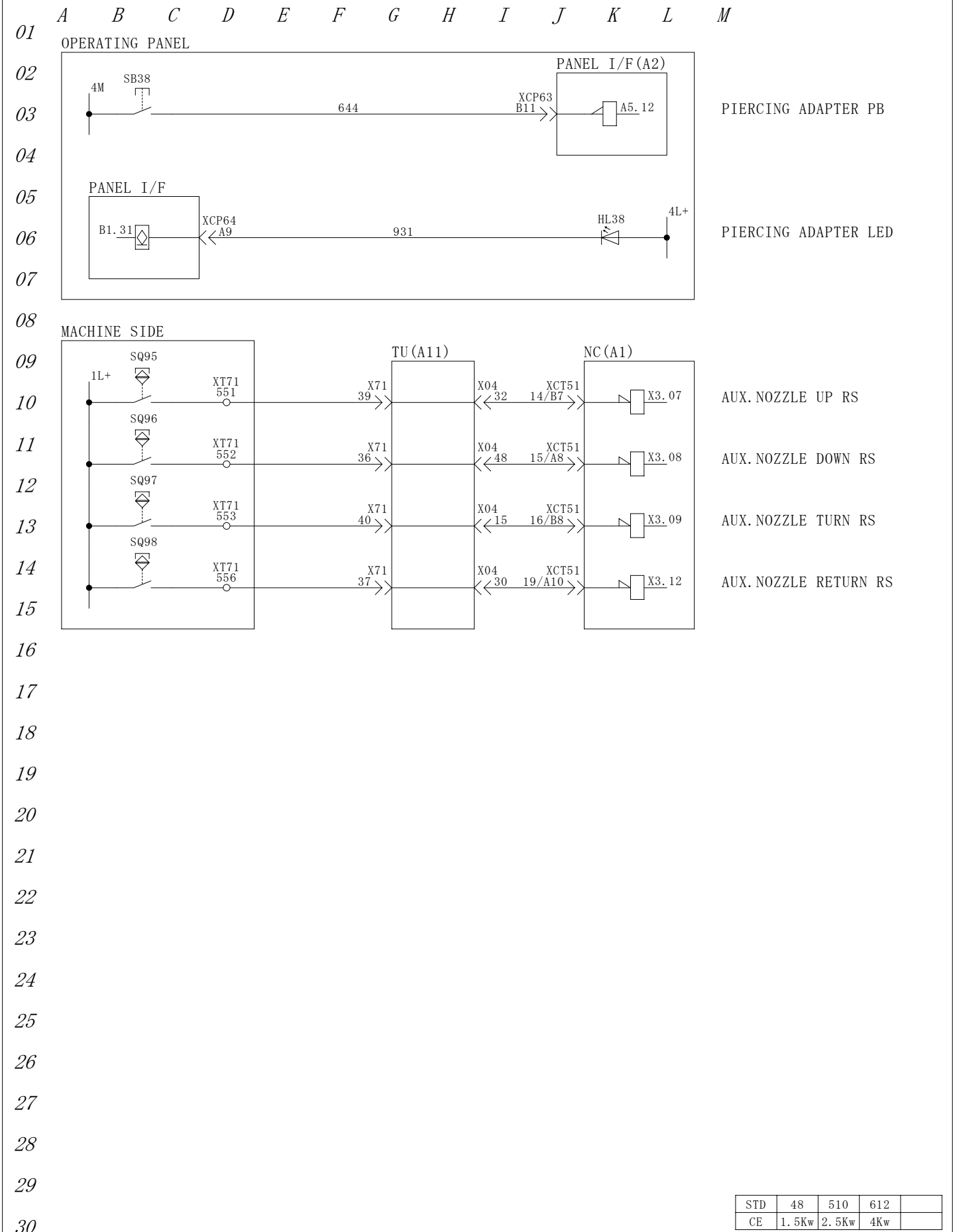

STD	48	510	612	
CE	1.5Kw	2.5Kw	4Kw	

APR' D BY 99/11/30 T. Inoue	CHK' D BY 99/11/30 M Okaji ma	DRWN BY 99/11/30 M Okaji ma	TITLE PIERCING ADAPTER(1) (OPTION) DRWN NO. 676 001 41450, 0
-----------------------------------	-------------------------------------	-----------------------------------	---



This product is subject to all the applicable Japanese Foreign Exchange and Foreign Trade Law.
 本品は『外国為替及び外国貿易法』に該当しますので外国に輸出する場合には同法に基づく許可を必要とします。

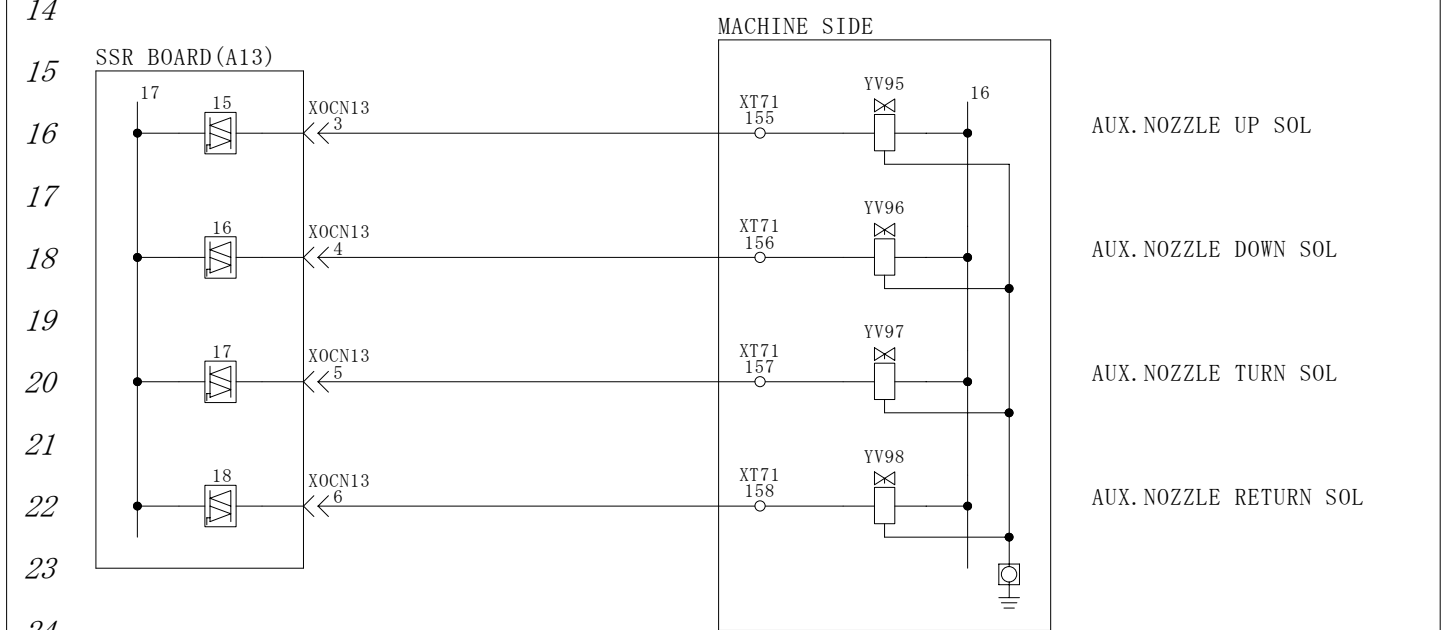
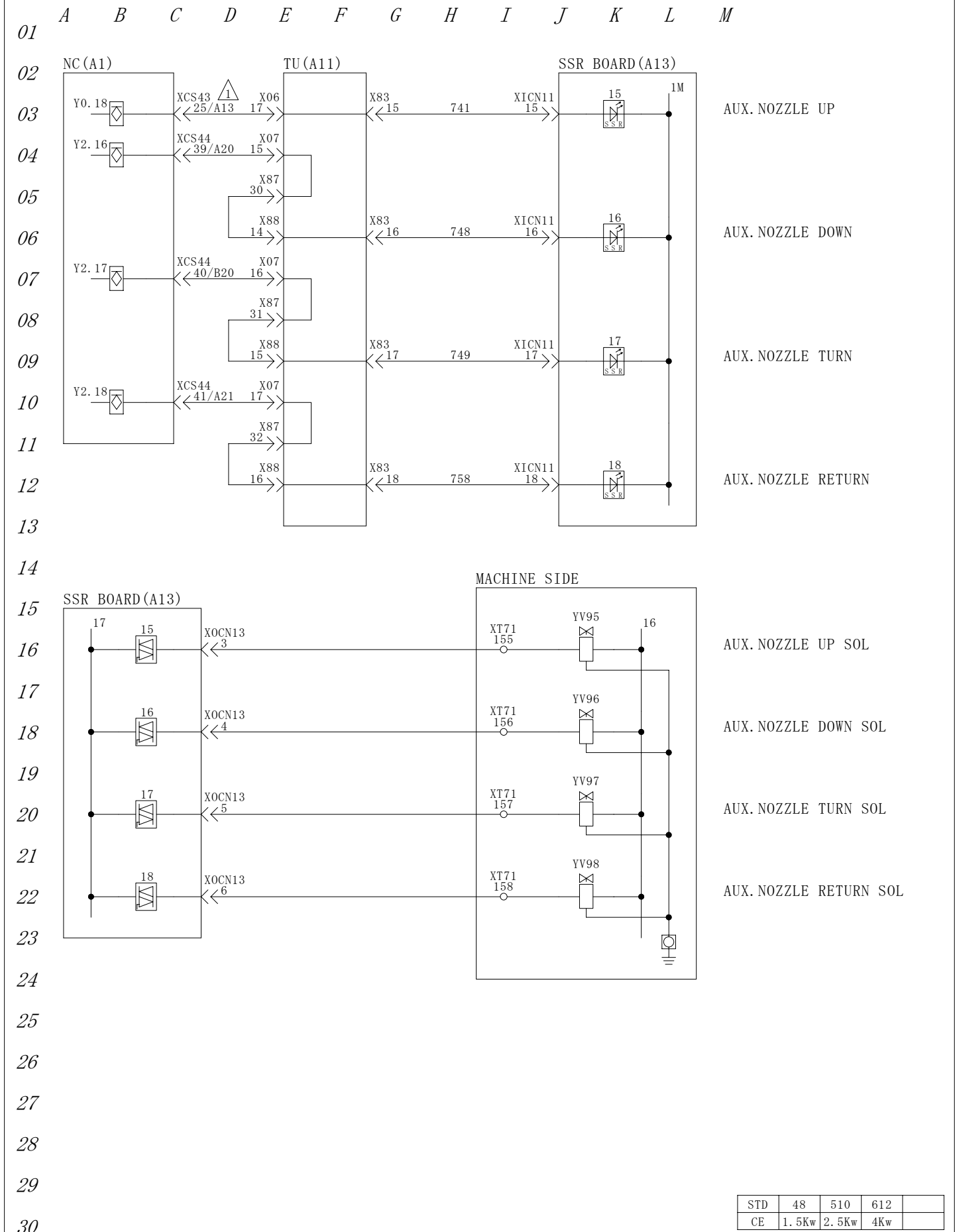

STD	48	510	612	
CE	1.5Kw	2.5Kw	4Kw	

△		 YAMAZAKI MAZAK CORPORATION	APR' D BY	CHK' D BY	DRWN BY	TITLE
△			99/11/30	99/11/30	99/11/30	PIERCING ADAPTER (2) (OPTION)
△			T. Inoue	M Okaji ma	M Okaji ma	DRWN NO.
△			676 001 41461, 0			

This product is subject to all the applicable Japanese Foreign Exchange and Foreign Trade Law.
 本品は『外国為替及び外国貿易法』に該当しますので外国に輸出する場合には同法に基づく許可を必要とします。

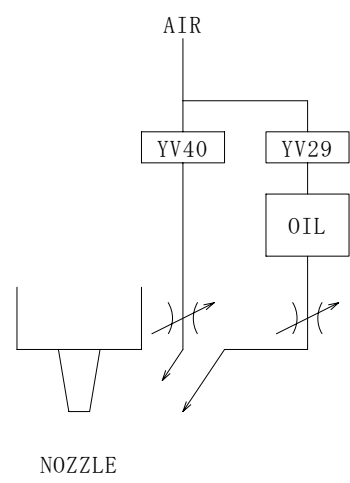
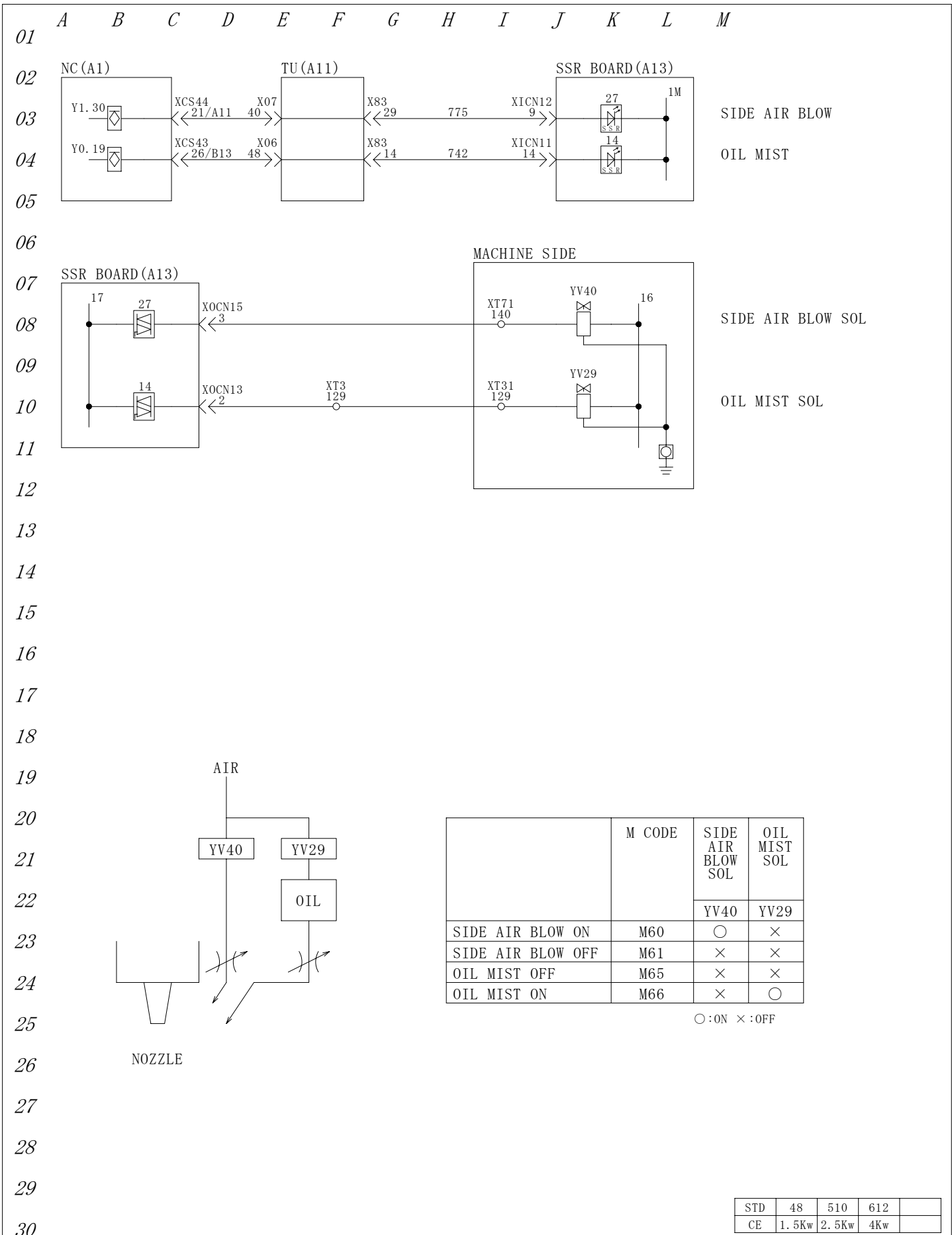

	M CODE	SIDE AIR BLOW SOL	OIL MIST SOL
		YV40	YV29
SIDE AIR BLOW ON	M60	○	×
SIDE AIR BLOW OFF	M61	×	×
OIL MIST OFF	M65	×	×
OIL MIST ON	M66	×	○

○:ON ×:OFF

STD	48	510	612	
CE	1.5Kw	2.5Kw	4Kw	

APR'D BY 99/11/30 T. Inoue	CHK'D BY 99/11/30 M Okaji ma	DRWN BY 99/11/30 M Okaji ma	TITLE SIDE BLOW (OPTION) DRWN NO. 676 001 41500, 0
----------------------------------	------------------------------------	-----------------------------------	--



This product is subject to all the applicable Japanese Foreign Exchange and Foreign Trade Law.
 本品は『外国為替及び外国貿易法』に該当しますので外国に輸出する場合には同法に基づく許可を必要とします。

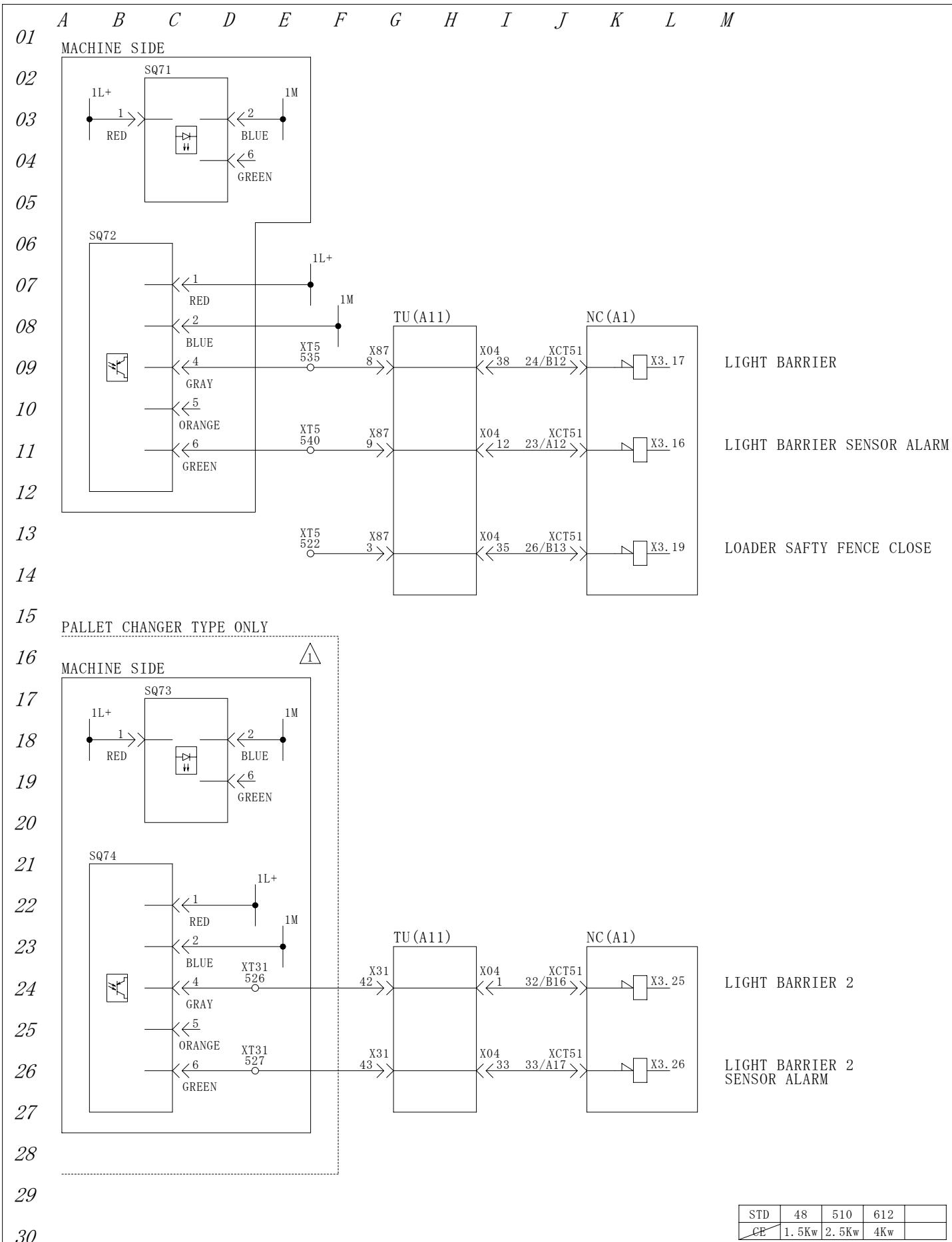

STD	48	510	612	
CE	1.5Kw	2.5Kw	4Kw	

△		 YAMAZAKI MAZAK CORPORATION	APR'D BY	CHK'D BY	DRWN BY	TITLE
△			99/11/30	99/11/30	99/11/30	LIGHT BARRIER
△			T. Inoue	M Okajima	M Okajima	
△			DRWN NO. 676 001 41601, 0			

This product is subject to all the applicable Japanese Foreign Exchange and Foreign Trade Law.
 本品は『外国為替及び外国貿易法』に該当しますので外国に輸出する場合には同法に基づく許可を必要とします。

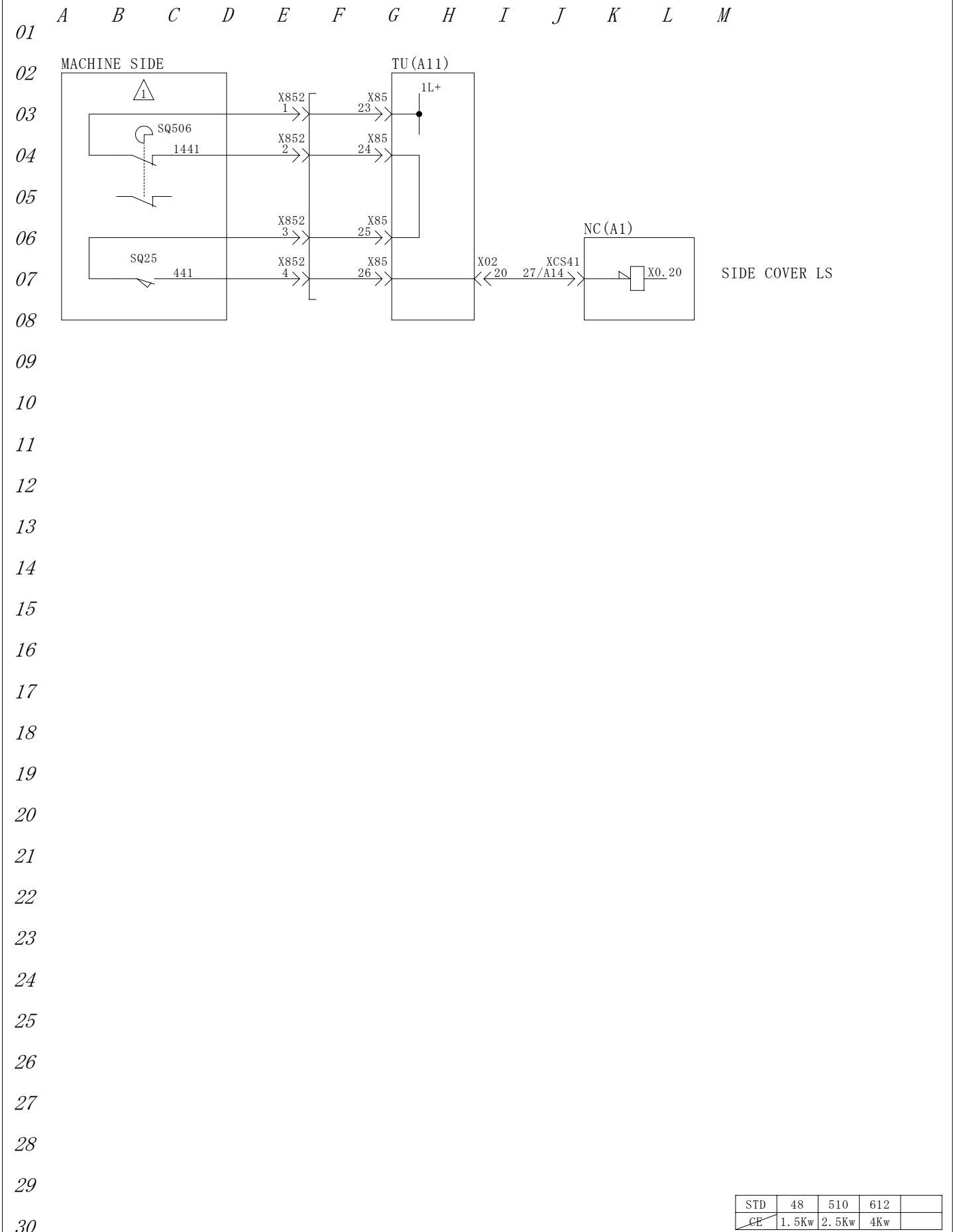

STD	48	510	612	
CE	1.5Kw	2.5Kw	4Kw	

△		 YAMAZAKI MAZAK CORPORATION	APR'D BY	CHK'D BY	DRWN BY	TITLE
△			99/11/30	99/11/30	99/11/30	SIDE COVER
△			T. Inoue	M Okajima	M Okajima	DRWN NO.
△	Edition May.12.'00 M.Okajima					676 001 41701, 0

This product is subject to all the applicable Japanese Foreign Exchange and Foreign Trade Law.
 本品は『外国為替及び外国貿易法』に該当しますので外国に輸出する場合には同法に基づく許可を必要とします。

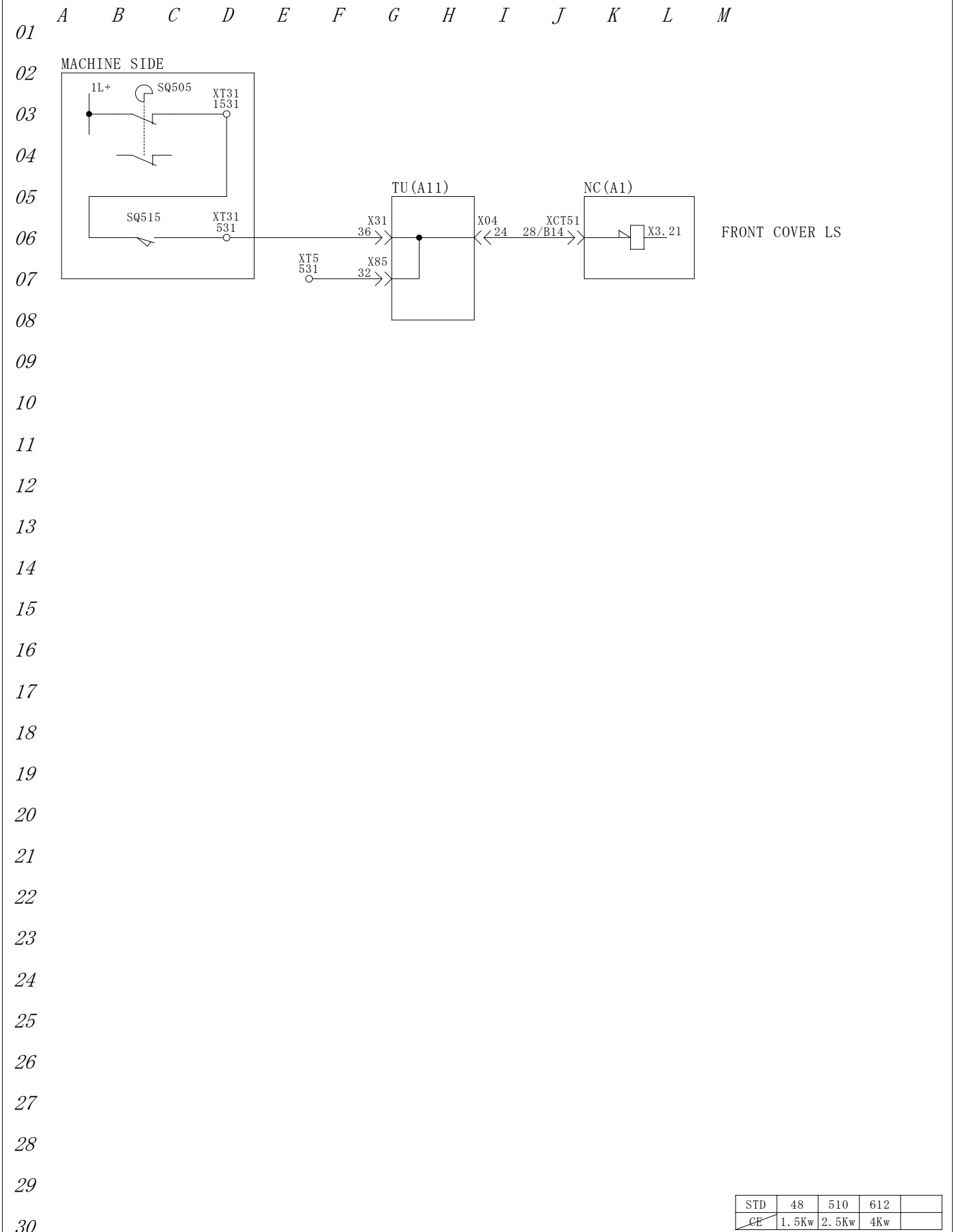

STD	48	510	612	
CE	1.5Kw	2.5Kw	4Kw	

	 <small>YAMAZAKI MAZAK CORPORATION</small>	APR'D BY	CHK'D BY	DRWN BY	TITLE
		99/11/30	99/11/30	99/11/30	FRONT COVER
		T. Inoue	M Okajima	M Okajima	DRWN NO. 676 001 41750, 0

This product is subject to all the applicable Japanese Foreign Exchange and Foreign Trade Law.
 本品は『外国為替及び外国貿易法』に該当しますので外国に輸出する場合には同法に基づく許可を必要とします。

01 OPERATING PANEL

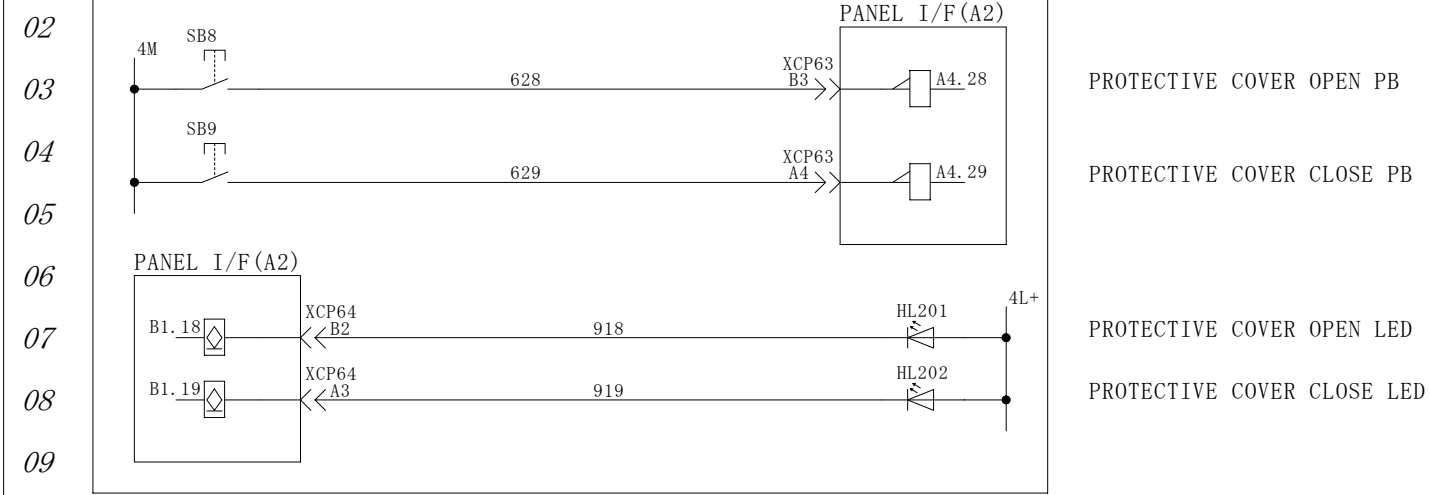

02

03 PROTECTIVE COVER OPEN PB

04 PROTECTIVE COVER CLOSE PB

05

06

07 PROTECTIVE COVER OPEN LED

08 PROTECTIVE COVER CLOSE LED

09

10

11 MACHINE SIDE

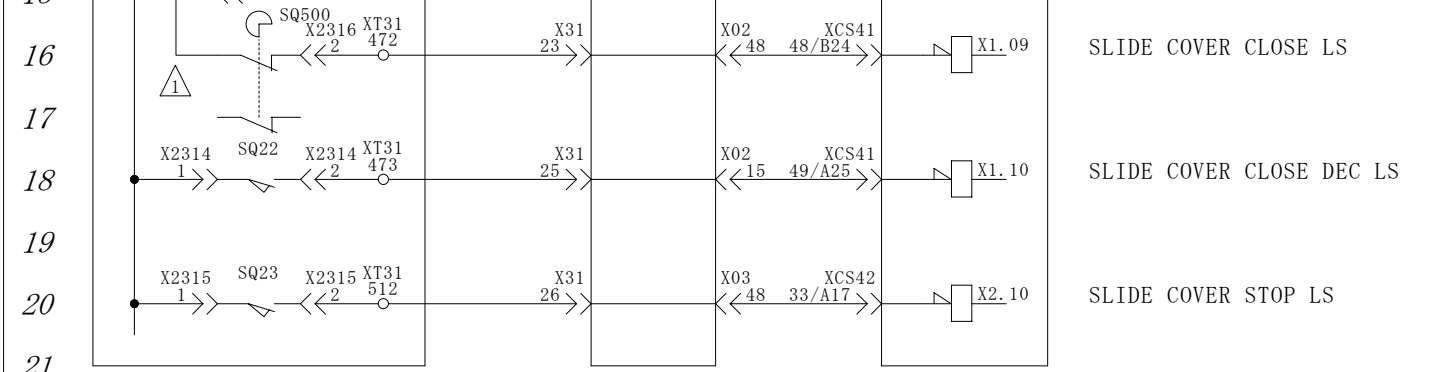

12 SLIDE COVER OPEN LS

13 SLIDE COVER OPEN DEC LS

14

15 SLIDE COVER CLOSE LS

16

17 SLIDE COVER CLOSE DEC LS

18

19 SLIDE COVER STOP LS

20

21

22

23

24

25

26

27

28

29

30

STD	48	510	612	
CE	1.5Kw	2.5Kw	4Kw	

	APR'D BY	CHK'D BY	DRWN BY	TITLE
	99/11/30	99/11/30	99/11/30	SLIDE COVER(1) (OPTION)
	T. Inoue	M Okajima	M Okajima	DRWN NO. 676 001 41801, 0



This product is subject to all the applicable Japanese Foreign Exchange and Foreign Trade Law.
 本品は『外国為替及び外国貿易法』に該当しますので外国に輸出する場合には同法に基づく許可を必要とします。

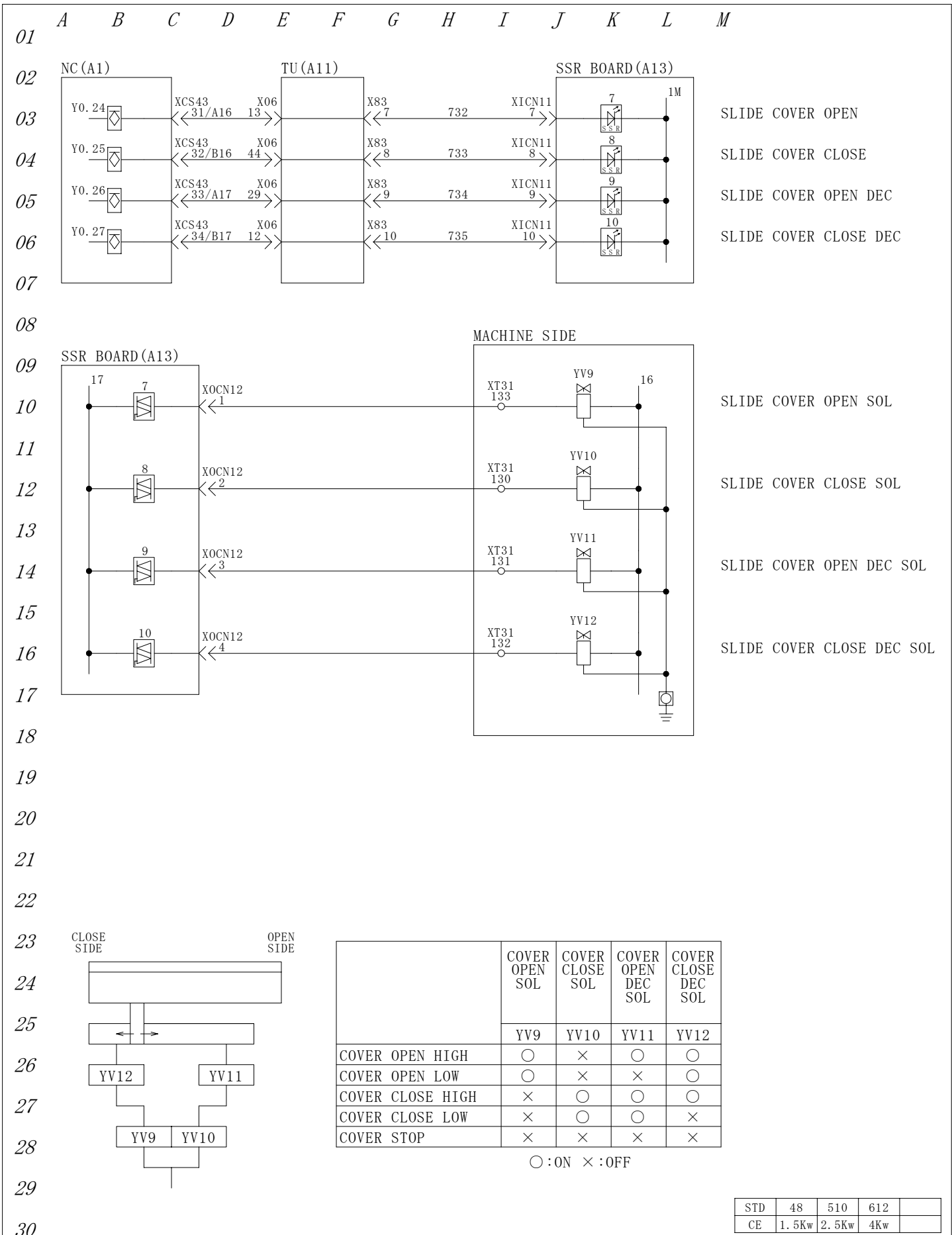

△		 YAMAZAKI MAZAK CORPORATION	APR' D BY	CHK' D BY	DRWN BY	TITLE
△			99/11/30	99/11/30	99/11/30	SLIDE COVER (2) (OPTION)
△			T. Inoue	M Okaji ma	M Okaji ma	DRWN NO.
△						676 001 41810, 0
△						

This product is subject to all the applicable Japanese Foreign Exchange and Foreign Trade Law.
 本品は『外国為替及び外国貿易法』に該当しますので外国に輸出する場合には同法に基づく許可を必要とします。

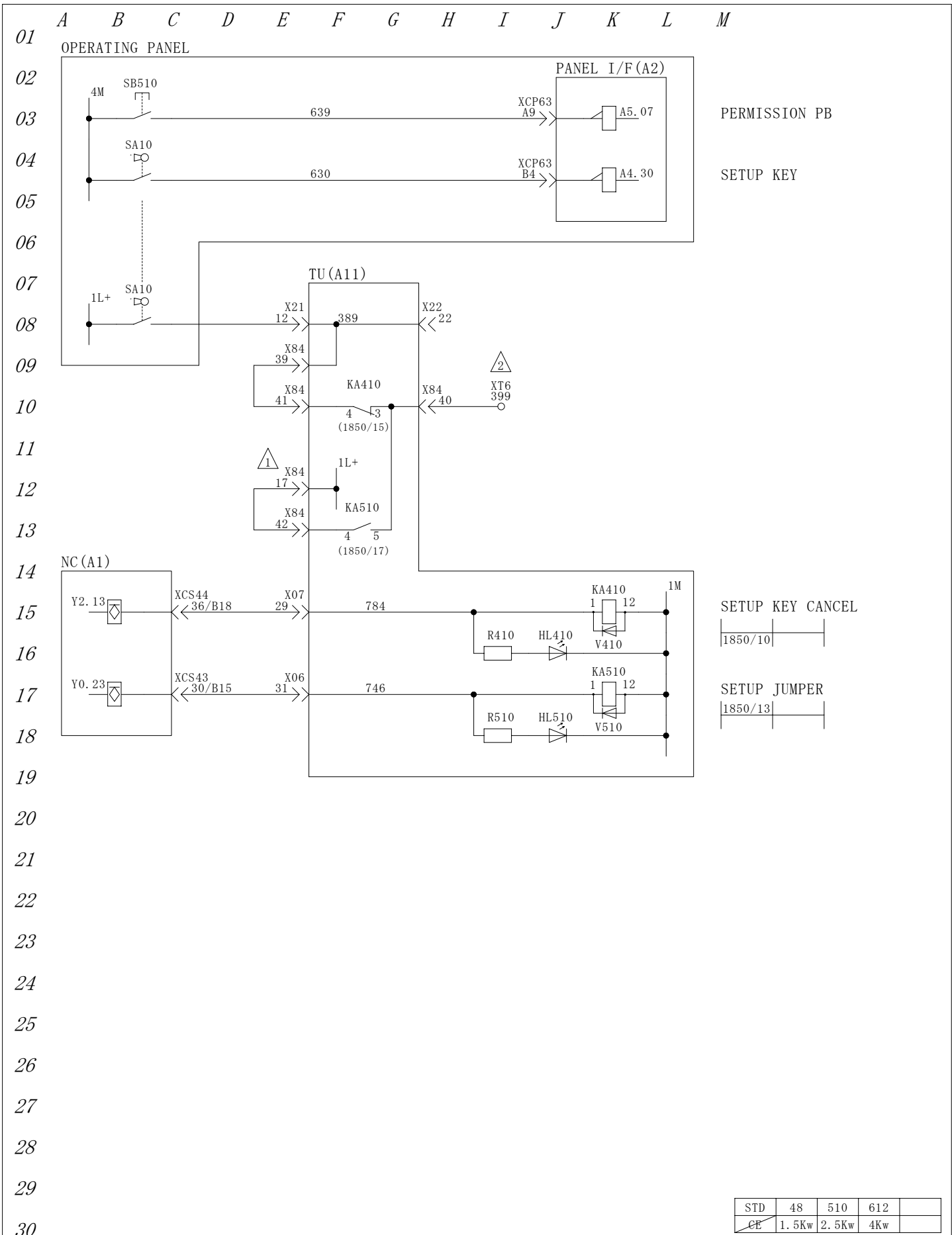

STD	48	510	612	
CE	1.5Kw	2.5Kw	4Kw	

△		 YAMAZAKI MAZAK CORPORATION	APR' D BY	CHK' D BY	DRWN BY	TITLE
△			99/11/30	99/11/30	99/11/30	SETUP
△	Edition Oct.05.'00 M.Okajima		T. Inoue	M Okajima	M Okajima	DRWN NO.
△	Edition Apr.07.'00 M.Okajima					676 001 41852.0

This product is subject to all the applicable Japanese Foreign Exchange and Foreign Trade Law.
 本品は『外国為替及び外国貿易法』に該当しますので外国に輸出する場合には同法に基づく許可を必要とします。

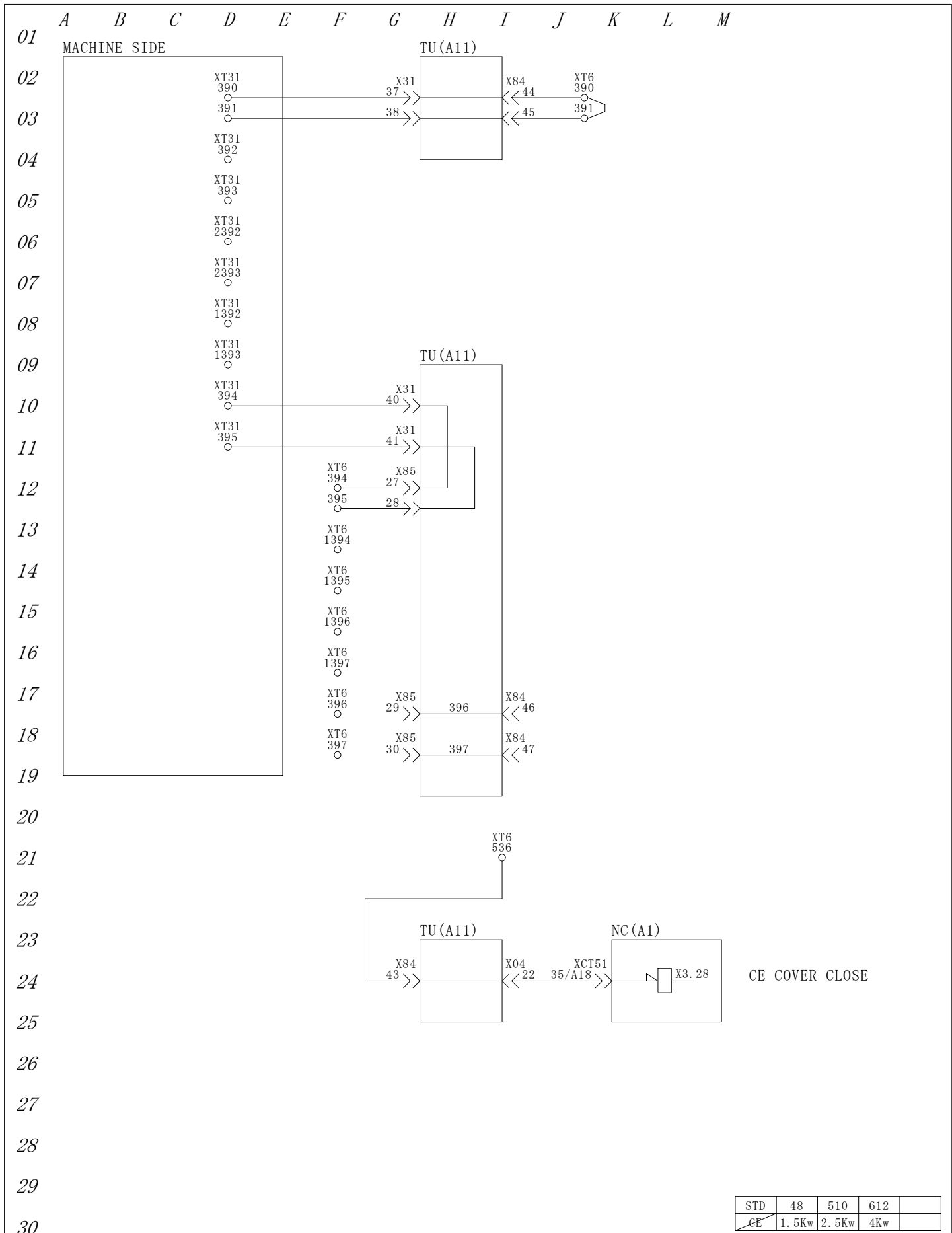

STD	48	510	612	
CE	1.5Kw	2.5Kw	4Kw	

△		 YAMAZAKI MAZAK CORPORATION	APR' D BY	CHK' D BY	DRWN BY	TITLE
△			99/11/30	99/11/30	99/11/30	CE COVER INTERLOCK (NOT USED)
△			T. Inoue	M Okajima	M Okajima	
△						DRWN NO. 676 001 41860, 0
△						

This product is subject to all the applicable Japanese Foreign Exchange and Foreign Trade Law.
 本品は『外国為替及び外国貿易法』に該当しますので外国に輸出する場合には同法に基づく許可を必要とします。

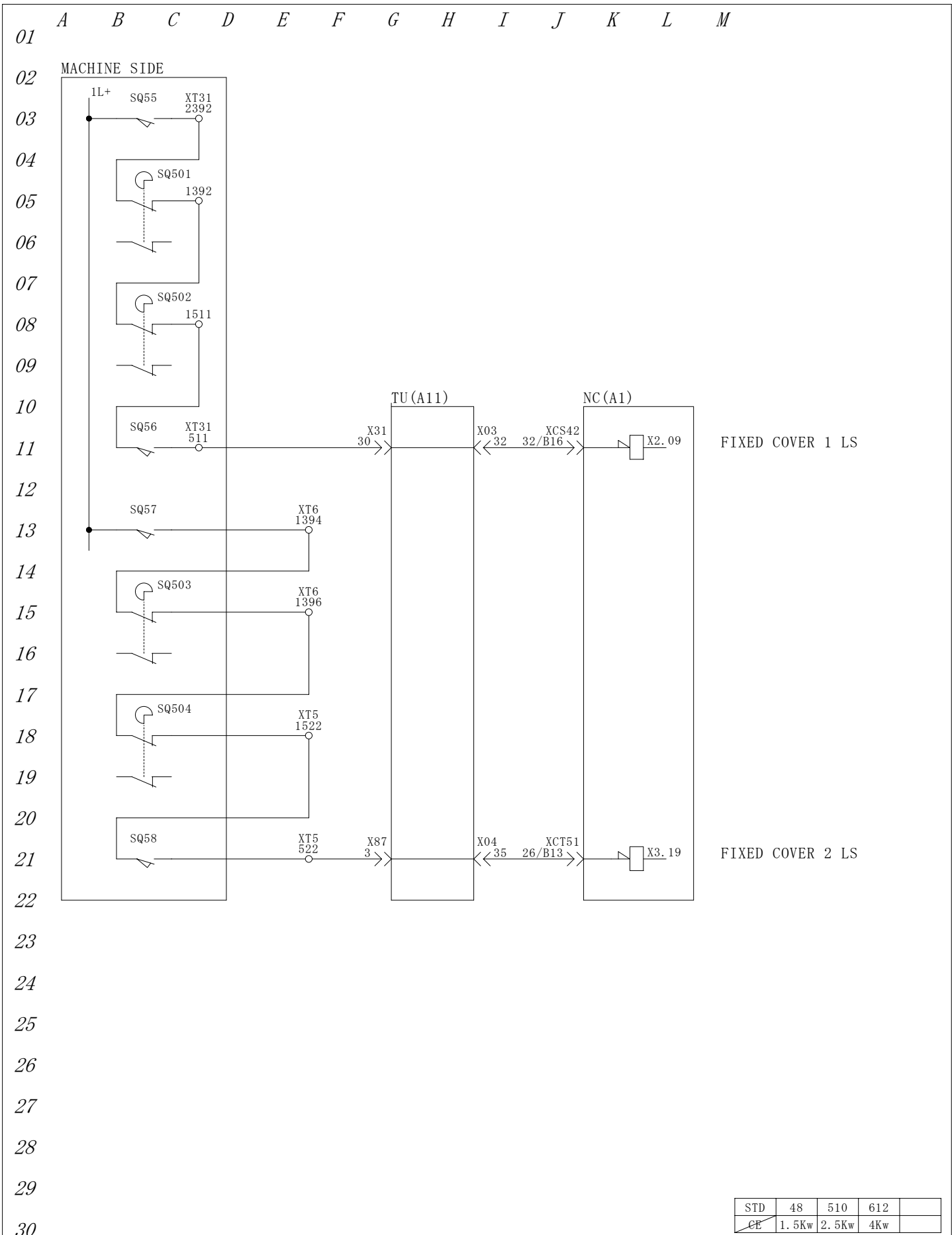

STD	48	510	612	
CE	1.5Kw	2.5Kw	4Kw	

△		 YAMAZAKI MAZAK CORPORATION	APR'D BY	CHK'D BY	DRWN BY	TITLE
△			04/06/03	04/06/03	04/06/03	FIXED COVER (OPTION)
△			T. Inoue	M Okajima	M Okajima	DRWN NO. 676 001 41900, 0
△						
△						

This product is subject to all the applicable Japanese Foreign Exchange and Foreign Trade Law.
 本品は『外国為替及び外国貿易法』に該当しますので外国に輸出する場合には同法に基づく許可を必要とします。

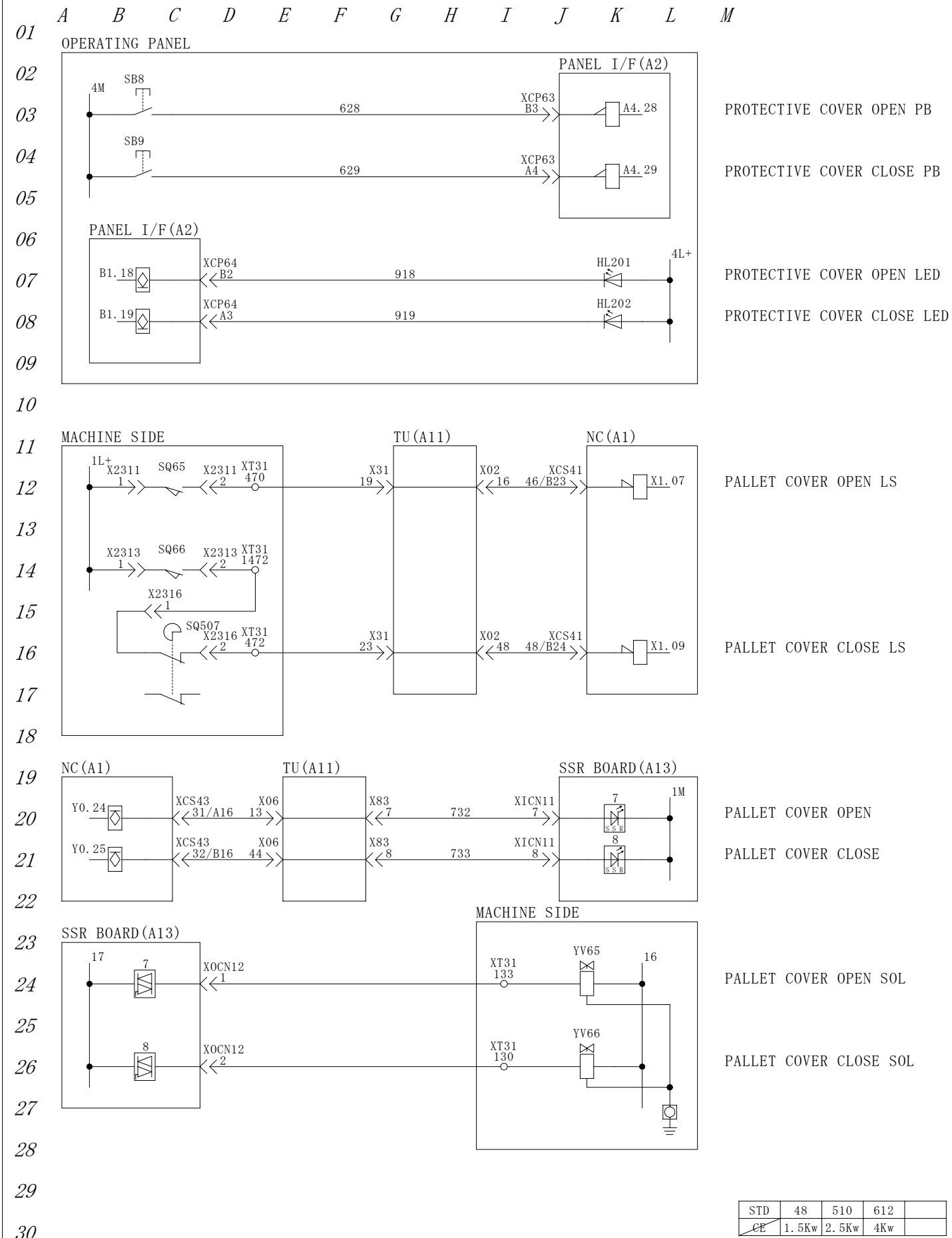

STD	48	510	612	
CE	1.5Kw	2.5Kw	4Kw	

	APR'D BY	CHK'D BY	DRWN BY	TITLE
	04/06/03	04/06/03	04/06/03	PALLET COVER (OPTION)
	T. Inoue	M Okajima	M Okajima	DRWN NO. 676 001 41950, 0



This product is subject to all the applicable Japanese Foreign Exchange and Foreign Trade Law. 本品は『外国為替及び外国貿易法』に該当しますので外国に輸出する場合には同法に基づく許可を必要とします。

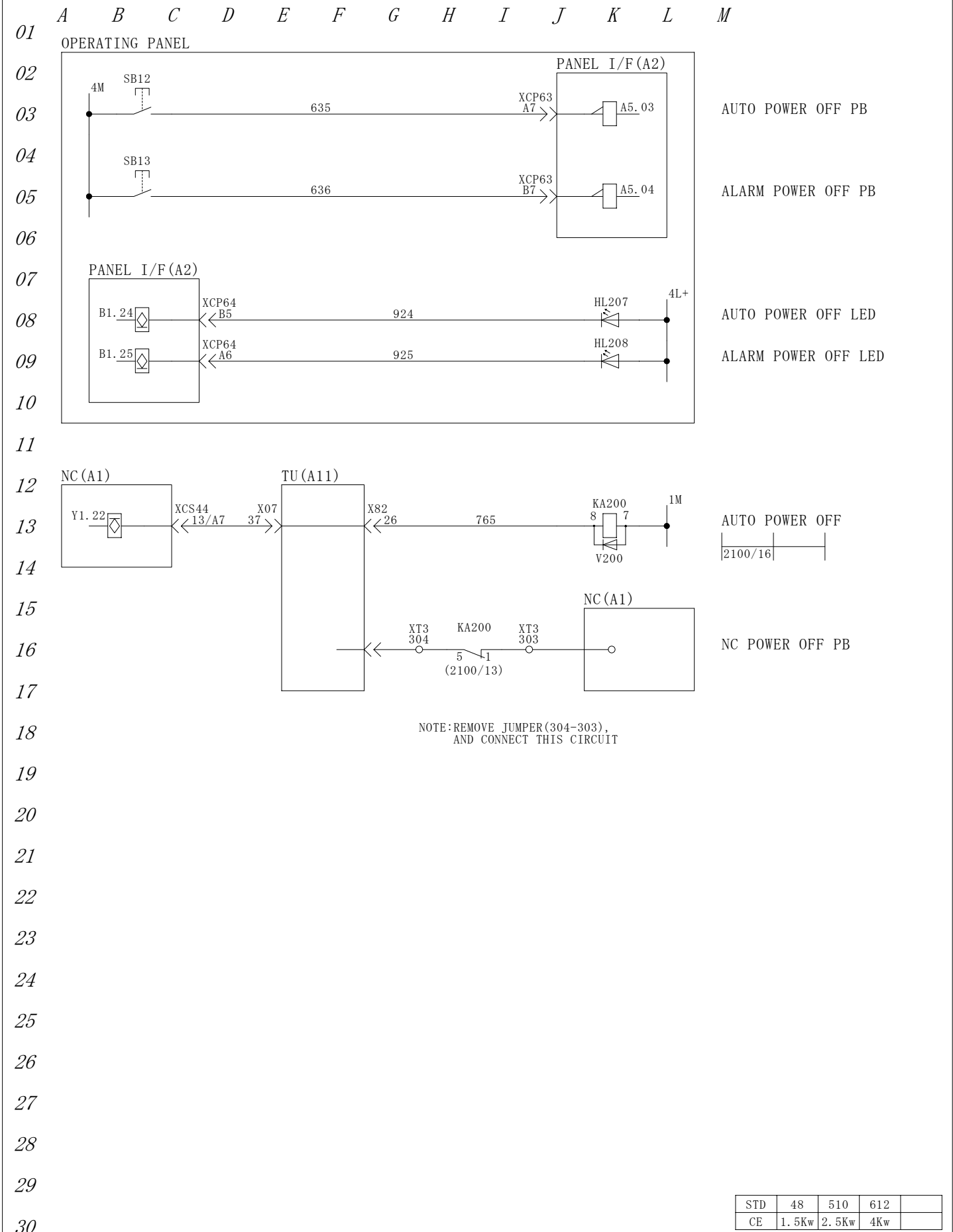

△		 YAMAZAKI MAZAK CORPORATION	APR'D BY	CHK'D BY	DRWN BY	TITLE
△			99/11/30	99/11/30	99/11/30	AUTO/ALARM POWER OFF (OPTION)
△			T. Inoue	M Okajima	M Okajima	DRWN NO. 676 001 42100, 0
△						
△						

This product is subject to all the applicable Japanese Foreign Exchange and Foreign Trade Law.
 本品は『外国為替及び外国貿易法』に該当しますので外国に輸出する場合には同法に基づく許可を必要とします。

01 A B C D E F G H I J K L M

02

03 FOR JAPAN

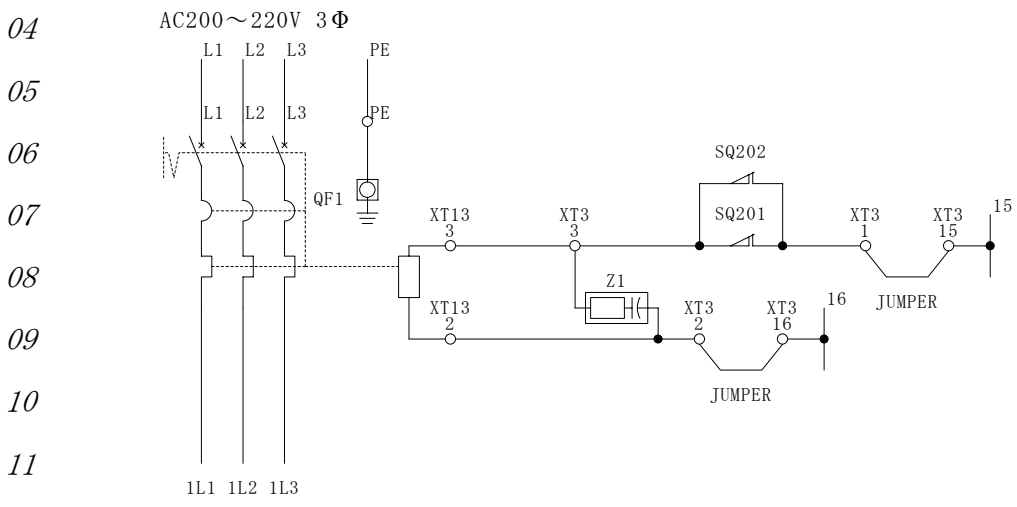

DOOR LS
DOOR OPEN (LS OFF) : QF1 SHUNT
DOOR CLOSE (LS ON) : NORMAL

13

14 FOR EXPORT

15 MACHINE SIDE

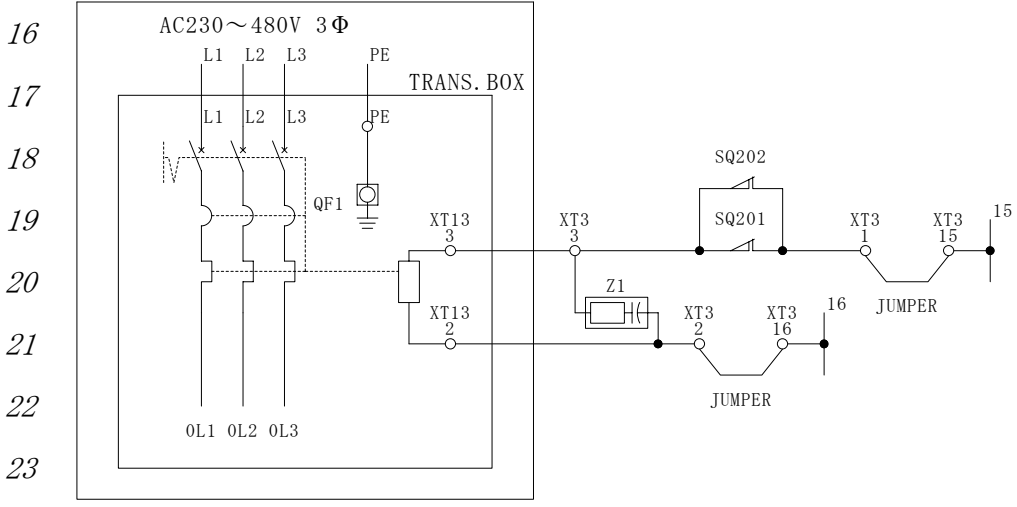

DOOR LS
DOOR OPEN (LS OFF) : QF1 SHUNT
DOOR CLOSE (LS ON) : NORMAL

26 \triangle

LASER	QF1
1.5/1.8KW	125A 500mA TBM
2.5KW	200A 500mA TBM
4KW	250A 500mA TBM

STD	48	510	612	
CE	1.5Kw	2.5Kw	4Kw	

APR'D BY 99/11/30 T. Inoue	CHK'D BY 99/11/30 M Okajima	DRWN BY 99/11/30 M Okajima	TITLE LEAK DETECTION BREAKER (OPTION) DRWN NO. 676 001 42201,0
----------------------------------	-----------------------------------	----------------------------------	---



This product is subject to all the applicable Japanese Foreign Exchange and Foreign Trade Law.
本品は『外国為替及び外国貿易法』に該当しますので外国に輸出する場合には同法に基づく許可を必要とします。

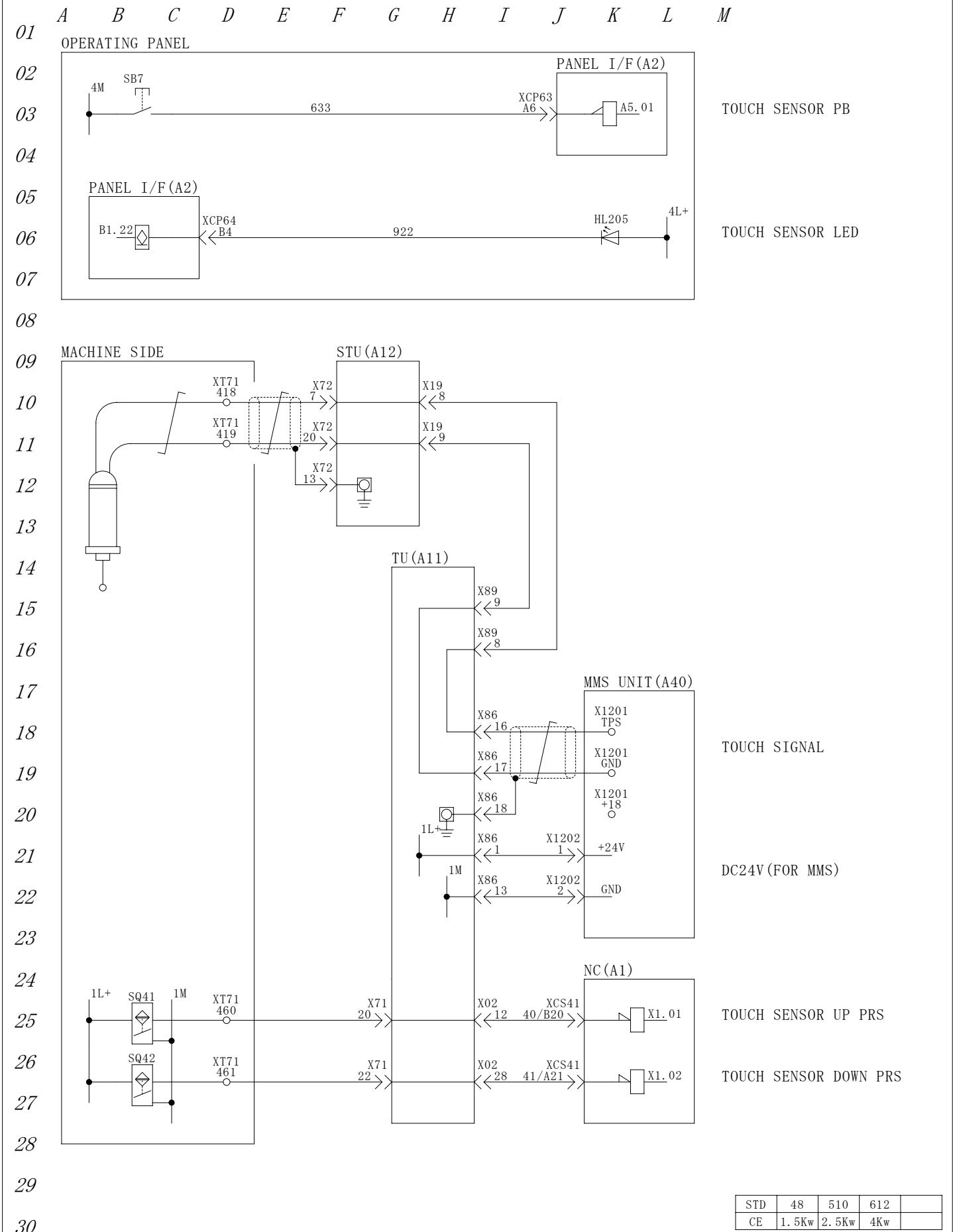

STD	48	510	612	
CE	1.5Kw	2.5Kw	4Kw	

APR'D BY	CHK'D BY	DRWN BY	TITLE
99/11/30	99/11/30	99/11/30	TOUCH SENSOR(1) (NOT USED)
T. Inoue	M Okajima	M Okajima	DRWN NO. 676 001 42500, 0



This product is subject to all the applicable Japanese Foreign Exchange and Foreign Trade Law.
 本品は『外国為替及び外国貿易法』に該当しますので外国に輸出する場合には同法に基づく許可を必要とします。

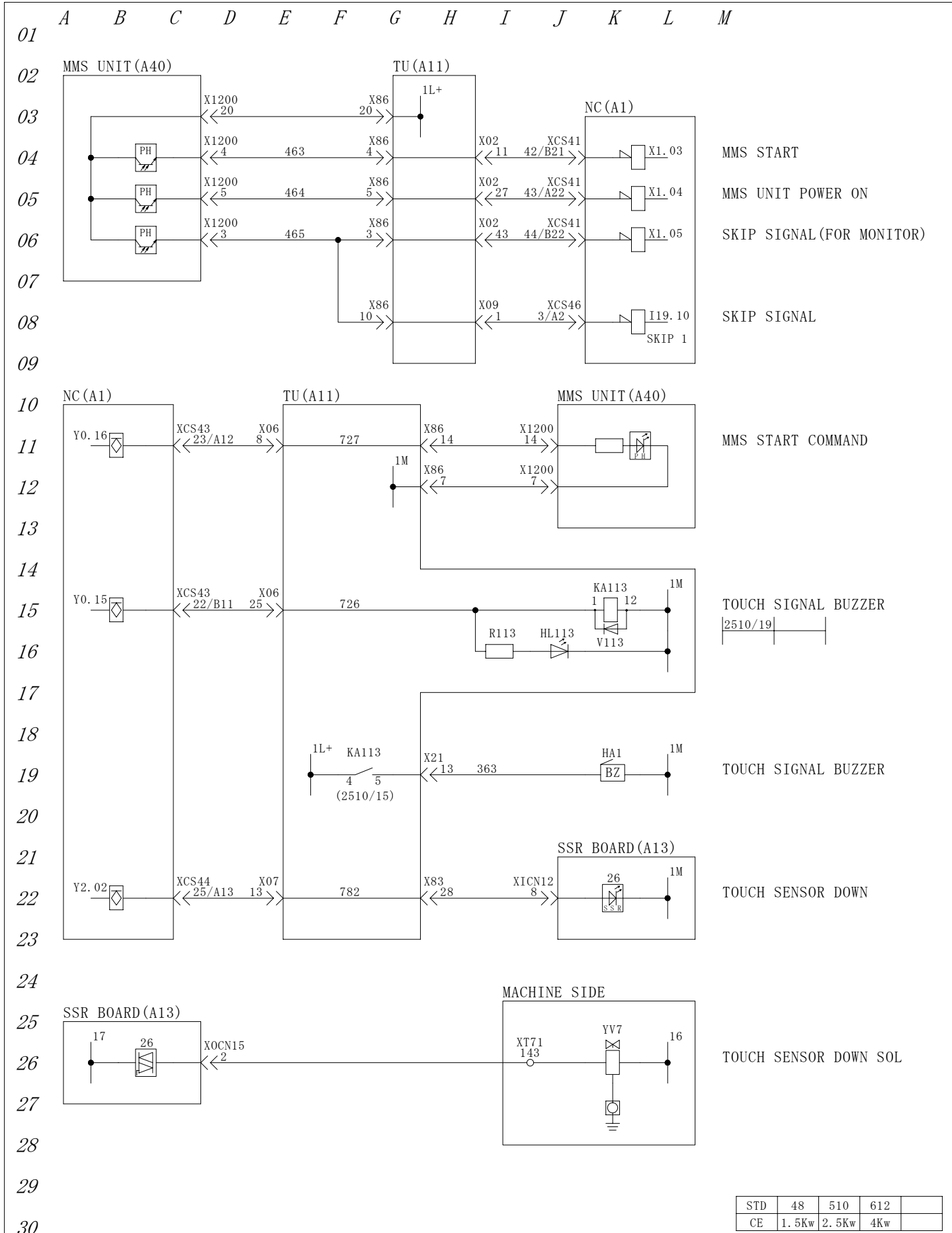

STD	48	510	612	
CE	1.5Kw	2.5Kw	4Kw	

△		 YAMAZAKI MAZAK CORPORATION	APR' D BY	CHK' D BY	DRWN BY	TITLE
△			99/11/30	99/11/30	99/11/30	TOUCH SENSOR (2)
△			T. Inoue	M Okajima	M Okajima	(NOT USED)
△						DRWN NO.
△						676 001 42510, 0

This product is subject to all the applicable Japanese Foreign Exchange and Foreign Trade Law.
 本品は『外国為替及び外国貿易法』に該当しますので外国に輸出する場合には同法に基づく許可を必要とします。

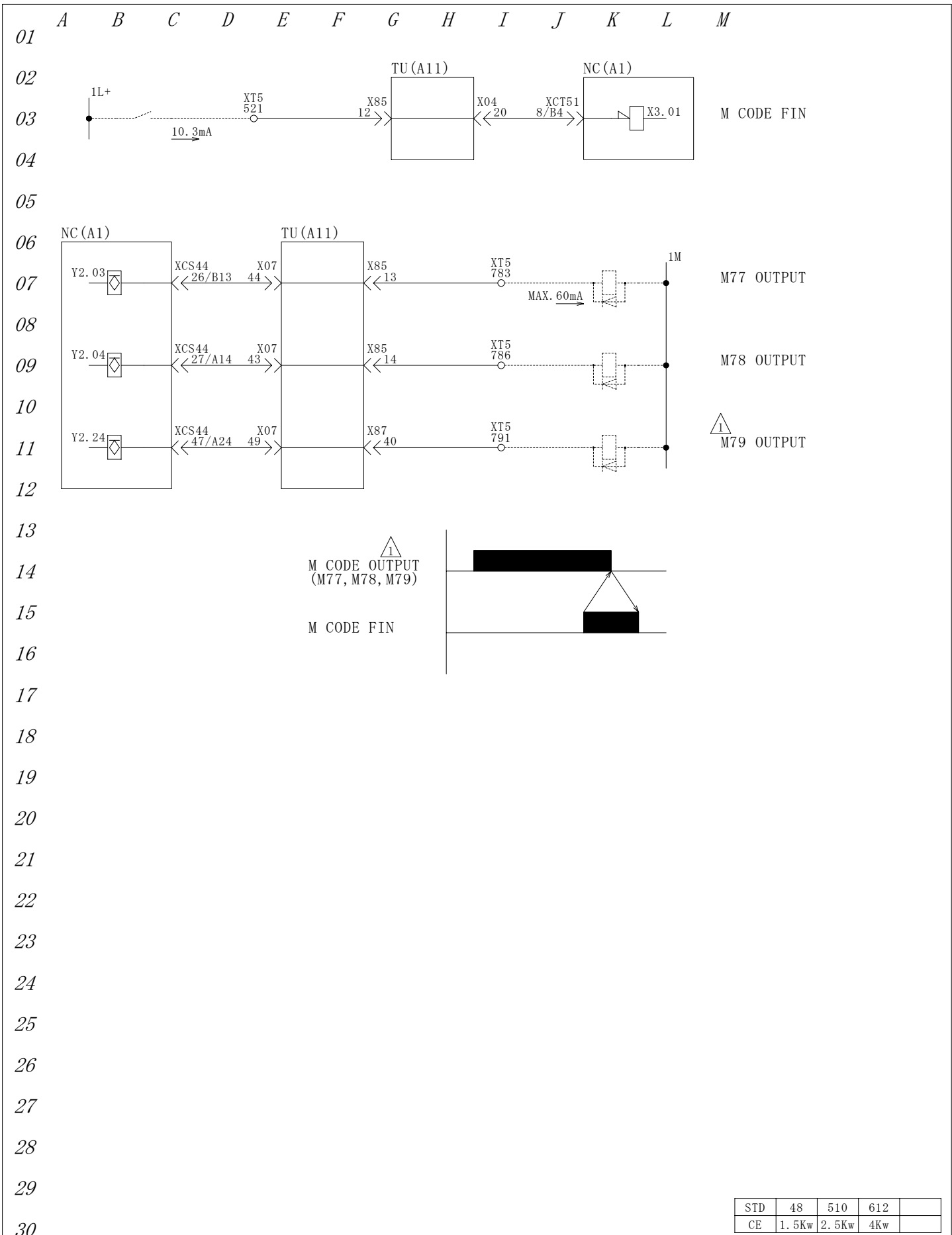

STD	48	510	612	
CE	1.5Kw	2.5Kw	4Kw	

△		 YAMAZAKI MAZAK CORPORATION	APR'D BY	CHK'D BY	DRWN BY	TITLE
△			99/11/30	99/11/30	99/11/30	SPARE M CODE (OPTION)
△			T. Inoue	M Okajima	M Okajima	DRWN NO.
△			676 001 42901, 0			

This product is subject to all the applicable Japanese Foreign Exchange and Foreign Trade Law.
 本品は『外国為替及び外国貿易法』に該当しますので外国に輸出する場合には同法に基づく許可を必要とします。

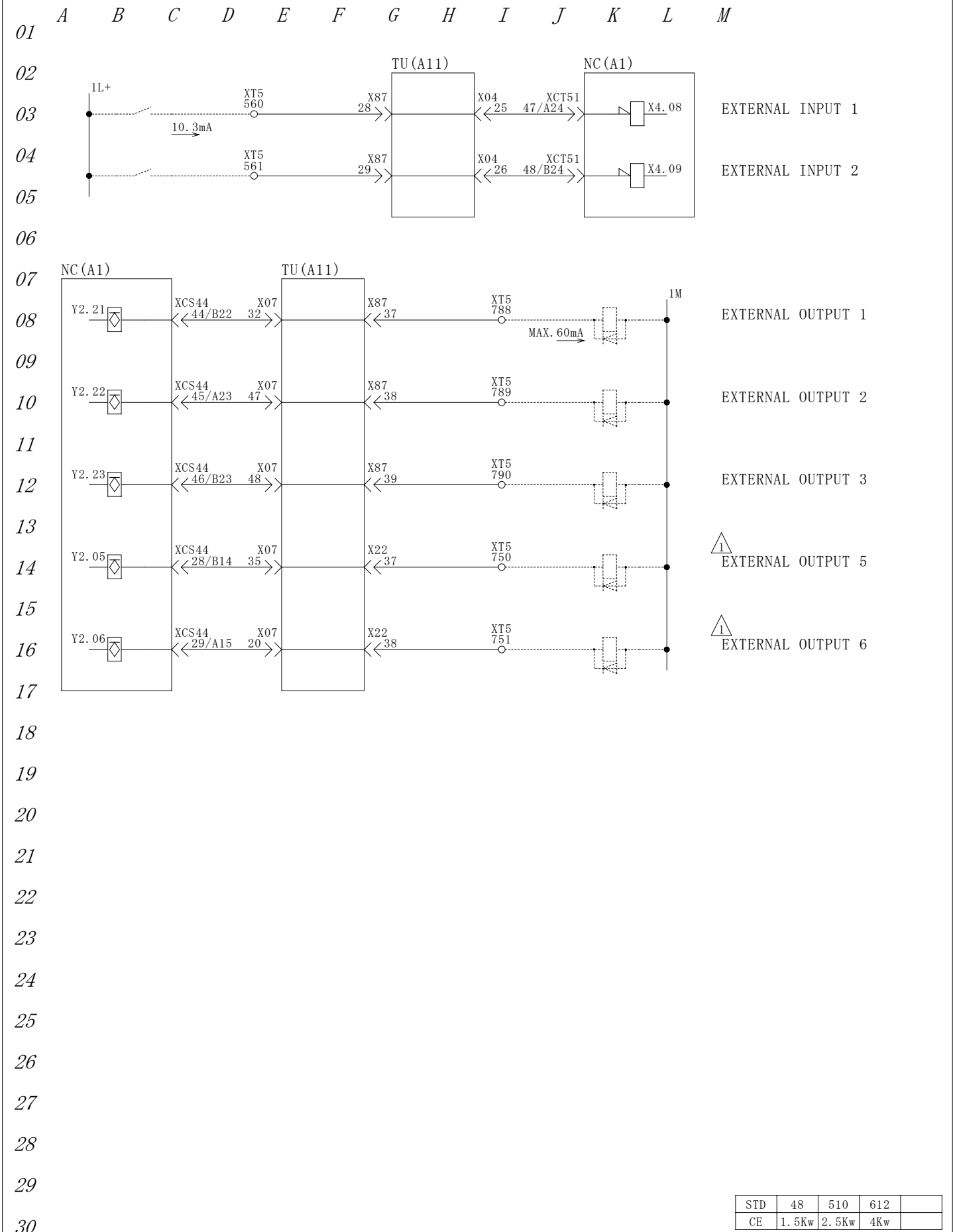

STD	48	510	612	
CE	1.5Kw	2.5Kw	4Kw	

△		 YAMAZAKI MAZAK CORPORATION	APR'D BY	CHK'D BY	DRWN BY	TITLE
△			99/11/30	99/11/30	99/11/30	EXTERNAL SIGNAL (OPTION)
△			T. Inoue	M Okajima	M Okajima	DRWN NO. 676 001 42911, 0
△	Edition Apr.12.'01 M.Okajima					

This product is subject to all the applicable Japanese Foreign Exchange and Foreign Trade Law.
 本品は『外国為替及び外国貿易法』に該当しますので外国に輸出する場合には同法に基づく許可を必要とします。

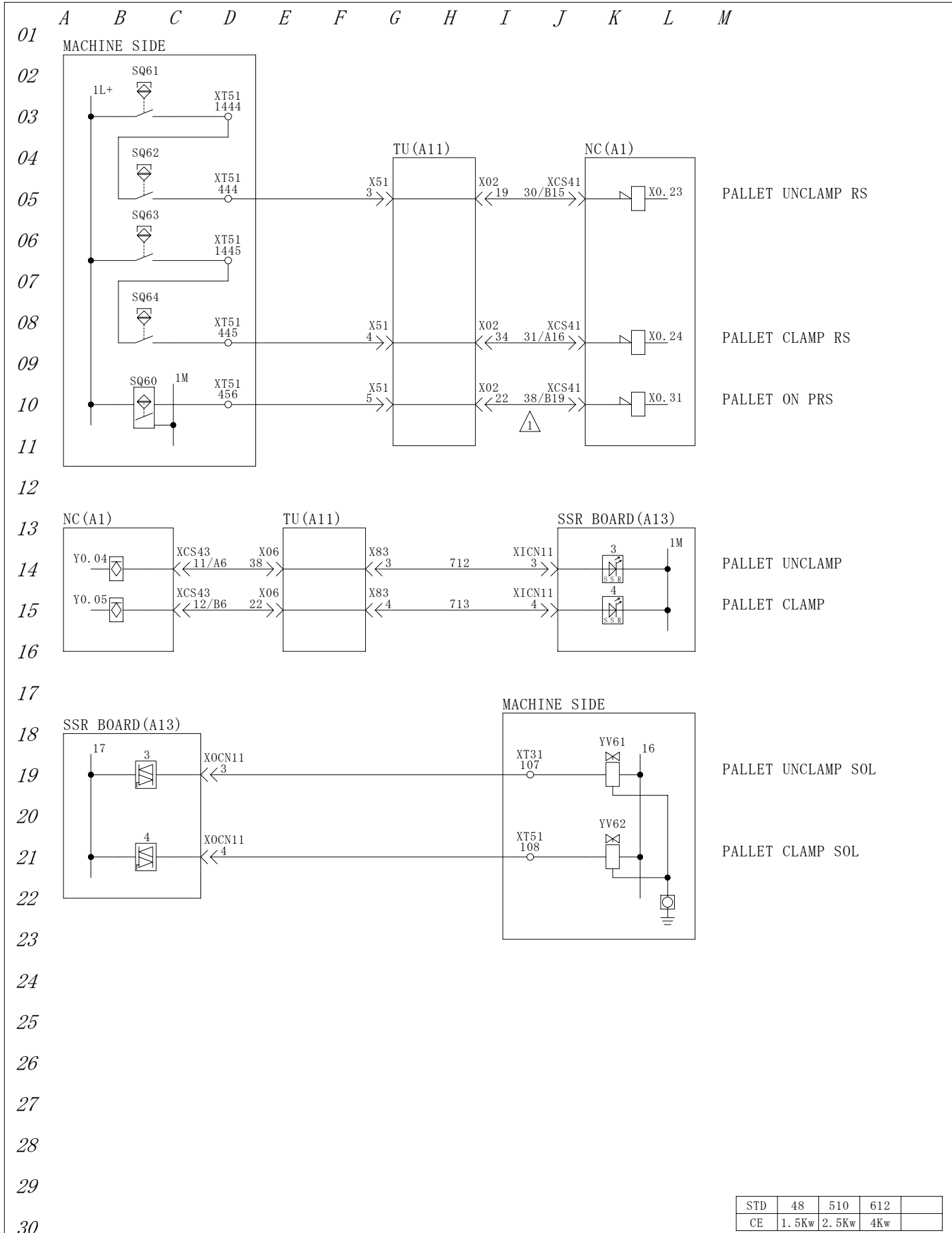

STD	48	510	612	
CE	1.5Kw	2.5Kw	4Kw	

△		 YAMAZAKI MAZAK CORPORATION	APR'D BY	CHK'D BY	DRWN BY	TITLE
△			99/11/30	99/11/30	99/11/30	PALLET CLAMP (OPTION)
△			T. Inoue	M Okajima	M Okajima	DRWN NO. 676 001 43001, 0
△	Edition Mar. 27. '00 M. Okajima					

This product is subject to all the applicable Japanese Foreign Exchange and Foreign Trade Law.
 本品は『外国為替及び外国貿易法』に該当しますので外国に輸出する場合には同法に基づく許可を必要とします。

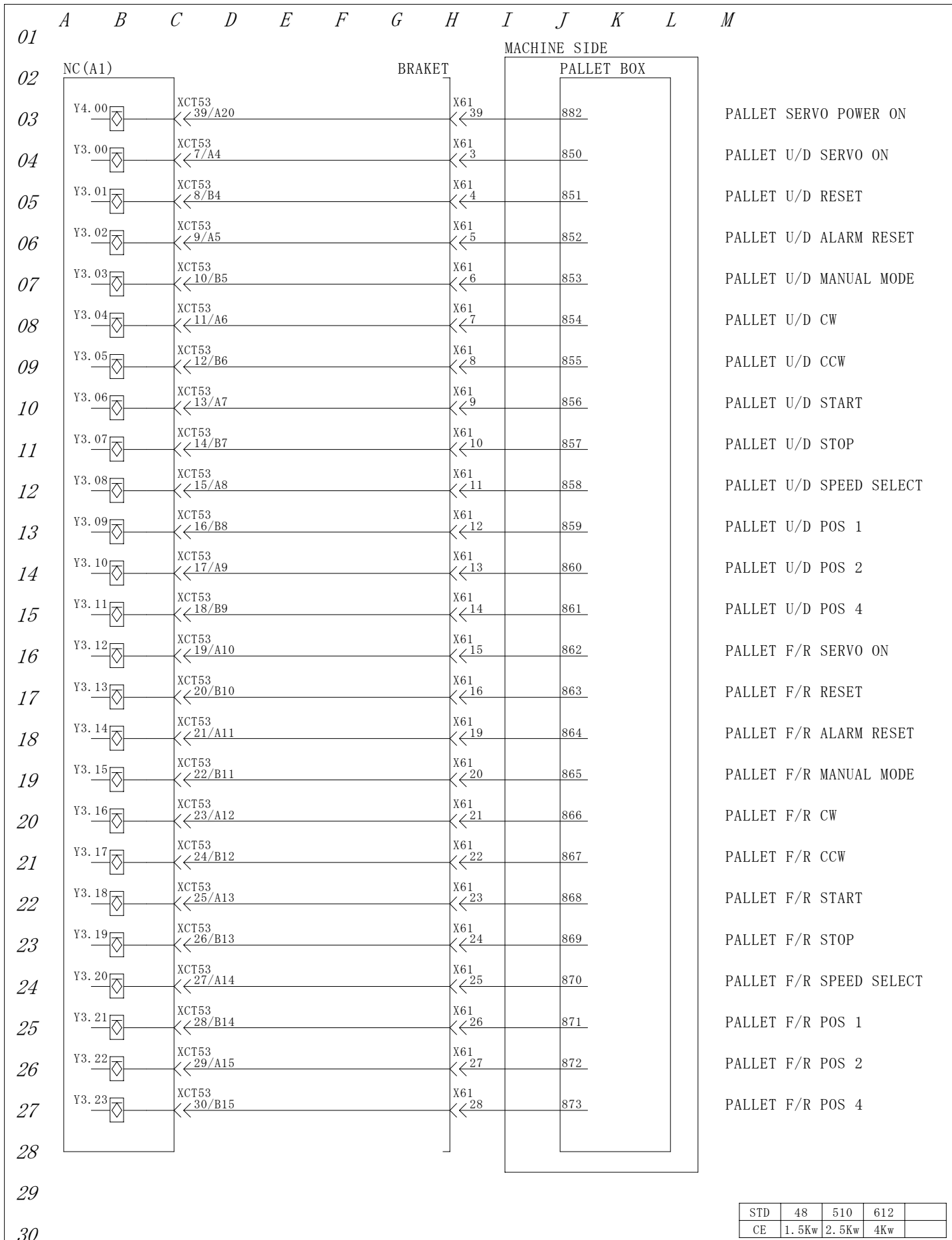

STD	48	510	612	
CE	1.5Kw	2.5Kw	4Kw	

△		 YAMAZAKI MAZAK CORPORATION	APR'D BY	CHK'D BY	DRWN BY	TITLE
△			99/11/30	99/11/30	99/11/30	PALLET INTERFACE (1) (OPTION)
△			T. Inoue	M Okajima	M Okajima	DRWN NO.
△			676 001 43100, 0			
△						

This product is subject to all the applicable Japanese Foreign Exchange and Foreign Trade Law.
 本品は『外国為替及び外国貿易法』に該当しますので外国に輸出する場合には同法に基づく許可を必要とします。

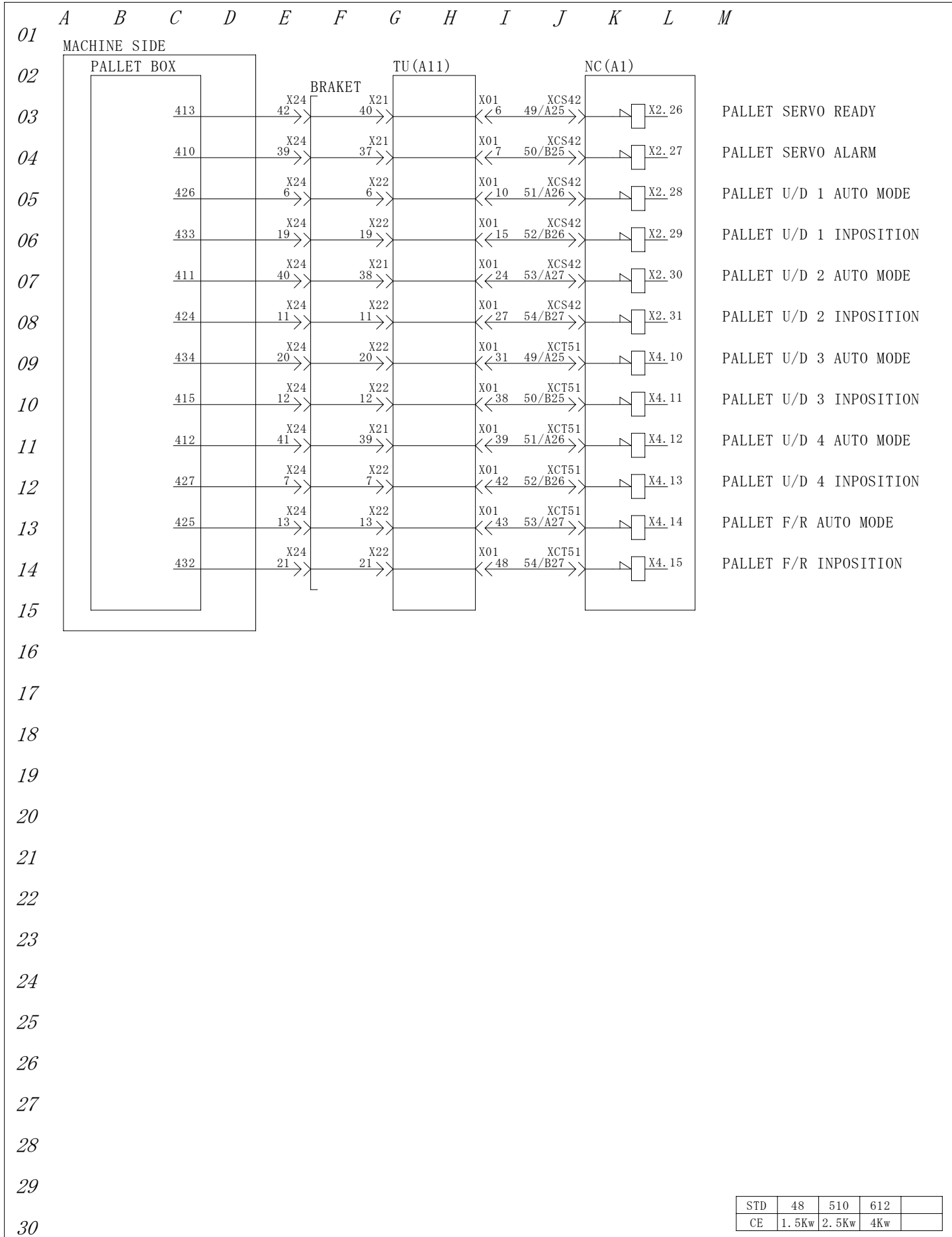

STD	48	510	612	
CE	1.5Kw	2.5Kw	4Kw	

△		 YAMAZAKI MAZAK CORPORATION	APR' D BY	CHK' D BY	DRWN BY	TITLE
△			99/11/30	99/11/30	99/11/30	PALLET INTERFACE (2) (OPTION)
△			T. Inoue	M Okajima	M Okajima	DRWN NO.
△						676 001 43110, 0
△						

This product is subject to all the applicable Japanese Foreign Exchange and Foreign Trade Law.
 本品は『外国為替及び外国貿易法』に該当しますので外国に輸出する場合には同法に基づく許可を必要とします。

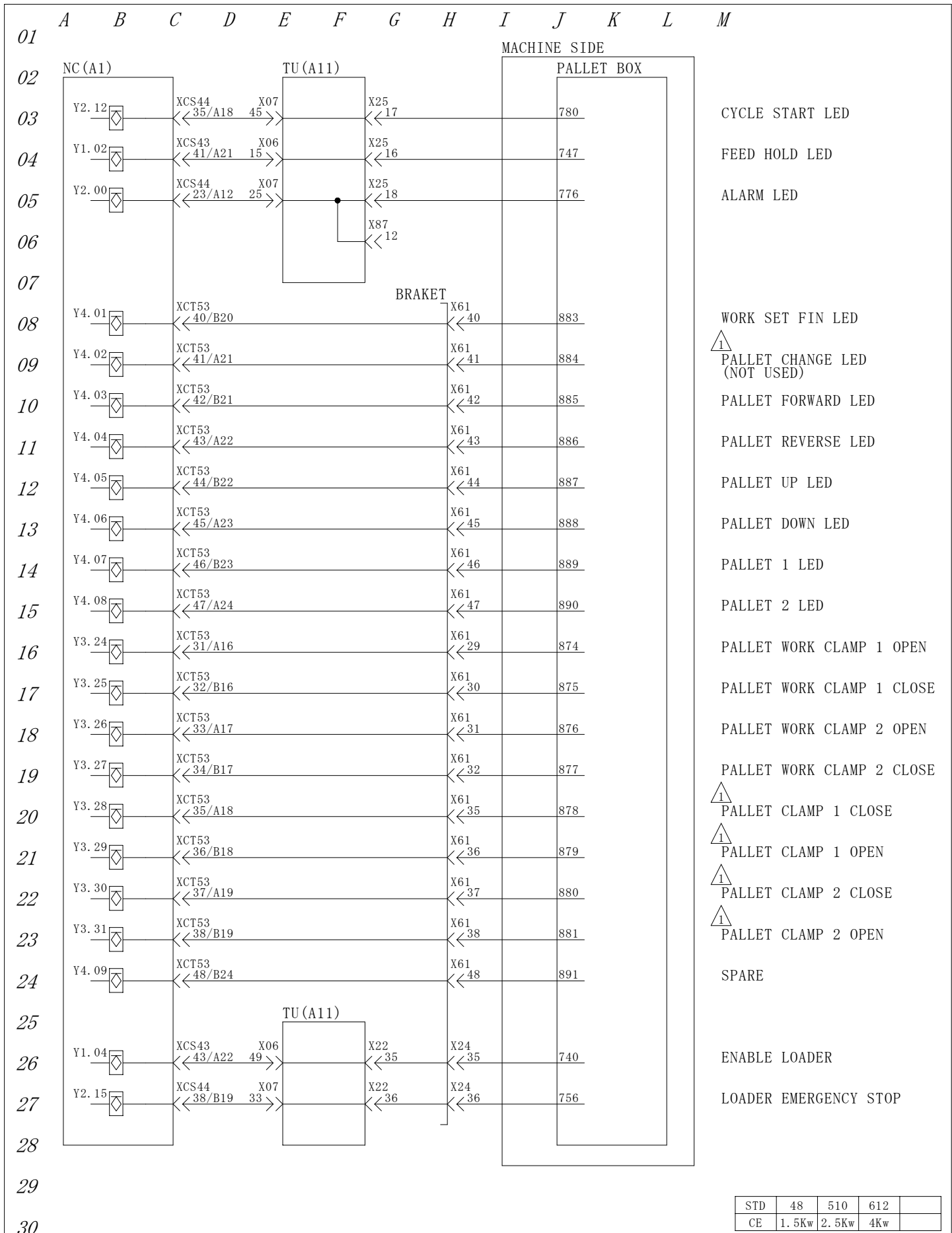



STD	48	510	612	
CE	1.5Kw	2.5Kw	4Kw	

¹				APR'D BY	CHK'D BY	DRWN BY	TITLE
¹				99/11/30	99/11/30	99/11/30	PALLET INTERFACE (3) (OPTION)
¹				T. Inoue	M Okajima	M Okajima	DRWN NO. 676 001 43121, 0
¹				Edition Jul.01.'00 M.Okajima			

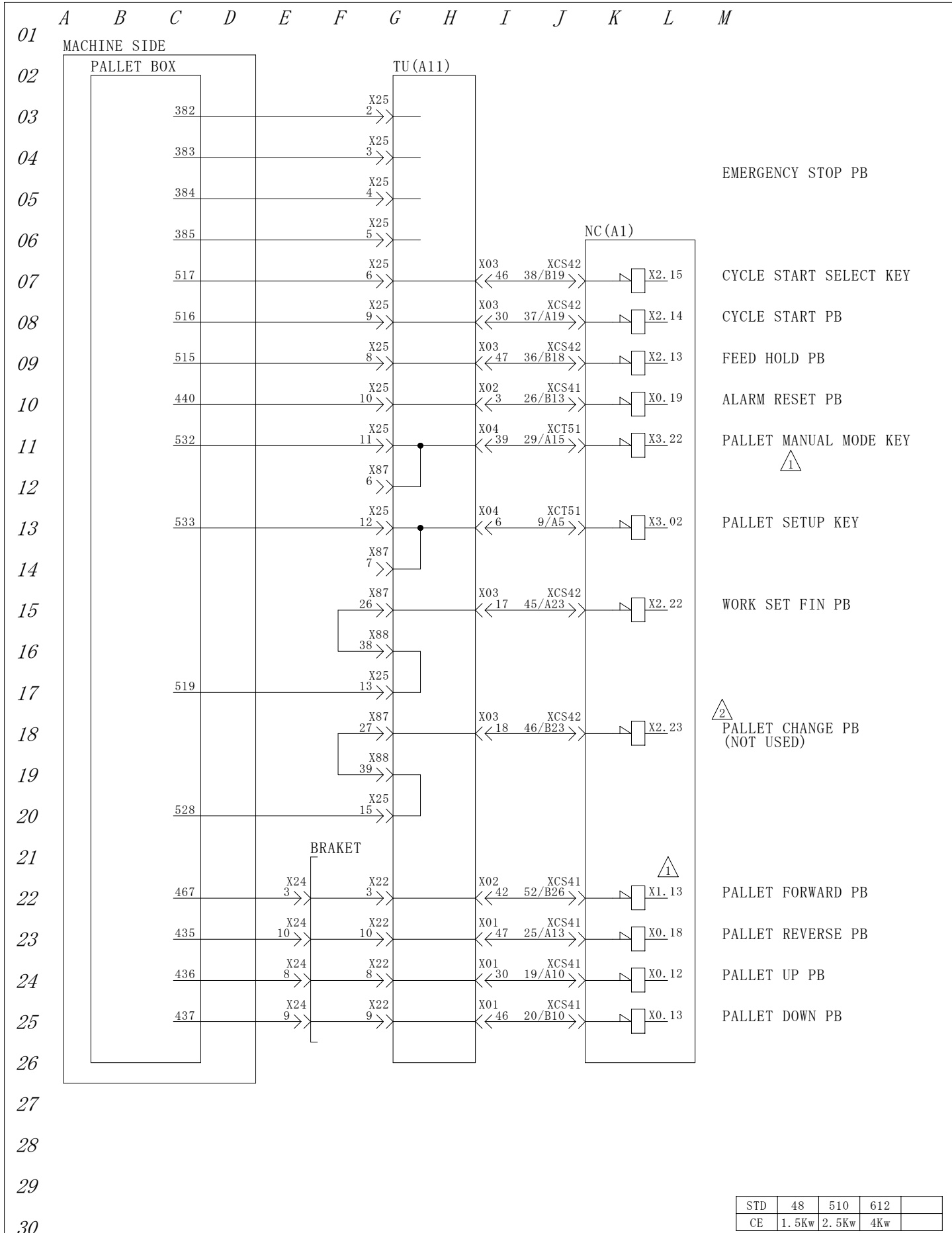

This product is subject to all the applicable Japanese Foreign Exchange and Foreign Trade Law.
 本品は『外国為替及び外国貿易法』に該当しますので外国に輸出する場合には同法に基づく許可を必要とします。



△		 YAMAZAKI MAZAK CORPORATION	APR' D BY	CHK' D BY	DRWN BY	TITLE
△			99/11/30	99/11/30	99/11/30	PALLET INTERFACE (4) (OPTION)
△			T. Inoue	M Okajima	M Okajima	DRWN NO. 676 001 43132.0
△	Edition Jul.01.'00 M.Okajima					
△	Edition Apr.07.'00 M.Okajima					

This product is subject to all the applicable Japanese Foreign Exchange and Foreign Trade Law.
 本品は『外国為替及び外国貿易法』に該当しますので外国に輸出する場合には同法に基づく許可を必要とします。

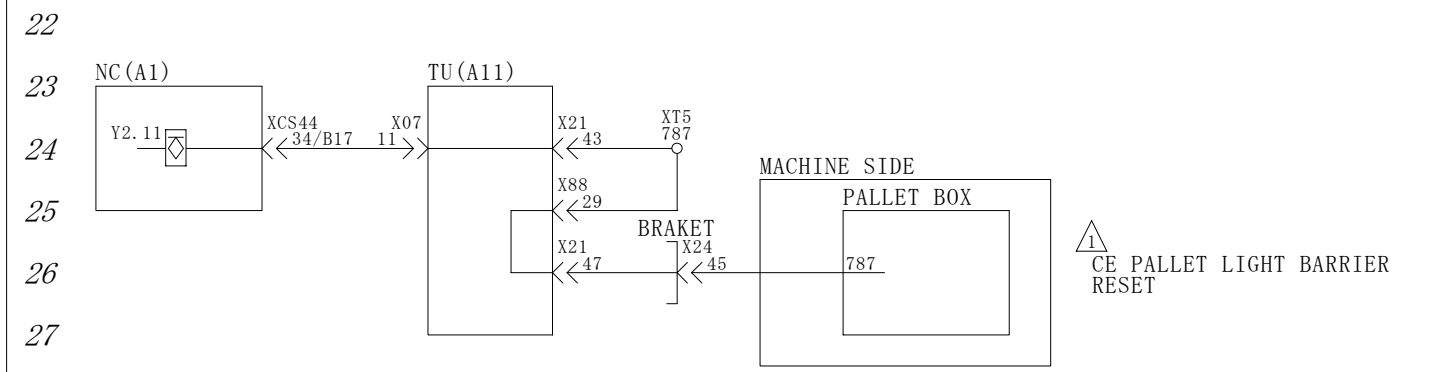
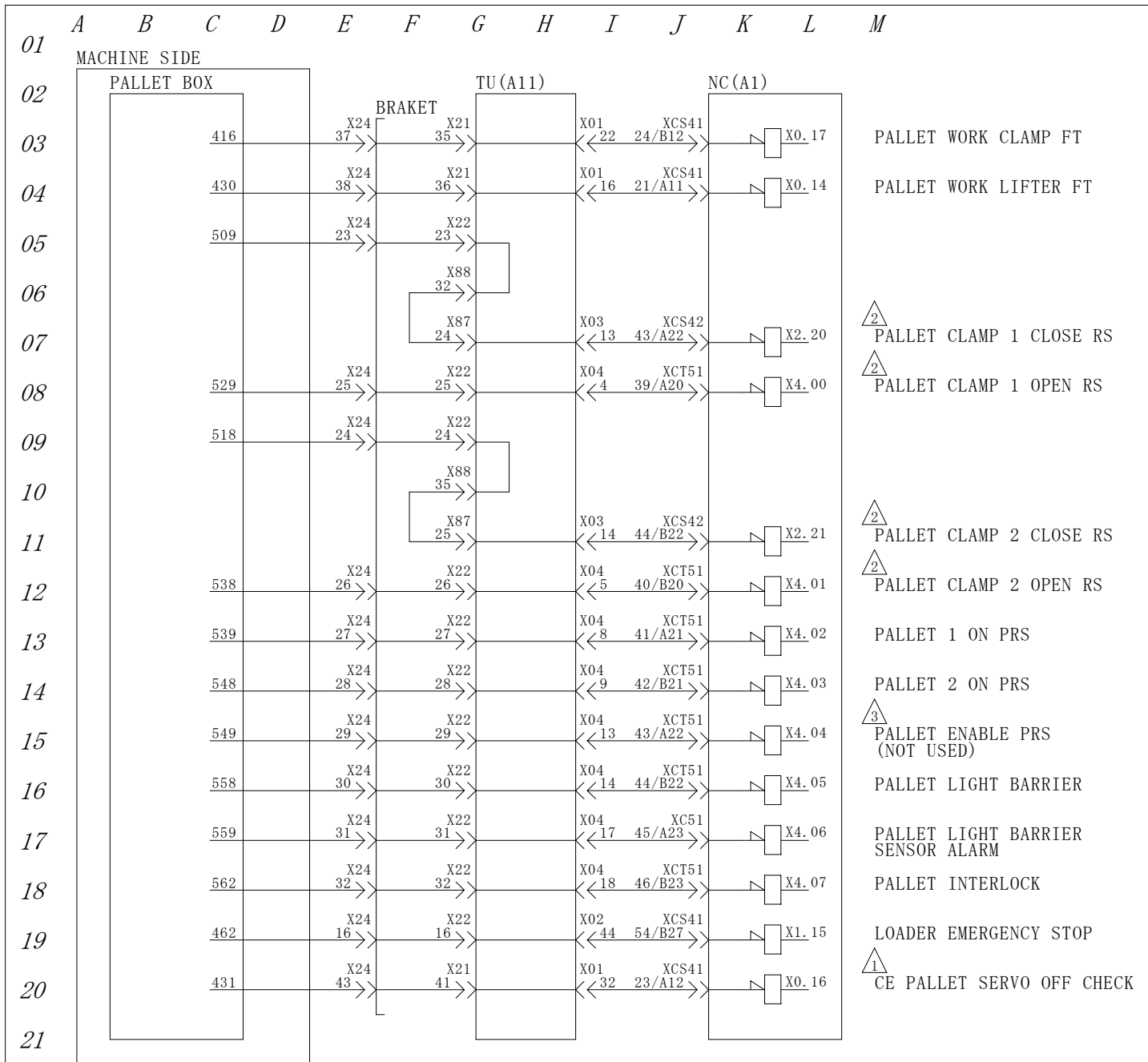

STD	48	510	612	
CE	1.5Kw	2.5Kw	4Kw	

APR'D BY	CHK'D BY	DRWN BY	TITLE
99/11/30	99/11/30	99/11/30	PALLET INTERFACE (5) (OPTION)
T. Inoue	M Okajima	M Okajima	DRWN NO. 676 001 43143, 0



This product is subject to all the applicable Japanese Foreign Exchange and Foreign Trade Law. 本品は『外国為替及び外国貿易法』に該当しますので外国に輸出する場合には同法に基づく許可を必要とします。

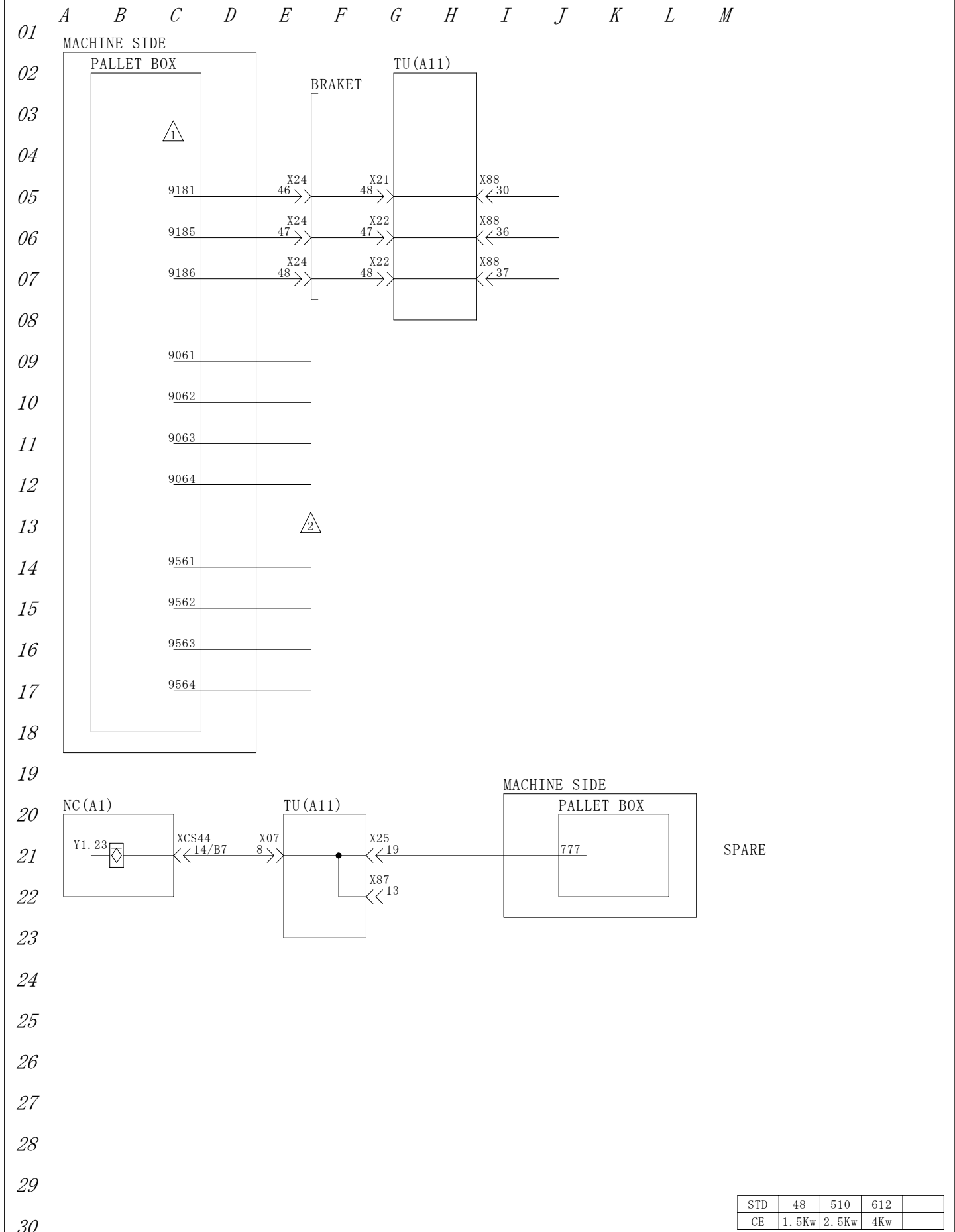

STD	48	510	612	
CE	1.5Kw	2.5Kw	4Kw	

△		 YAMAZAKI MAZAK CORPORATION	APR'D BY	CHK'D BY	DRWN BY	TITLE
△			99/11/30	99/11/30	99/11/30	PALLET INTERFACE (6) (OPTION)
△			T. Inoue	M Okajima	M Okajima	DRWN NO.
△	Edition Oct.05.'00 M.Okajima		676 001 43152,0			
△	Edition Apr.07.'00 M.Okajima					

This product is subject to all the applicable Japanese Foreign Exchange and Foreign Trade Law.
 本品は『外国為替及び外国貿易法』に該当しますので外国に輸出する場合には同法に基づく許可を必要とします。

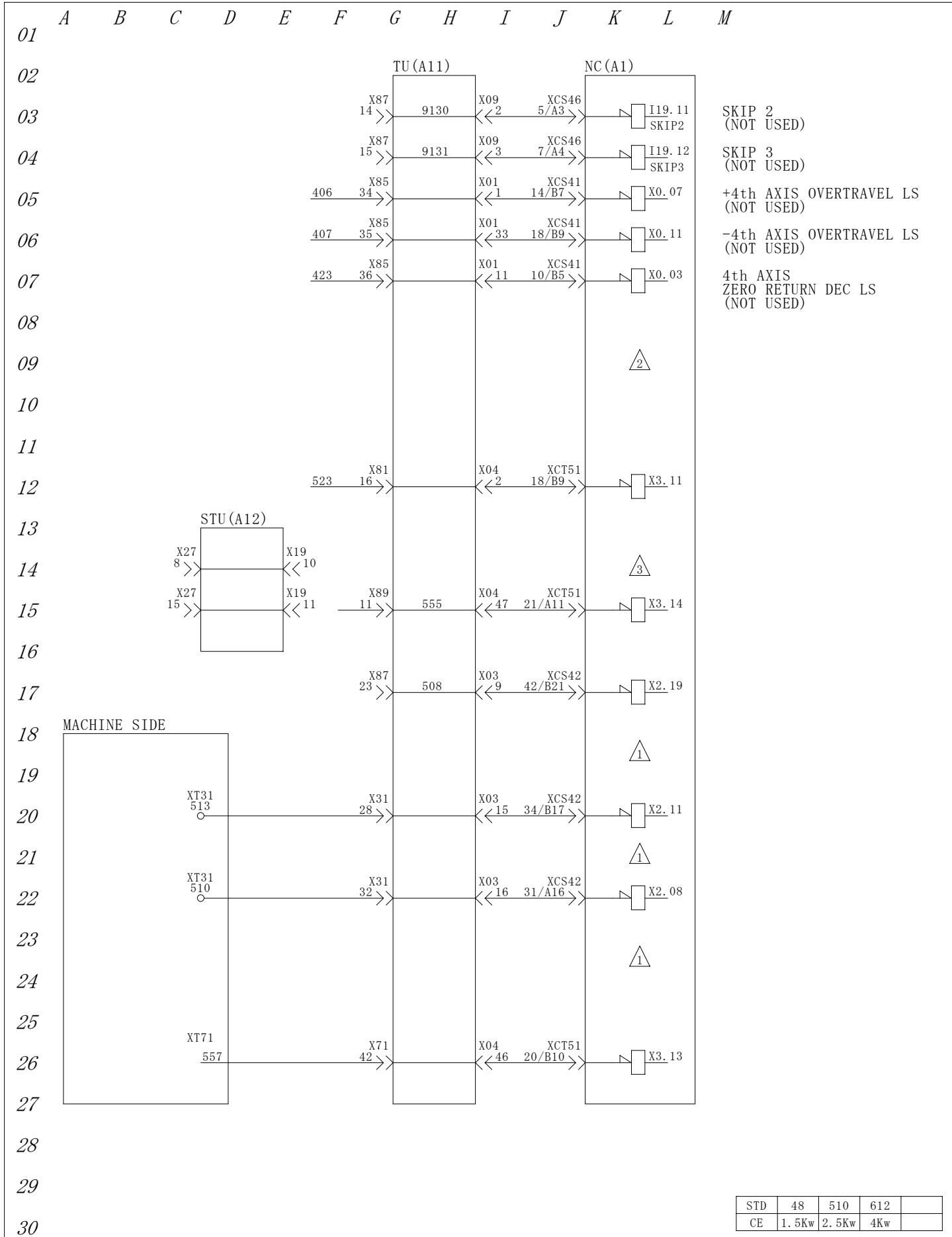

STD	48	510	612	
CE	1.5Kw	2.5Kw	4Kw	

△		APR' D BY	CHK' D BY	DRWN BY	TITLE
△		99/11/30	99/11/30	99/11/30	PC INPUT SPARE
△	Edition Oct.10.'03 M.Okajima	Mazak YAMAZAKI MAZAK CORPORATION	T. Inoue	M Okajima	M Okajima
△	Edition May.06.'03 M.Okajima				
△	Edition Apr.07.'00 M.Okajima				
					DRWN NO. 676 001 47013, 0

This product is subject to all the applicable Japanese Foreign Exchange and Foreign Trade Law.
 本品は『外国為替及び外国貿易法』に該当しますので外国に輸出する場合には同法に基づく許可を必要とします。

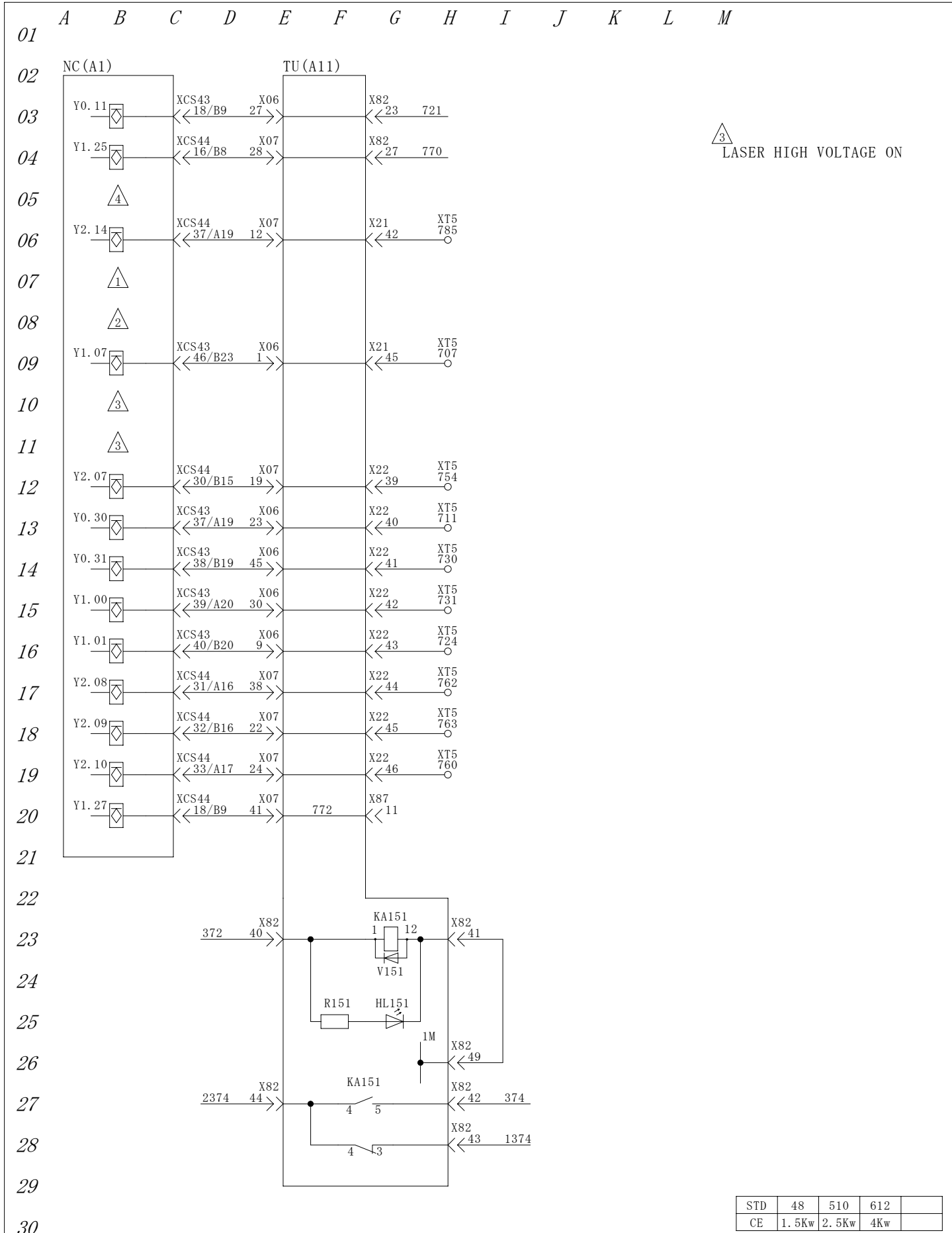

\triangle 3
LASER HIGH VOLTAGE ON

STD	48	510	612	
CE	1.5Kw	2.5Kw	4Kw	

\triangle Edition Jun.03.'04 M.Okajima \triangle Edition Jul.26.'01 M.Okajima \triangle Edition Aug.10.'00 M.Okajima \triangle Edition Apr.07.'00 M.Okajima	 YAMAZAKI MAZAK CORPORATION	APR'D BY	CHK'D BY	DRWN BY	TITLE
		99/11/30	99/11/30	99/11/30	PC OUTPUT SPARE
		T. Inoue	M Okajima	M Okajima	DRWN NO.
		676 001 47024, 0			

This product is subject to all the applicable Japanese Foreign Exchange and Foreign Trade Law.
 本品は『外国為替及び外国貿易法』に該当しますので外国に輸出する場合には同法に基づく許可を必要とします。

	A	B	C	D	E	F	G	H	I	J	K	L	M
01													
02							TU (A11)						
03							X81 9138 17 >>					X88 << 3	
04							X81 9139 18 >>					X88 << 4	
05							X81 9140 19 >>					X88 << 5	
06							X82 9141 29 >>					X88 << 6	
07							X82 9142 30 >>					X88 << 7	
08							X82 9143 31 >>					X88 << 8	
09							X82 9144 32 >>					X88 << 9	
10							X82 9145 45 >>					X88 << 10	
11							X82 9146 46 >>					X88 << 11	
12							X84 9151 19 >>					X87 << 43	
13							X84 9152 20 >>					X87 << 44	
14							X84 9153 21 >>					X87 << 45	
15							X84 9162 30 >>					X87 << 46	
16							X84 9163 31 >>					X87 << 47	
17							X84 9164 32 >>					X87 << 48	
18							X84 9150 48 >>					X87 << 42	
19							X85 9175 18 >>					X88 << 24	
20							X85 9172 38 >>					X88 << 21	
21							X85 9173 39 >>					X88 << 22	
22							X85 9174 40 >>					X88 << 23	
23							X21 9176 14 >>					X88 << 25	
24							X21 9177 15 >>					X88 << 26	
25							X21 9178 16 >>					X88 << 27	
26							X87 19 >>	414				X01 << 23	
27							X22 4 >>	477				X02 << 46	
28							X22 14 >>	474				X02 << 31	
29							X22 15 >>	475				X02 << 47	
30													

STD	48	510	612	
CE	1.5Kw	2.5Kw	4Kw	

	 <small>YAMAZAKI MAZAK CORPORATION</small>	APR' D BY	CHK' D BY	DRWN BY	TITLE
		99/11/30	99/11/30	99/11/30	TU SPARE
		T. Inoue	M Okajima	M Okajima	DRWN NO. 676 001 47030, 0

This product is subject to all the applicable Japanese Foreign Exchange and Foreign Trade Law.
 本品は『外国為替及び外国貿易法』に該当しますので外国に輸出する場合には同法に基づく許可を必要とします。

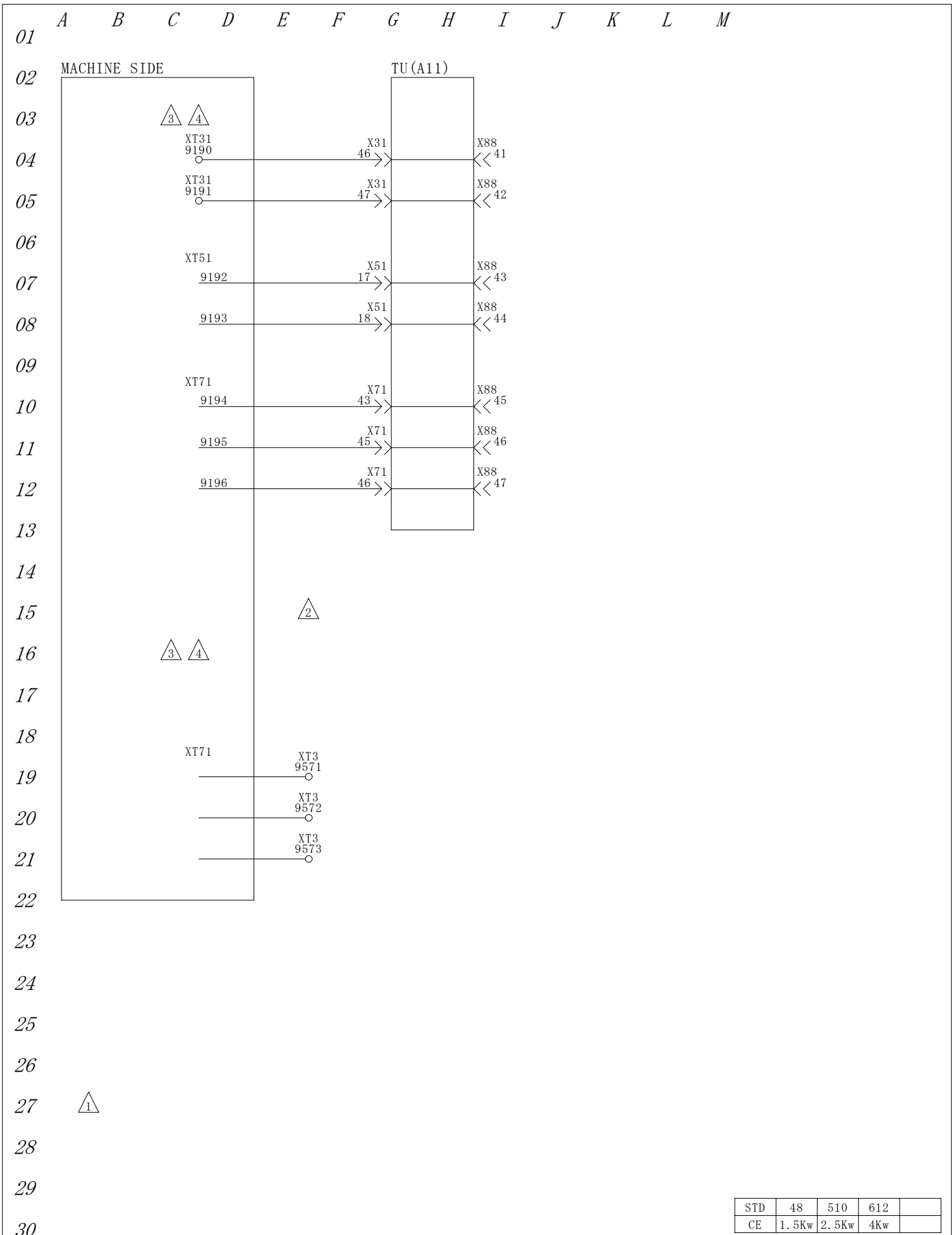

STD	48	510	612	
CE	1.5Kw	2.5Kw	4Kw	

△ △ Edition Oct.10.'03 M.Okajima △ Edition Oct.11.'00 M.Okajima △ Edition Aug.10.'00 M.Okajima △ Edition Mar.28.'00 M.Okajima	 YAMAZAKI MAZAK CORPORATION	APR'D BY	CHK'D BY	DRWN BY	TITLE
		99/11/30	99/11/30	99/11/30	XT31, 51, 71 SPARE
		T. Inoue	M Okajima	M Okajima	DRWN NO.
		676 001 47054, 0			

This product is subject to all the applicable Japanese Foreign Exchange and Foreign Trade Law.
 本品は『外国為替及び外国貿易法』に該当しますので外国に輸出する場合には同法に基づく許可を必要とします。

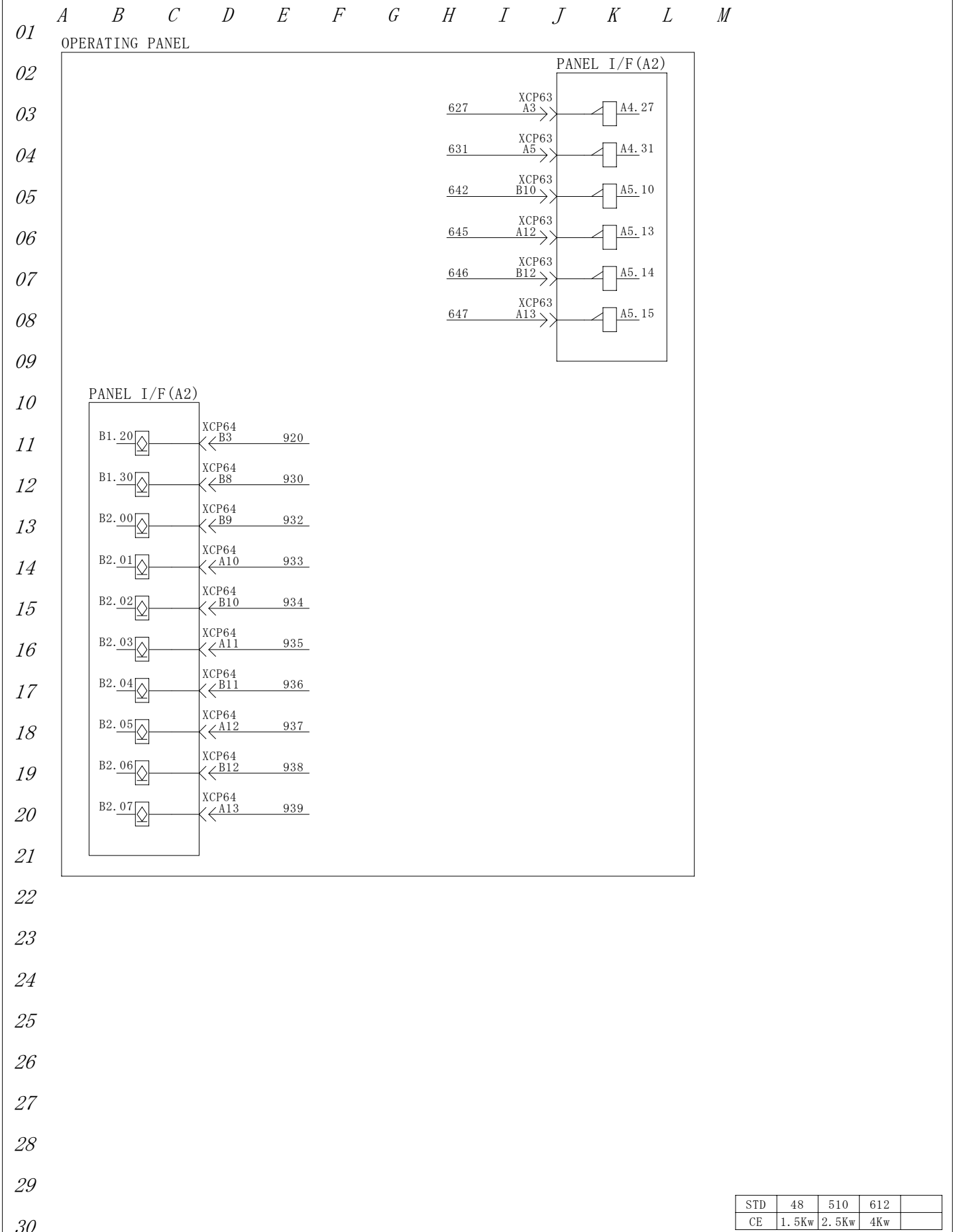

STD	48	510	612	
CE	1.5Kw	2.5Kw	4Kw	

 YAMAZAKI MAZAK CORPORATION	APR'D BY	CHK'D BY	DRWN BY	TITLE
	99/11/30	99/11/30	99/11/30	OPERATING PANEL SPARE
	T. Inoue	M Okajima	M Okajima	DRWN NO. 676 001 47070, 0

This product is subject to all the applicable Japanese Foreign Exchange and Foreign Trade Law.
 本品は『外国為替及び外国貿易法』に該当しますので外国に輸出する場合には同法に基づく許可を必要とします。

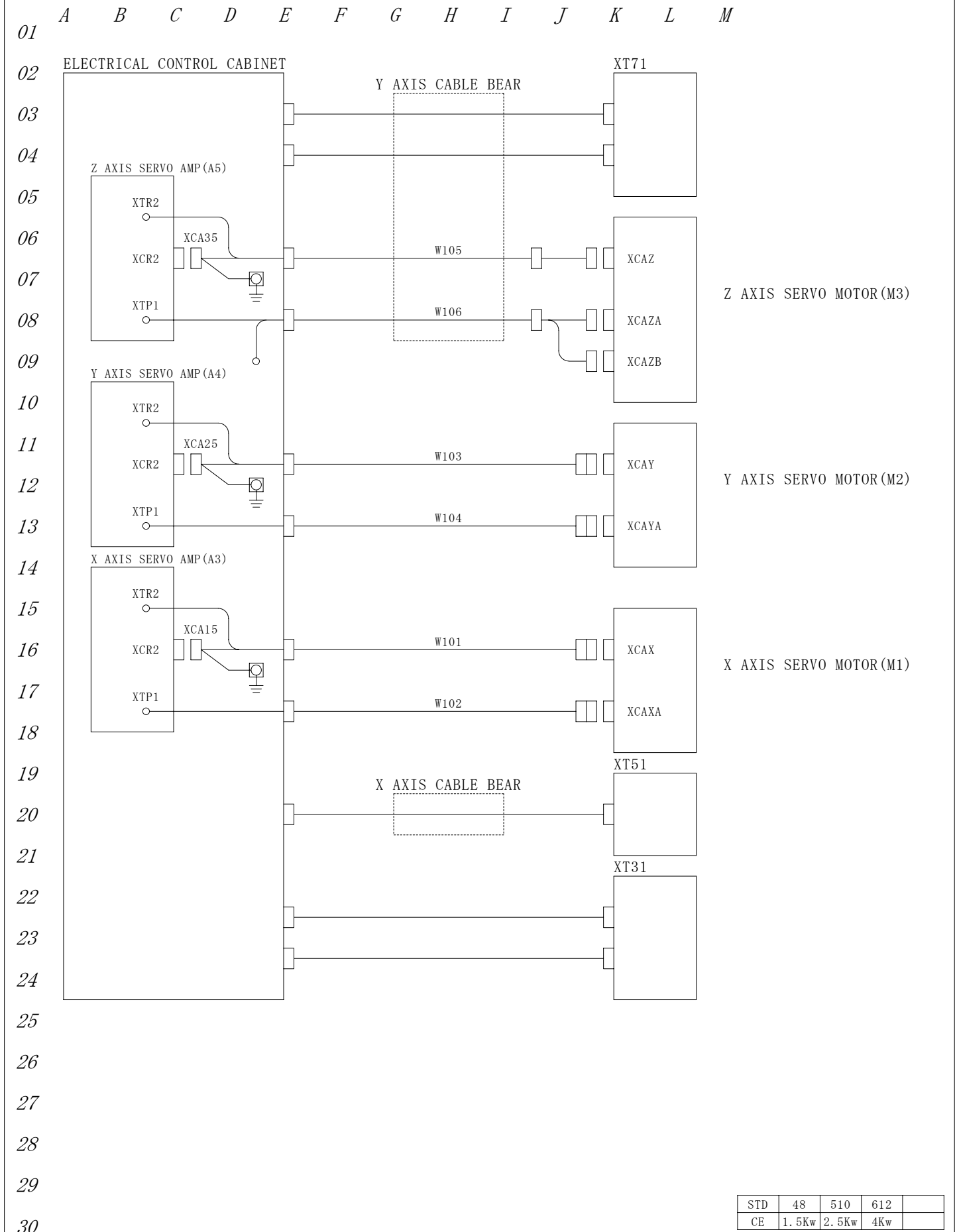



STD	48	510	612	
CE	1.5Kw	2.5Kw	4Kw	

	APR'D BY	CHK'D BY	DRWN BY	TITLE
	99/11/30	99/11/30	99/11/30	CONTROL CABINET (1)
	T. Inoue	M Okajima	M Okajima	DRWN NO. 676 001 30110, 0

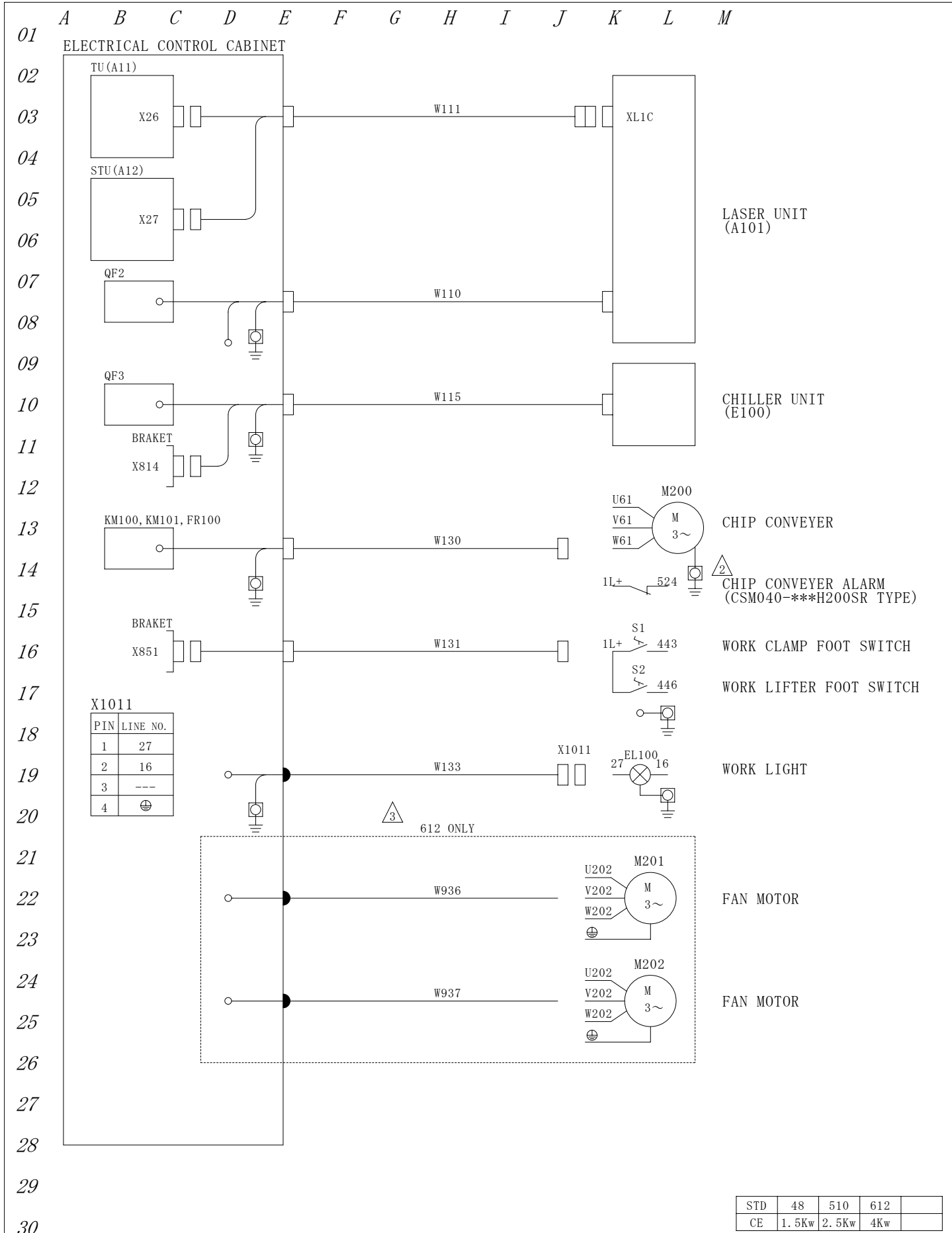

This product is subject to all the applicable Japanese Foreign Exchange and Foreign Trade Law. 本品は『外国為替及び外国貿易法』に該当しますので外国に輸出する場合には同法に基づく許可を必要とします。



△					
△					
△	Edition May.23'05 M.Okajima	 YAMAZAKI MAZAK CORPORATION	APR'D BY	CHK'D BY	DRWN BY
△	Edition May.06'03 M.Okajima		T.Inoue	M.Okajima	M.Okajima
△	Edition May.24'00 M.Okajima		TITLE		
			CONTROL CABINET (2)		
		DRWN NO. 676 001 30123, 0			

This product is subject to all the applicable Japanese Foreign Exchange and Foreign Trade Law.
 本品は『外国為替及び外国貿易法』に該当しますので外国に輸出する場合には同法に基づく許可を必要とします。

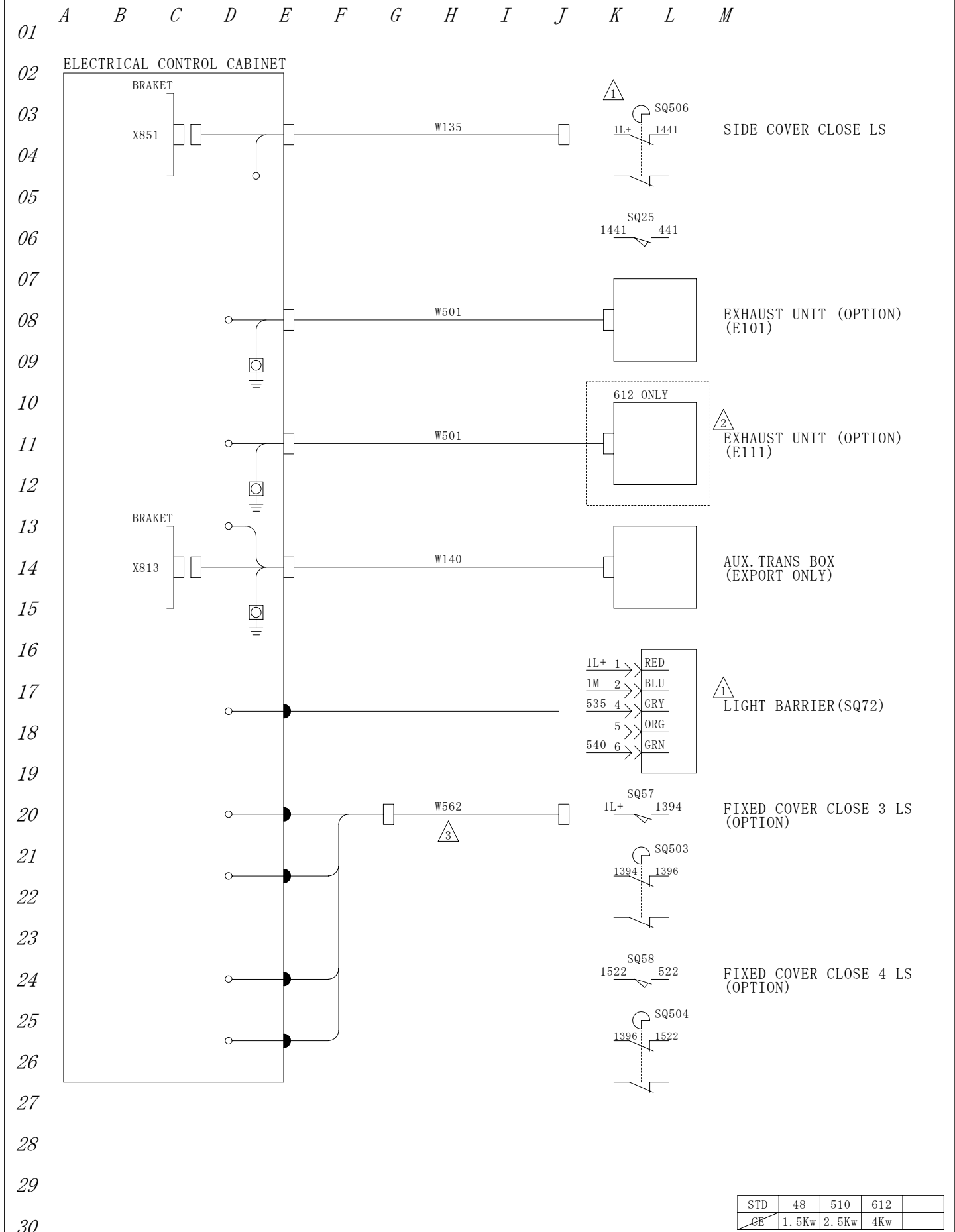

STD	48	510	612	
CE	1.5Kw	2.5Kw	4Kw	

△		 YAMAZAKI MAZAK CORPORATION	APR'D BY	CHK'D BY	DRWN BY	TITLE
△			99/11/30	99/11/30	99/11/30	CONTROL CABINET (3)
△	Edition Jun. 03. '04 M. Okajima		T. Inoue	M Okajima	M Okajima	
△	Edition Jul. 26. '01 M. Okajima					DRWN NO. 676 001 30133, 0
△	Edition May. 23. '00 M. Okajima					

This product is subject to all the applicable Japanese Foreign Exchange and Foreign Trade Law.
 本品は『外国為替及び外国貿易法』に該当しますので外国に輸出する場合には同法に基づく許可を必要とします。

	A	B	C	D	E	F	G	H	I	J	K	L	M	N	O	P
01																
02	XCA X		XCA Y		XCA Z		XL1 C									
03	PIN	LINE NO.	PIN	LINE NO.	PIN	LINE NO.	PIN	LINE NO.								
04	A	XPA1	A	YPA1	1	ZPA1	A	311								
05	B	XPA2	B	YPA2	2	ZPA2	B	312								
06	C	XPB1	C	YPB1	3	ZPB1	C	320								
07	D	XPB2	D	YPB2	4	ZPB2	D	314								
08	E	XPZ1	E	YPZ1	5	ZPZ1	E	315								
09	F	XPZ2	F	YPZ2	6	ZPZ2	F	319								
10	G	XSG	G	YSG	7	ZC11	G	316								
11	H	XVCC	H	YVCC	8	ZC12	H	317								
12	J	XFG	J	YFG	9	ZC21	J	1M								
13	K	XC11	K	YC11	10	ZC22	K	---								
14	L	XC12	L	YC12	11	ZC31	L	---								
15	M	XC21	M	YC21	12	ZC32	M	---								
16	N	XC22	N	YC22	13	ZVCC	N	---								
17	P	XC31	P	YC31	14	ZSG	O	480								
18	R	XC32	R	YC32	15	ZFG	P	481								
19	S	XTH1	S	YTH1			Q	482								
20	T	XTH2	T	YTH2			R	483								
21							S	484								
22							T	485								
23							U	486								
24							V	487								
25							W	490								
26							X	491								
27							Y	492								
28							Z	493								
29							a	494								
30							b	495								
							c	496								
							d	497								
							e	500								
							f	501								
							g	502								
							h	503								
							j	504								
							k	505								
							m	506								
							n	507								
							p	1L+								
							q	1M								
							r	---								
							s	---								
							t	DAP1								
							u	DAN1								
							v	LPP1								
							w	LPG1								
							x	---								
							y	ADP1								
							z	ADN1								

STD	48	510	612	
CE	1.5Kw	2.5Kw	4Kw	

△		 YAMAZAKI MAZAK CORPORATION	APR' D BY	CHK' D BY	DRWN BY	TITLE
△			99/11/30	99/11/30	99/11/30	CONTROL CABINET (4)
△			T. Inoue	M Okaji ma	M Okaji ma	
△						DRWN NO.
△						676 001 30150, 0

This product is subject to all the applicable Japanese Foreign Exchange and Foreign Trade Law.
 本品は『外国為替及び外国貿易法』に該当しますので外国に輸出する場合には同法に基づく許可を必要とします。

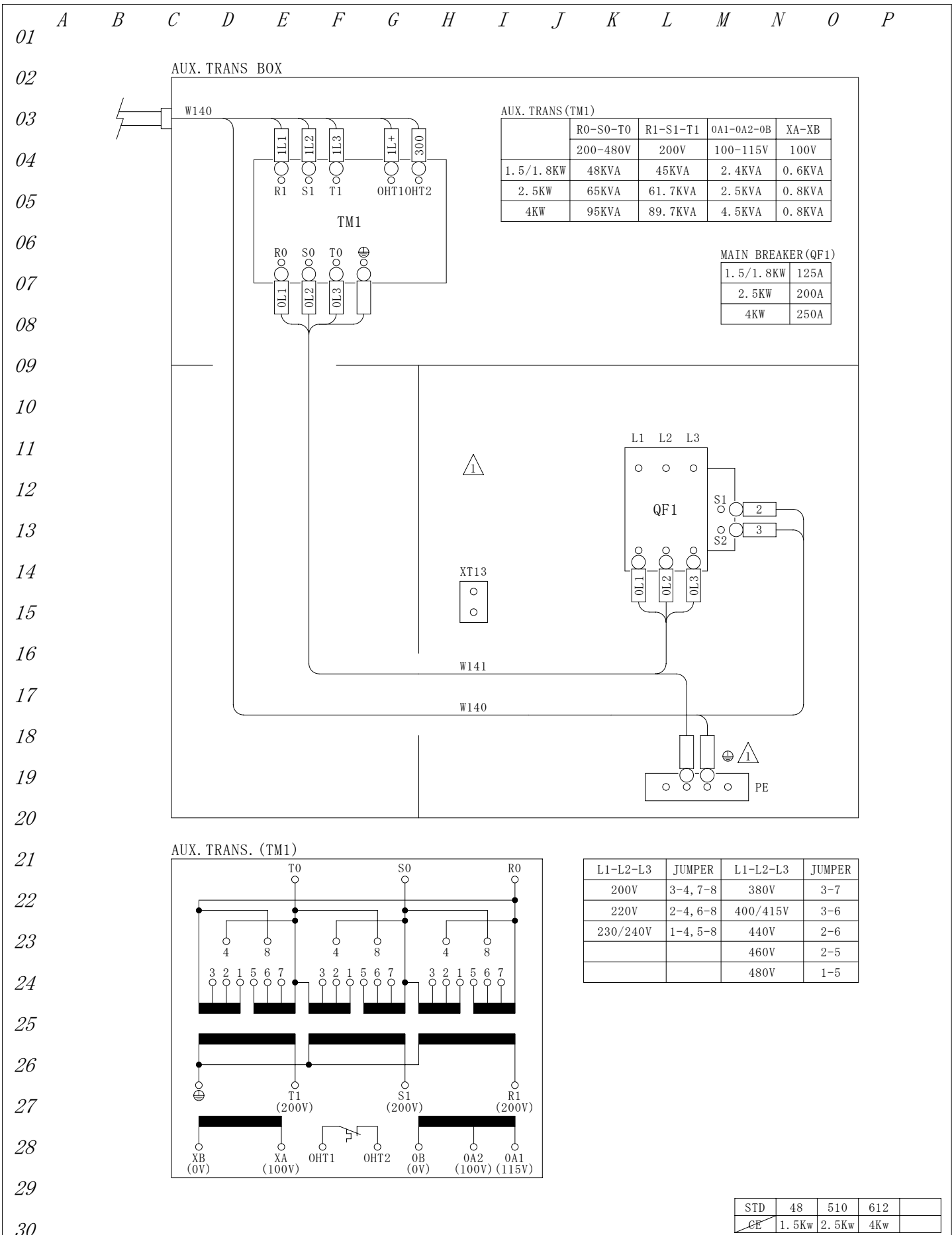

AUX. TRANS (TM1)

	R0-S0-T0	R1-S1-T1	0A1-0A2-0B	XA-XB
	200-480V	200V	100-115V	100V
1.5/1.8KW	48KVA	45KVA	2.4KVA	0.6KVA
2.5KW	65KVA	61.7KVA	2.5KVA	0.8KVA
4KW	95KVA	89.7KVA	4.5KVA	0.8KVA

MAIN BREAKER (QF1)

1.5/1.8KW	125A
2.5KW	200A
4KW	250A

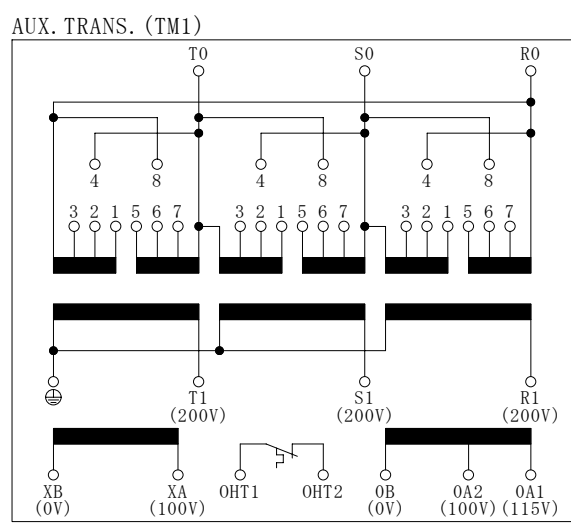

L1-L2-L3	JUMPER	L1-L2-L3	JUMPER
200V	3-4, 7-8	380V	3-7
220V	2-4, 6-8	400/415V	3-6
230/240V	1-4, 5-8	440V	2-6
		460V	2-5
		480V	1-5

STD	48	510	612
CE	1.5Kw	2.5Kw	4Kw

△		 YAMAZAKI MAZAK CORPORATION	APR' D BY	CHK' D BY	DRWN BY	TITLE
△			01/07/30	01/07/30	01/07/30	AUX. TRANS BOX
△			T. Inoue	M Okaji ma	M Okaji ma	
△	Edition Jan.18.'02 M.Okajima		DRWN NO. 676 001 30161,0			

This product is subject to all the applicable Japanese Foreign Exchange and Foreign Trade Law.
 本品は『外国為替及び外国貿易法』に該当しますので外国に輸出する場合には同法に基づく許可を必要とします。

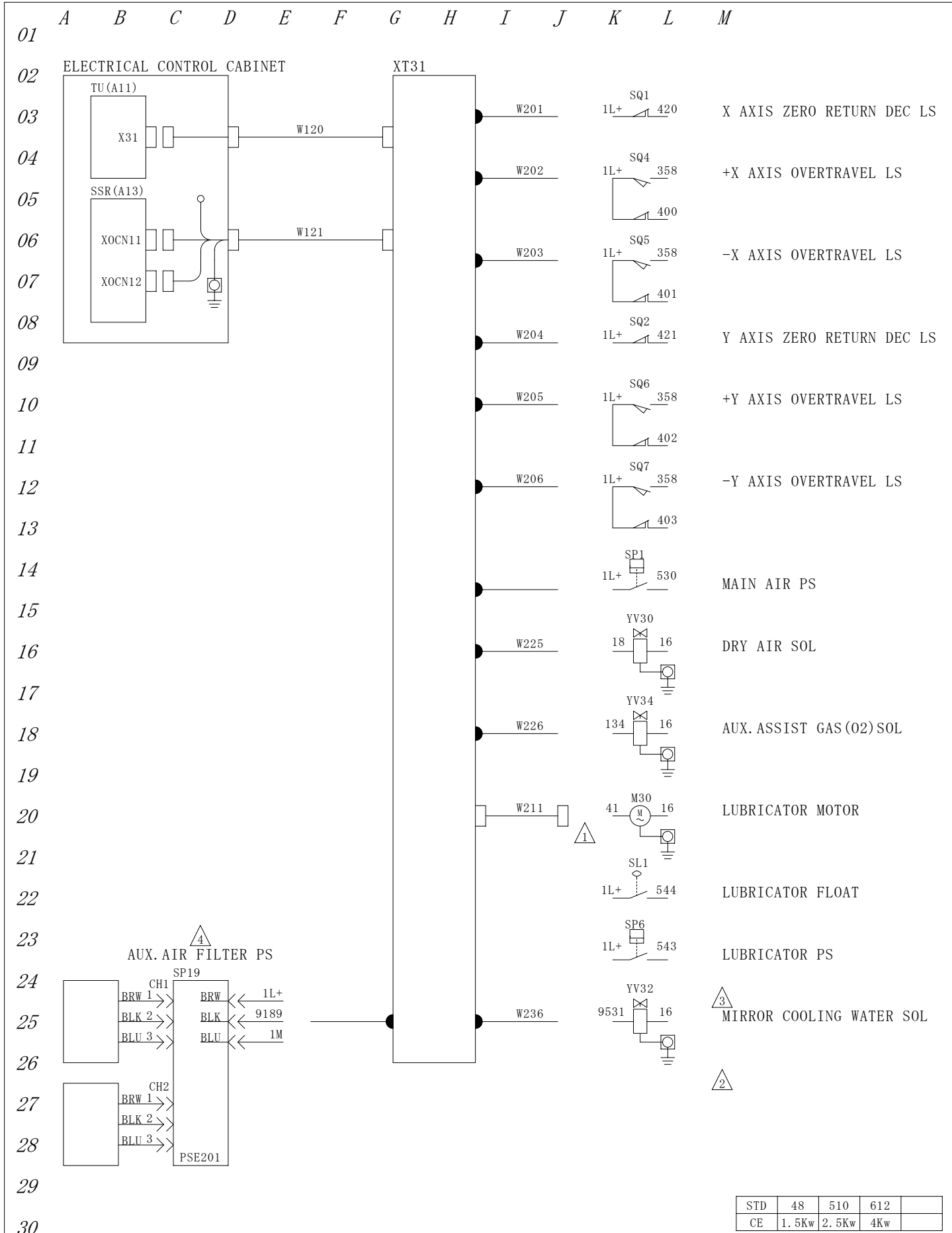

STD	48	510	612	
CE	1.5Kw	2.5Kw	4Kw	

△	APR'D BY	CHK'D BY	DRWN BY	TITLE
△	99/11/30	99/11/30	99/11/30	XT31 (1)
△	T. Inoue	M Okajima	M Okajima	DRWN NO. 676 001 30314, 0
△	Edition Oct. 10. '03 M. Okajima			
△	Edition Aug. 13. '00 M. Okajima			
△	Edition May. 23. '00 M. Okajima			
△	Edition Mar. 28. '00 M. Okajima			

This product is subject to all the applicable Japanese Foreign Exchange and Foreign Trade Law.
 本品は『外国為替及び外国貿易法』に該当しますので外国に輸出する場合には同法に基づく許可を必要とします。

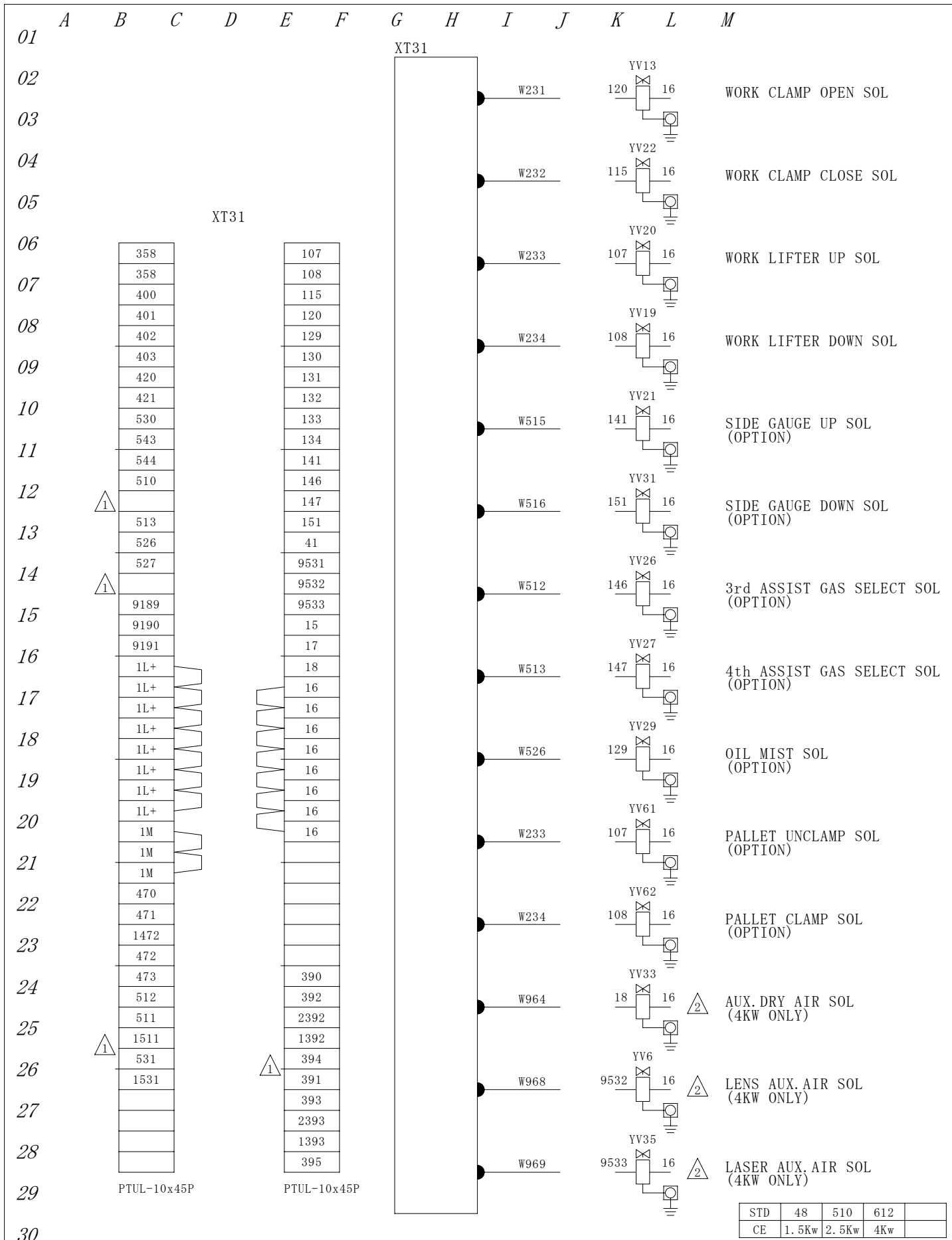

△		 YAMAZAKI MAZAK CORPORATION	APR'D BY	CHK'D BY	DRWN BY	TITLE
△			99/11/30	99/11/30	99/11/30	XT31 (2)
△	Edition Oct.10.'03 M.Okajima		T. Inoue	M Okajima	M Okajima	DRWN NO.
△	Edition Apr.07.'00 M.Okajima					676 001 30322, 0

This product is subject to all the applicable Japanese Foreign Exchange and Foreign Trade Law.
 本品は『外国為替及び外国貿易法』に該当しますので外国に輸出する場合には同法に基づく許可を必要とします。

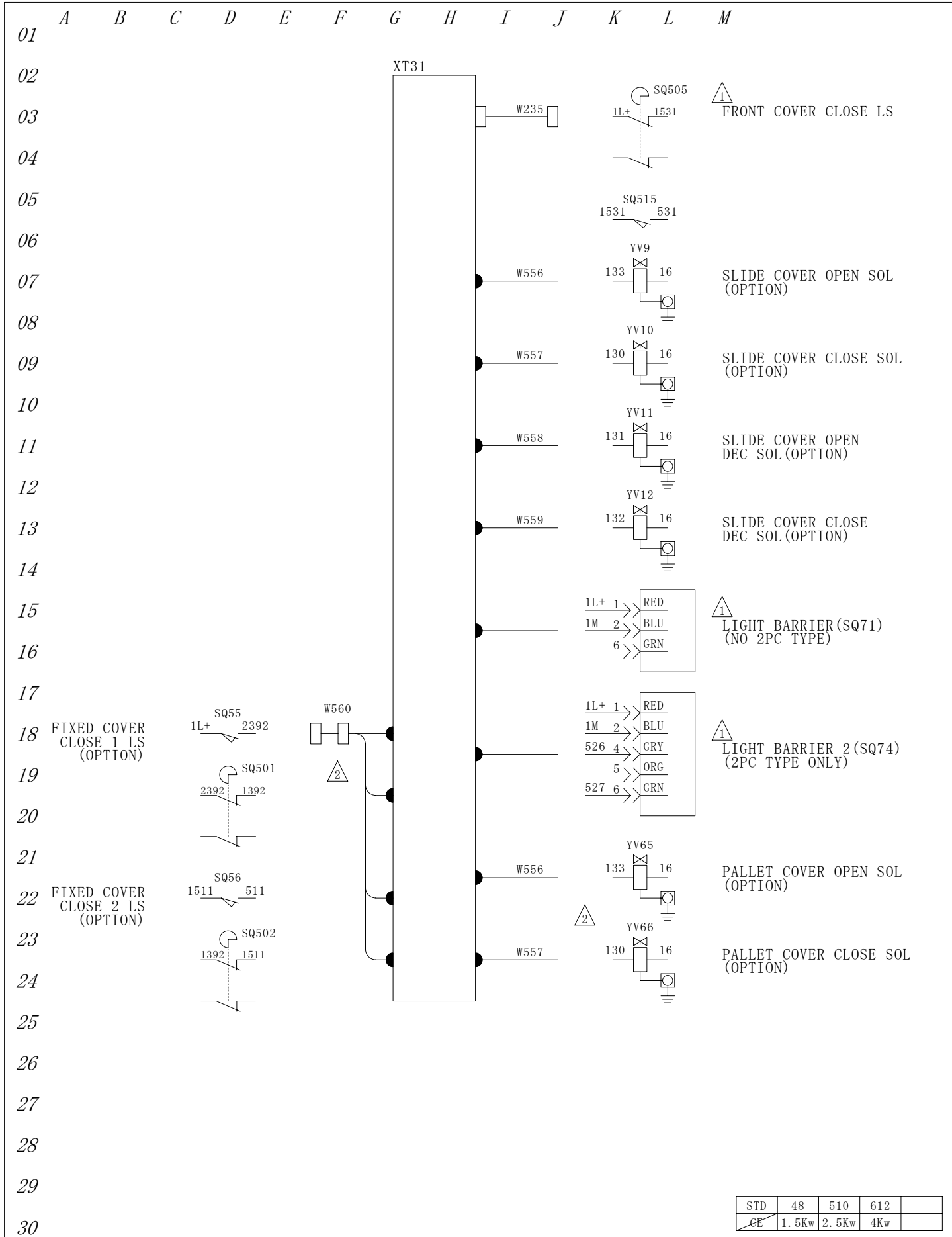

△		 YAMAZAKI MAZAK CORPORATION	APR' D BY	CHK' D BY	DRWN BY	TITLE
△			99/11/30	99/11/30	99/11/30	XT31 (3)
△			T. Inoue	M Okajima	M Okajima	DRWN NO.
△			676 001 30332, 0			

This product is subject to all the applicable Japanese Foreign Exchange and Foreign Trade Law.
 本品は『外国為替及び外国貿易法』に該当しますので外国に輸出する場合には同法に基づく許可を必要とします。

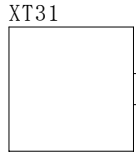
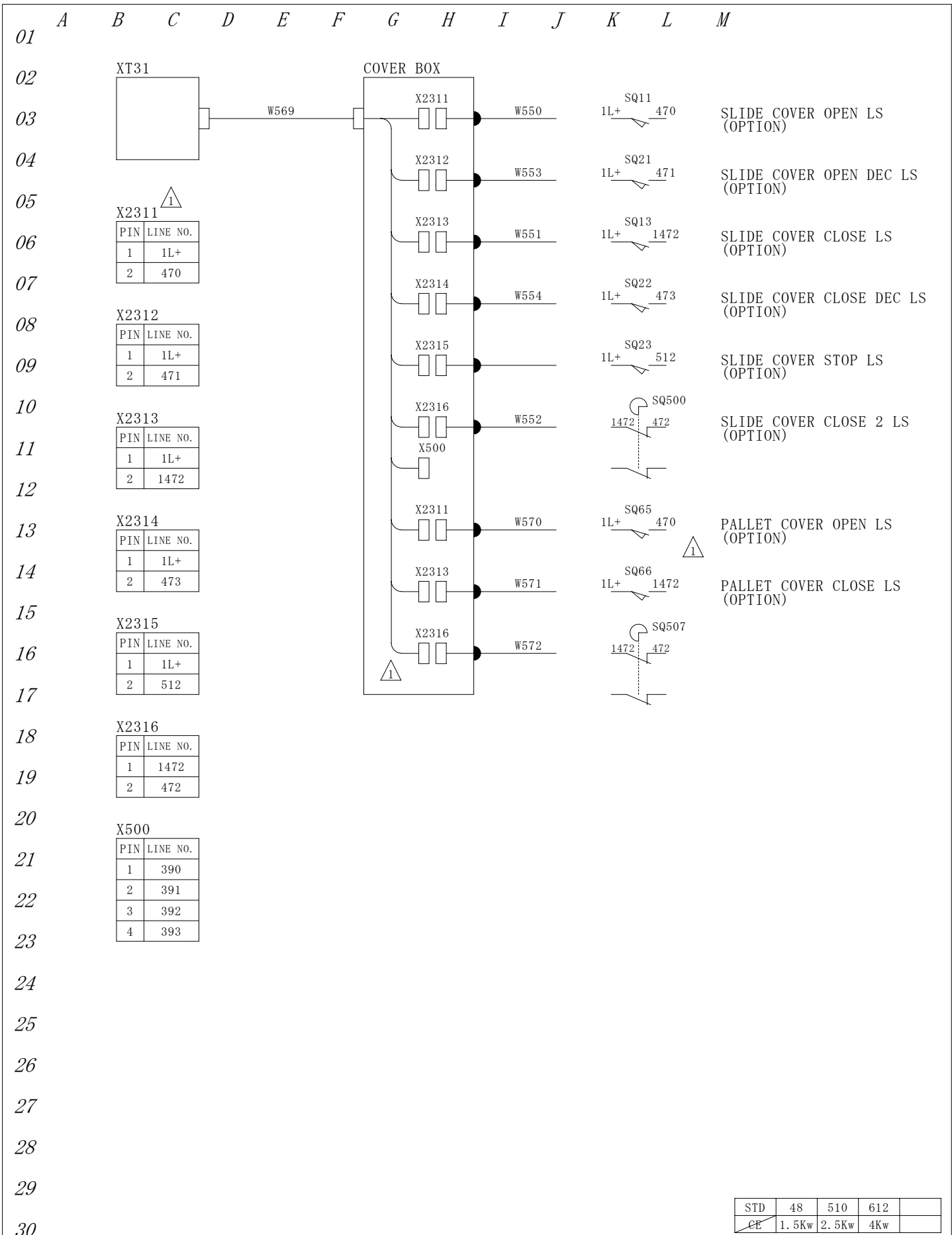

COVER BOX

X2311

PIN	LINE NO.
1	1L+
2	470

X2312

PIN	LINE NO.
1	1L+
2	471

X2313

PIN	LINE NO.
1	1L+
2	1472

X2314

PIN	LINE NO.
1	1L+
2	473

X2315

PIN	LINE NO.
1	1L+
2	512

X2316

PIN	LINE NO.
1	1472
2	472

X500

PIN	LINE NO.
1	390
2	391
3	392
4	393

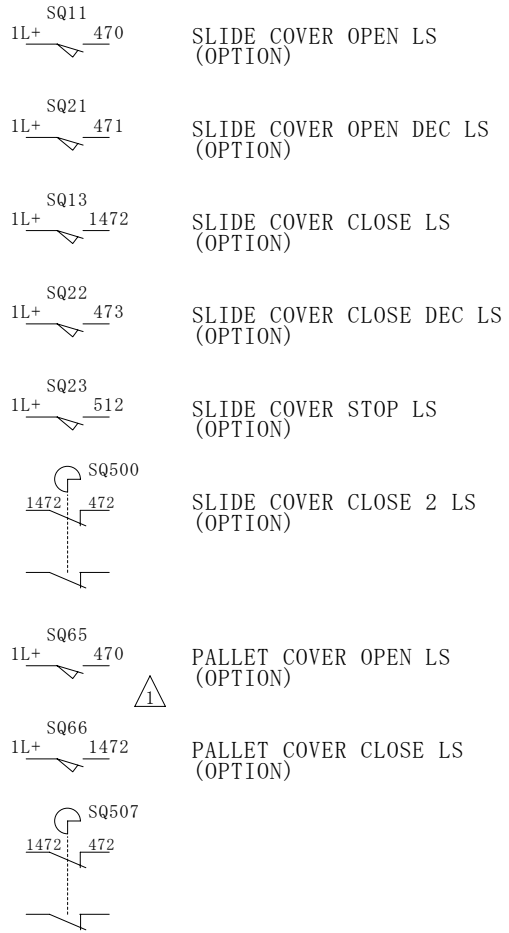



STD	48	510	612	
CE	1.5Kw	2.5Kw	4Kw	

APR'D BY	CHK'D BY	DRWN BY	TITLE
99/11/30	99/11/30	99/11/30	XT31 (4)
T. Inoue	M Okajima	M Okajima	DRWN NO. 676 001 30341, 0

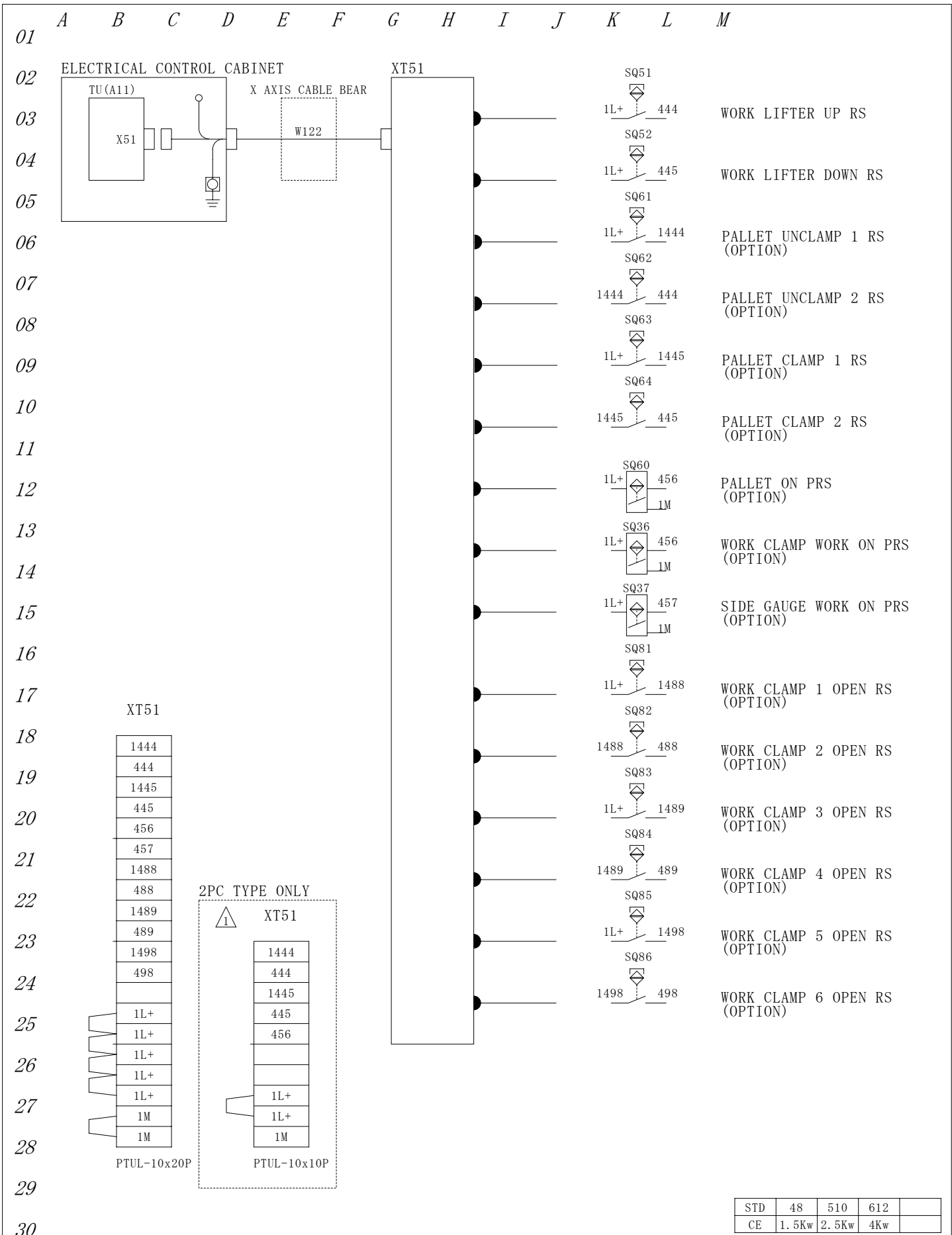

This product is subject to all the applicable Japanese Foreign Exchange and Foreign Trade Law.
 本品は『外国為替及び外国貿易法』に該当しますので外国に輸出する場合には同法に基づく許可を必要とします。



△		 YAMAZAKI MAZAK CORPORATION	APR'D BY	CHK'D BY	DRWN BY	TITLE
△			99/11/30	99/11/30	99/11/30	XT51
△			T. Inoue	M Okajima	M Okajima	
△	Edition Mar. 28. '00 M. Okajima					DRWN NO. 676 001 30511, 0

This product is subject to all the applicable Japanese Foreign Exchange and Foreign Trade Law.
 本品は『外国為替及び外国貿易法』に該当しますので外国に輸出する場合には同法に基づく許可を必要とします。

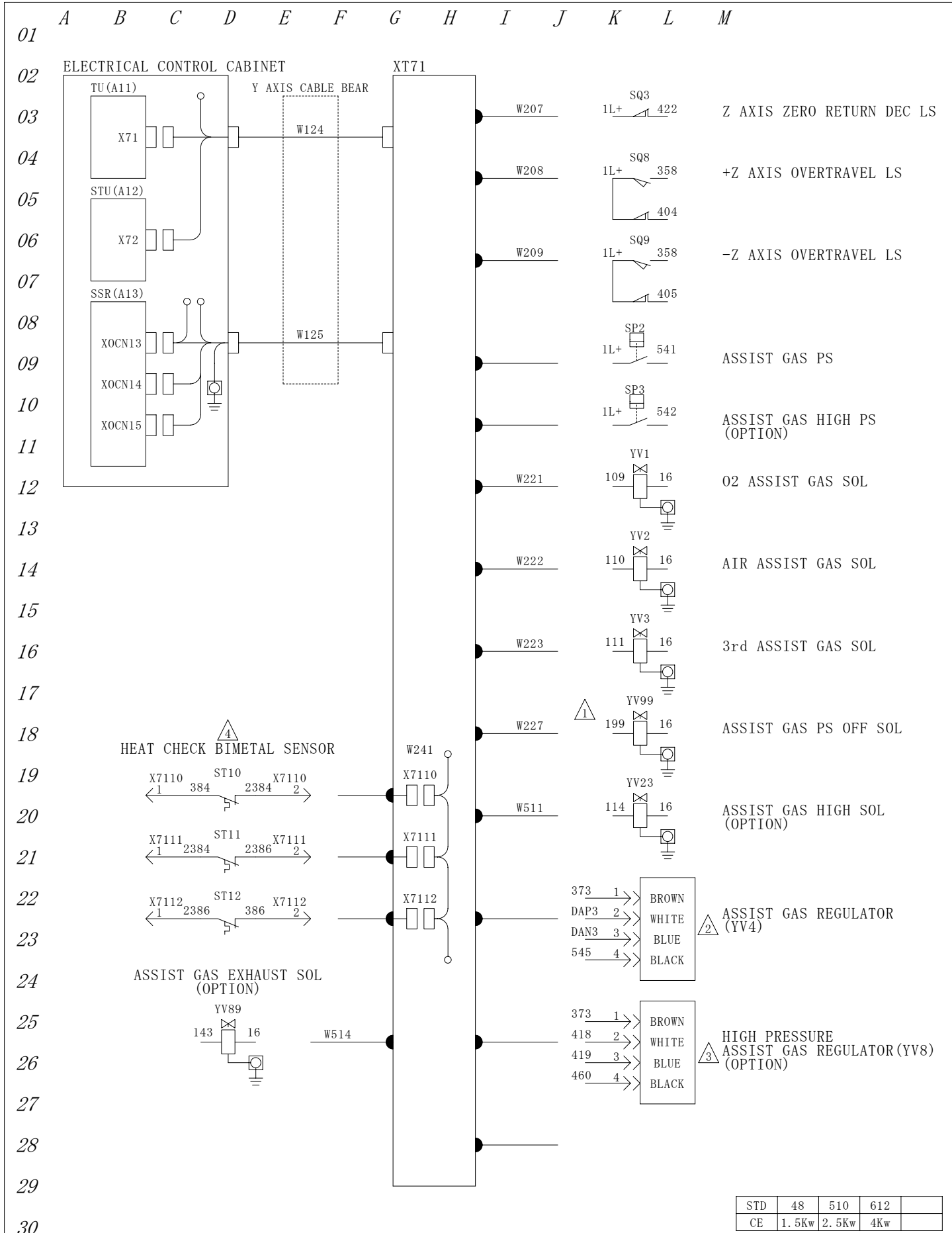

STD	48	510	612	
CE	1.5Kw	2.5Kw	4Kw	

△	Edition Jan.26.'04 M.Okajima	 YAMAZAKI MAZAK CORPORATION	APR'D BY	CHK'D BY	DRWN BY	TITLE
△	Edition Dec.19.'01 M.Okajima		99/11/30	99/11/30	99/11/30	XT71 (1)
△	Edition May.11.'01 M.Okajima		T. Inoue	M Okajima	M Okajima	DRWN NO.
△	Edition Mar.28.'00 M.Okajima		676 001 30714, 0			

This product is subject to all the applicable Japanese Foreign Exchange and Foreign Trade Law.
 本品は『外国為替及び外国貿易法』に該当しますので外国に輸出する場合には同法に基づく許可を必要とします。

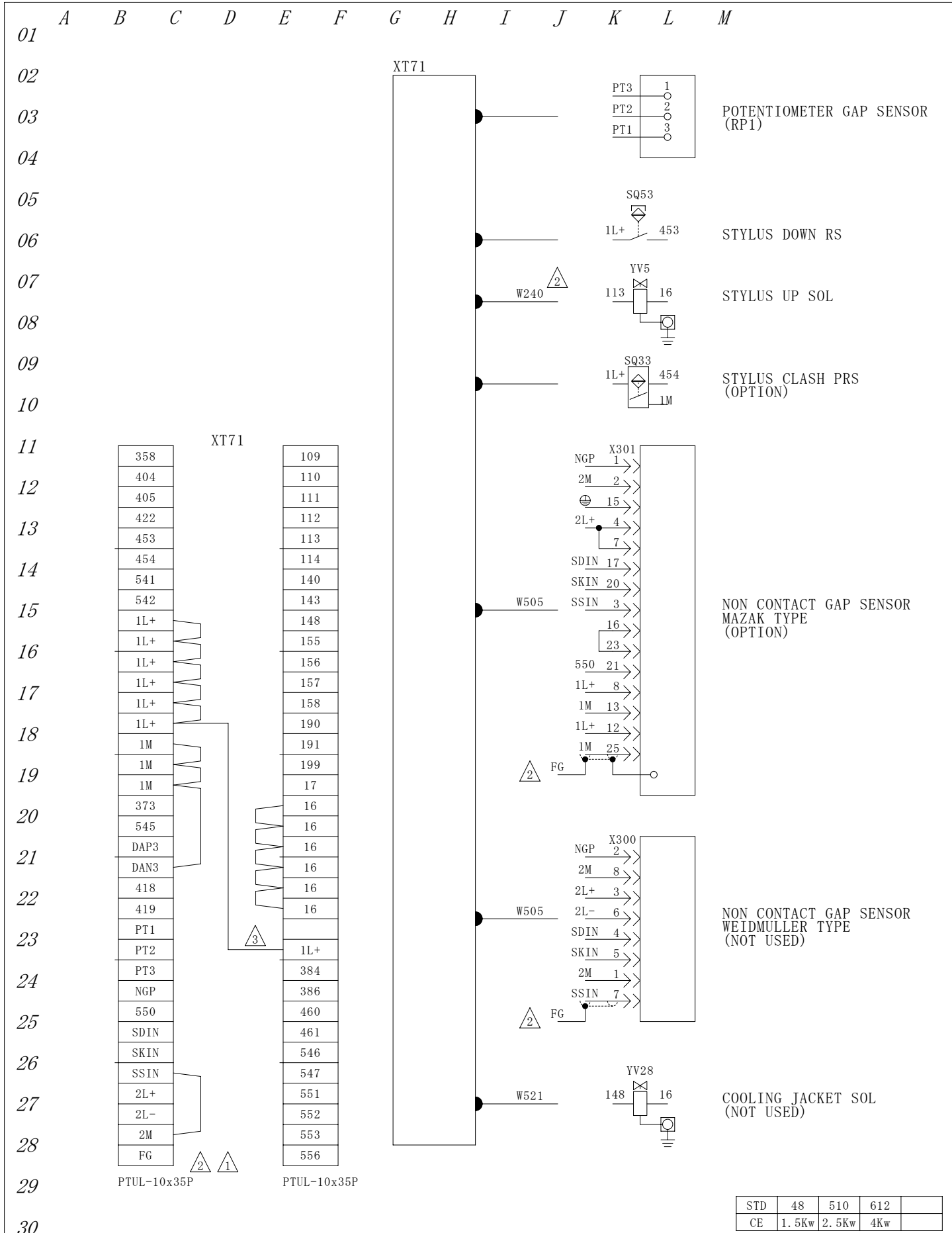

STD	48	510	612	
CE	1.5Kw	2.5Kw	4Kw	

▲ ▲ Edition Dec.19.'01 M.Okajima ▲ Edition Jul.26.'01 M.Okajima ▲ Edition Jul.31.'00 M.Okajima	 YAMAZAKI MAZAK CORPORATION	APR'D BY 99/11/30 T. Inoue	CHK'D BY 99/11/30 M Okajima	DRWN BY 99/11/30 M Okajima	TITLE XT71 (2) DRWN NO. 676 001 30723, 0
---	--------------------------------	----------------------------------	-----------------------------------	----------------------------------	--

This product is subject to all the applicable Japanese Foreign Exchange and Foreign Trade Law.
 本品は『外国為替及び外国貿易法』に該当しますので外国に輸出する場合には同法に基づく許可を必要とします。

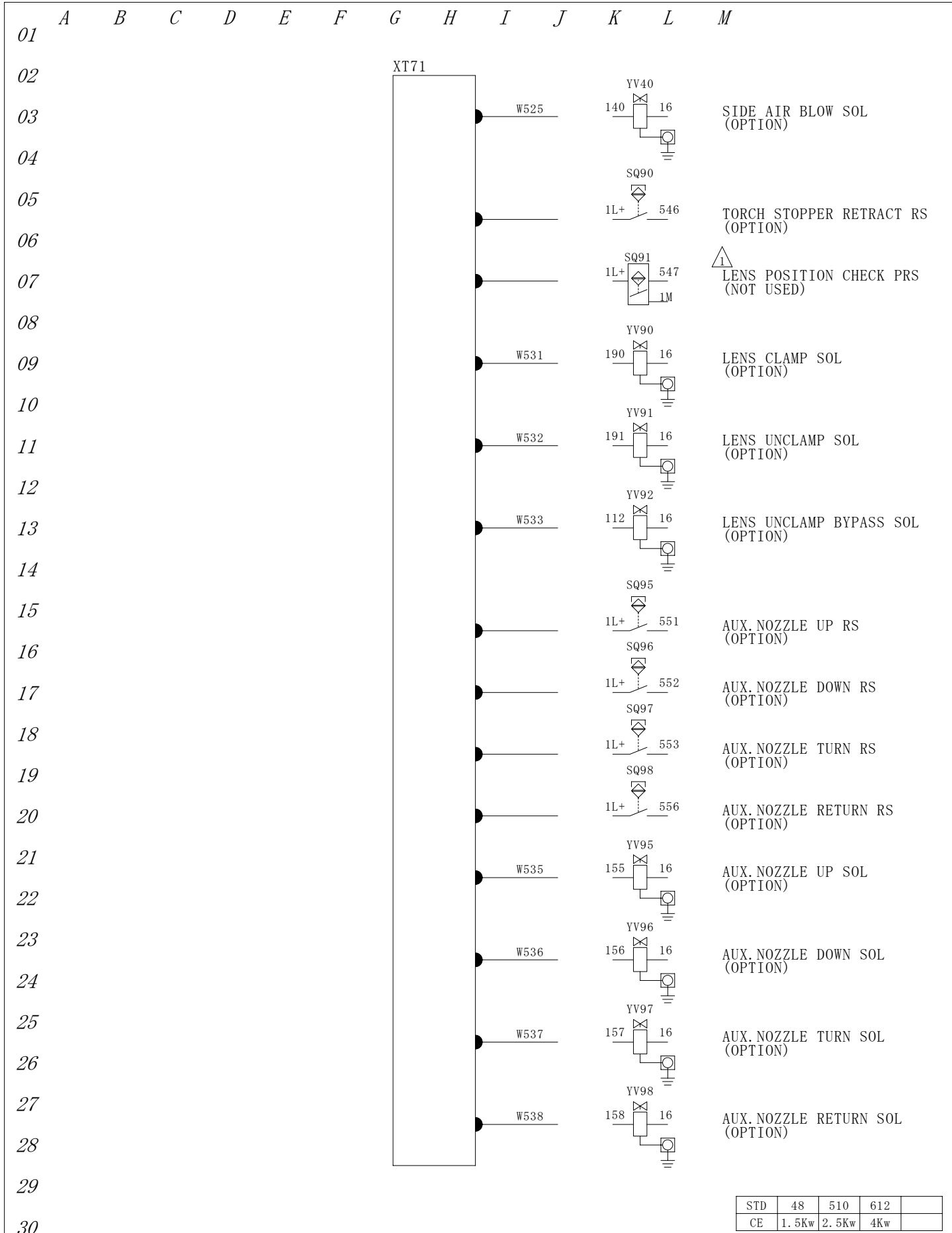

STD	48	510	612	
CE	1.5Kw	2.5Kw	4Kw	

△		 YAMAZAKI MAZAK CORPORATION	APR'D BY	CHK'D BY	DRWN BY	TITLE
△			99/11/30	99/11/30	99/11/30	XT71 (3)
△			T. Inoue	M Okajima	M Okajima	
△						DRWN NO. 676 001 30731, 0

This product is subject to all the applicable Japanese Foreign Exchange and Foreign Trade Law.
 本品は『外国為替及び外国貿易法』に該当しますので外国に輸出する場合には同法に基づく許可を必要とします。

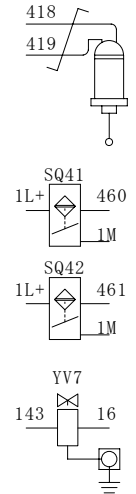
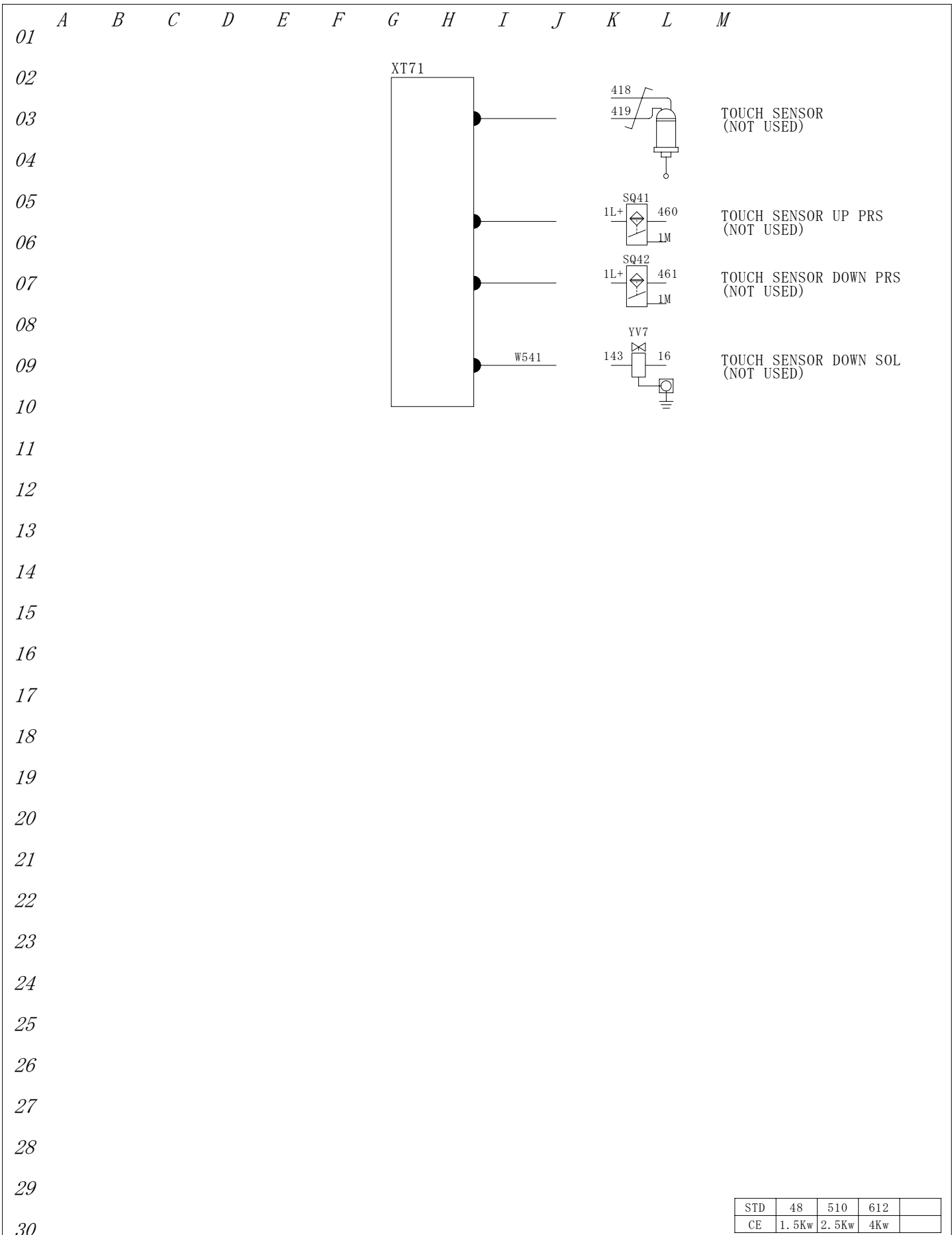

TOUCH SENSOR
(NOT USED)

TOUCH SENSOR UP PRS
(NOT USED)

TOUCH SENSOR DOWN PRS
(NOT USED)

TOUCH SENSOR DOWN SOL
(NOT USED)

STD	48	510	612	
CE	1.5Kw	2.5Kw	4Kw	

		 YAMAZAKI MAZAK CORPORATION	APR'D BY	CHK'D BY	DRWN BY	TITLE
			T. Inoue	M Okajima	M Okajima	XT71 (4)
						DRWN NO. 676 001 30740, 0

This product is subject to all the applicable Japanese Foreign Exchange and Foreign Trade Law.
 本品は『外国為替及び外国貿易法』に該当しますので外国に輸出する場合には同法に基づく許可を必要とします。

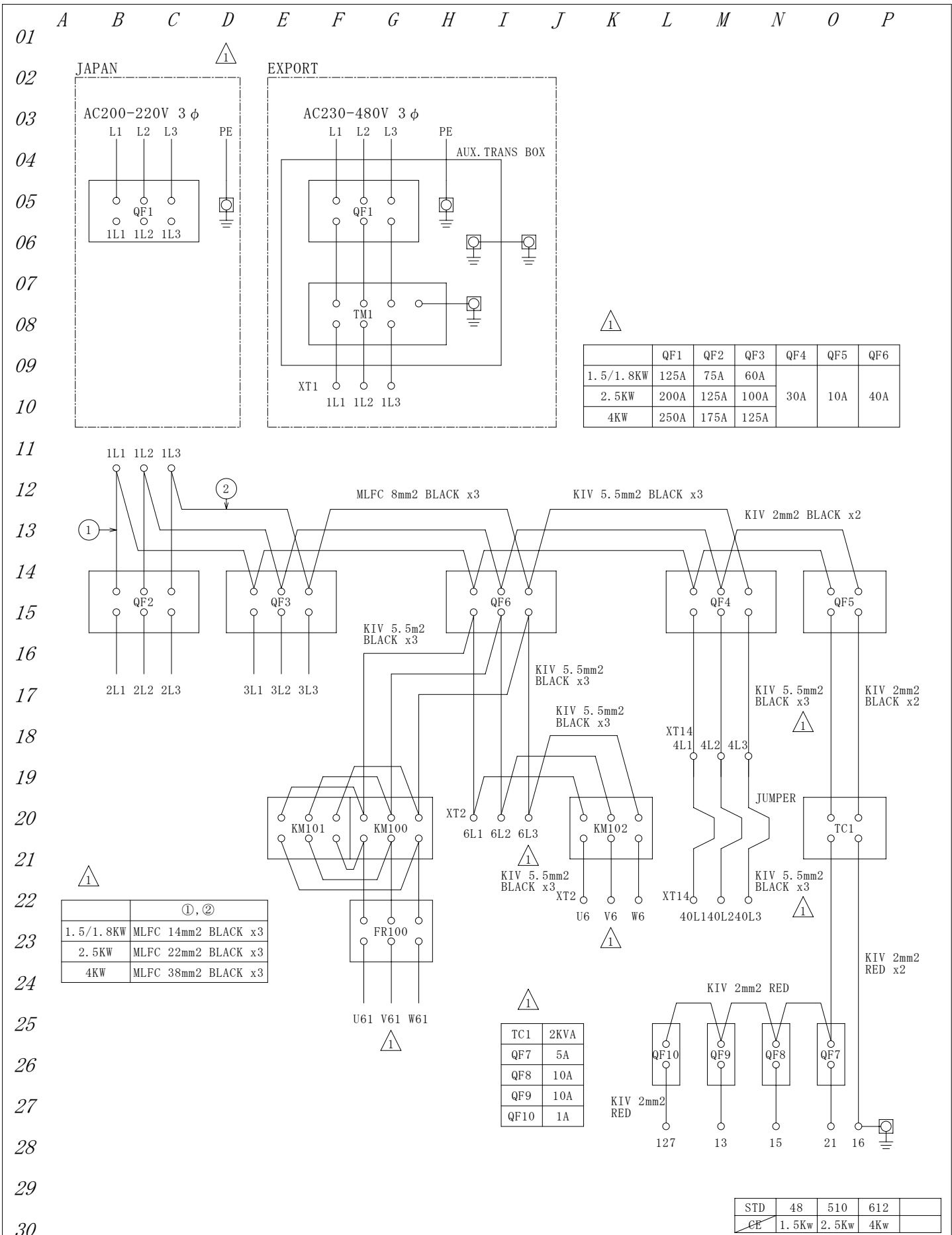

APR'D BY	CHK'D BY	DRWN BY	TITLE
99/11/30	99/11/30	99/11/30	POWER CIRCUIT CONNECTION (JAPAN, EXPORT)
T. Inoue	M Okajima	M Okajima	DRWN NO. 676 001 51011, 0

Mazak
YAMAZAKI MAZAK CORPORATION

Edition Jul.05.'01 M.Okajima

This product is subject to all the applicable Japanese Foreign Exchange and Foreign Trade Law.
 本品は『外国為替及び外国貿易法』に該当しますので外国に輸出する場合には同法に基づく許可を必要とします。

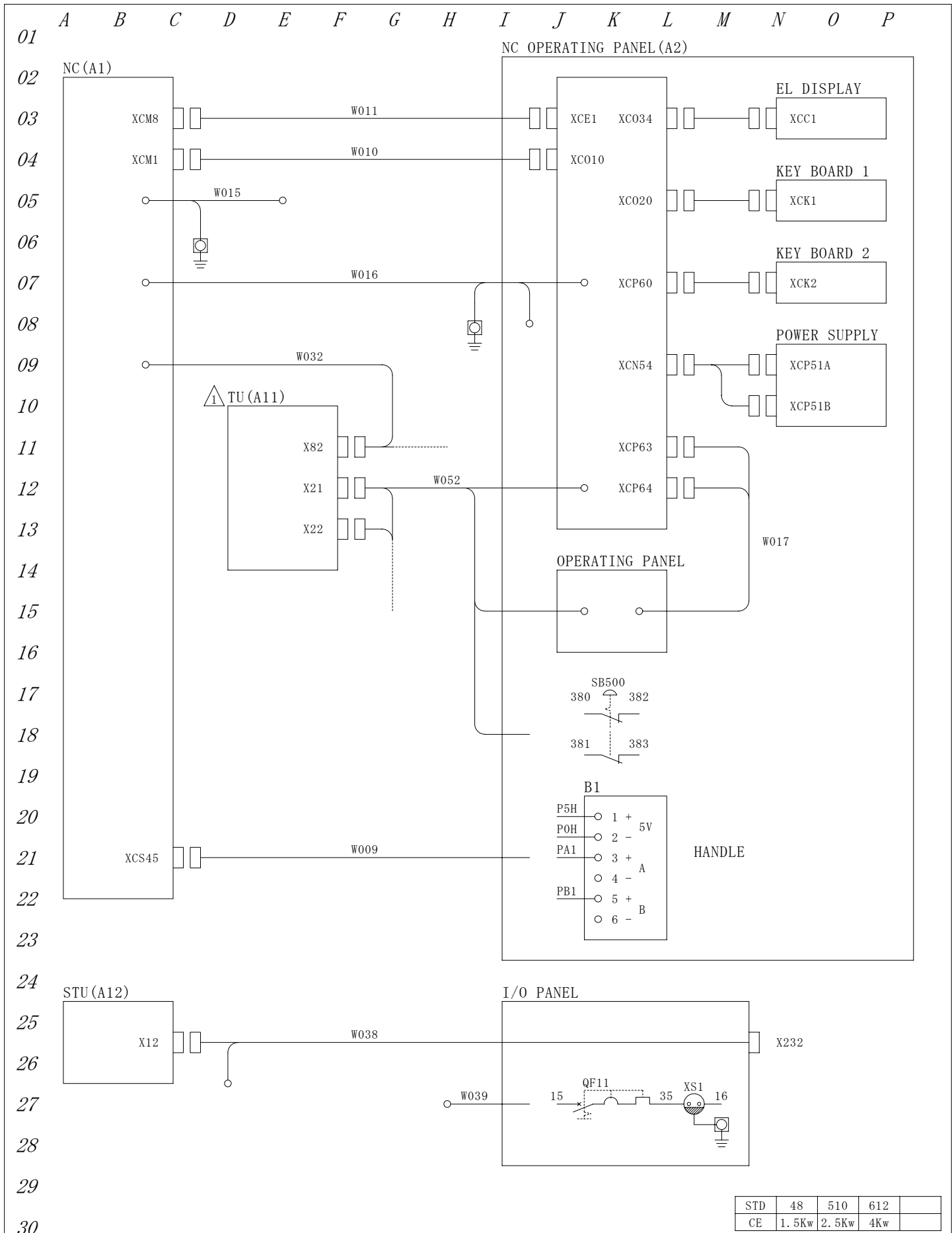

STD	48	510	612	
CE	1.5Kw	2.5Kw	4Kw	

△		 YAMAZAKI MAZAK CORPORATION	APR'D BY	CHK'D BY	DRWN BY	TITLE
△			99/11/30	99/11/30	99/11/30	CABINET
△			T. Inoue	M Okajima	M Okajima	CABLE CONNECTION (1)
△	Edition May.11.'01 M.Okajima					DRWN NO. 676 001 51101,0

This product is subject to all the applicable Japanese Foreign Exchange and Foreign Trade Law.
 本品は『外国為替及び外国貿易法』に該当しますので外国に輸出する場合には同法に基づく許可を必要とします。

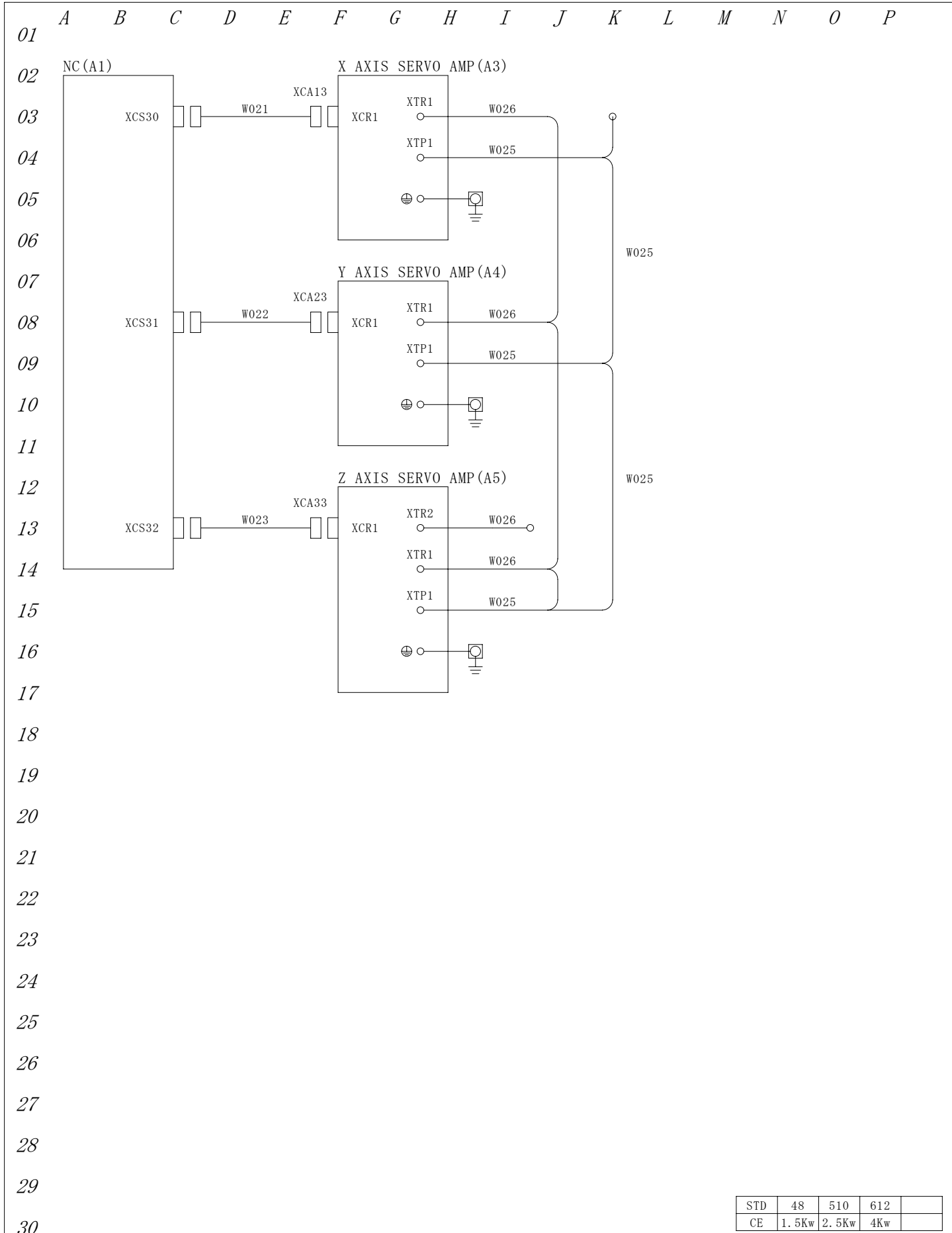

STD	48	510	612	
CE	1.5Kw	2.5Kw	4Kw	

△		 YAMAZAKI MAZAK CORPORATION	APR'D BY	CHK'D BY	DRWN BY	TITLE
△			99/11/30	99/11/30	99/11/30	CABINET
△			T. Inoue	M Okajima	M Okajima	CABLE CONNECTION (2)
△						DRWN NO.
△						676 001 51110, 0

This product is subject to all the applicable Japanese Foreign Exchange and Foreign Trade Law.
 本品は『外国為替及び外国貿易法』に該当しますので外国に輸出する場合には同法に基づく許可を必要とします。

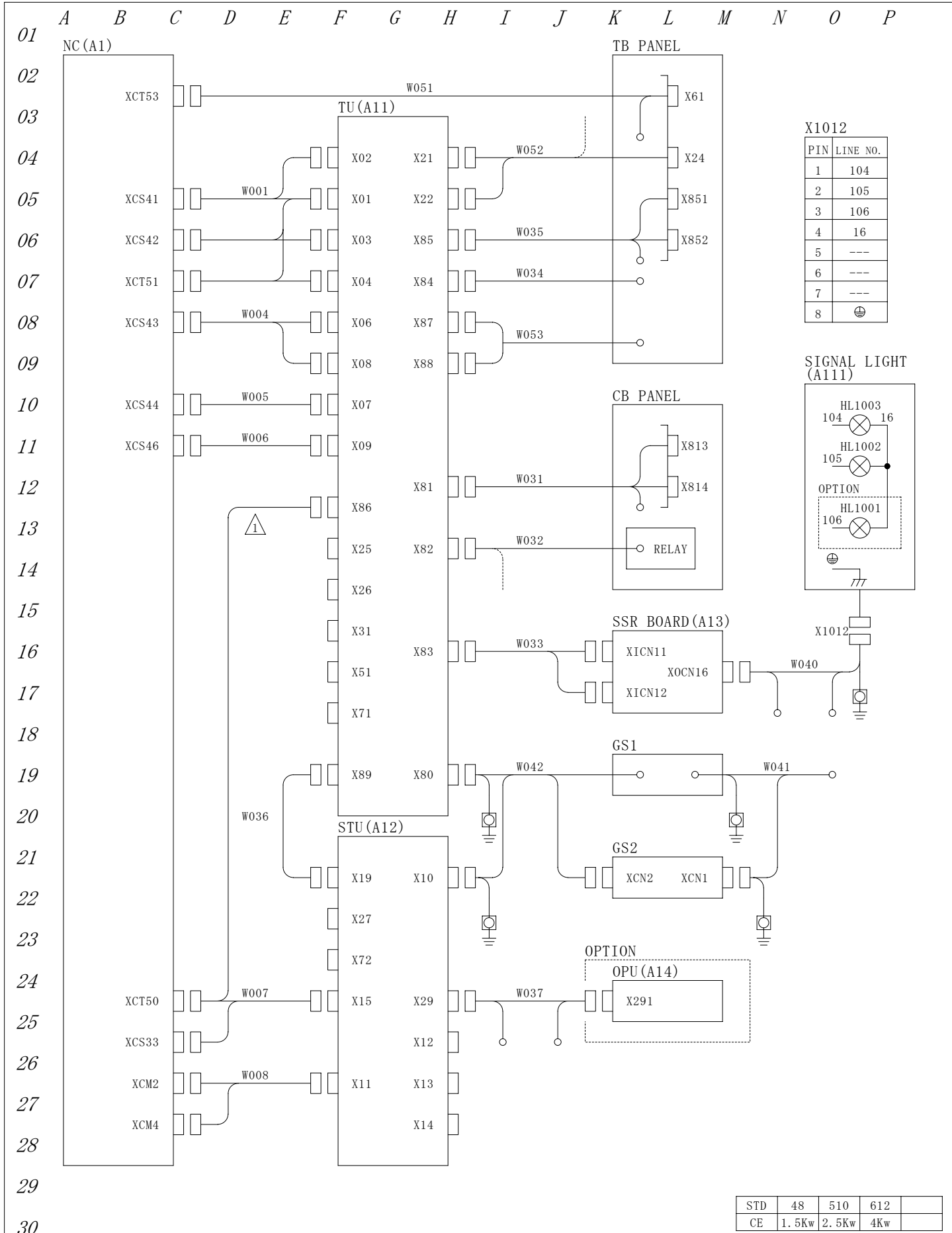

X1012

PIN	LINE NO.
1	104
2	105
3	106
4	16
5	---
6	---
7	---
8	⊕

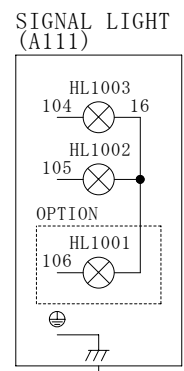

STD	48	510	612	
CE	1.5Kw	2.5Kw	4Kw	

△		 YAMAZAKI MAZAK CORPORATION	APR'D BY	CHK'D BY	DRWN BY	TITLE
△			99/11/30	99/11/30	99/11/30	CABINET CABLE CONNECTION (3)
△			T. Inoue	M Okajima	M Okajima	DRWN NO. 676 001 51121, 0
△			Edition Dec.19.'01 M.Okajima			

This product is subject to all the applicable Japanese Foreign Exchange and Foreign Trade Law.
 本品は『外国為替及び外国貿易法』に該当しますので外国に輸出する場合には同法に基づく許可を必要とします。

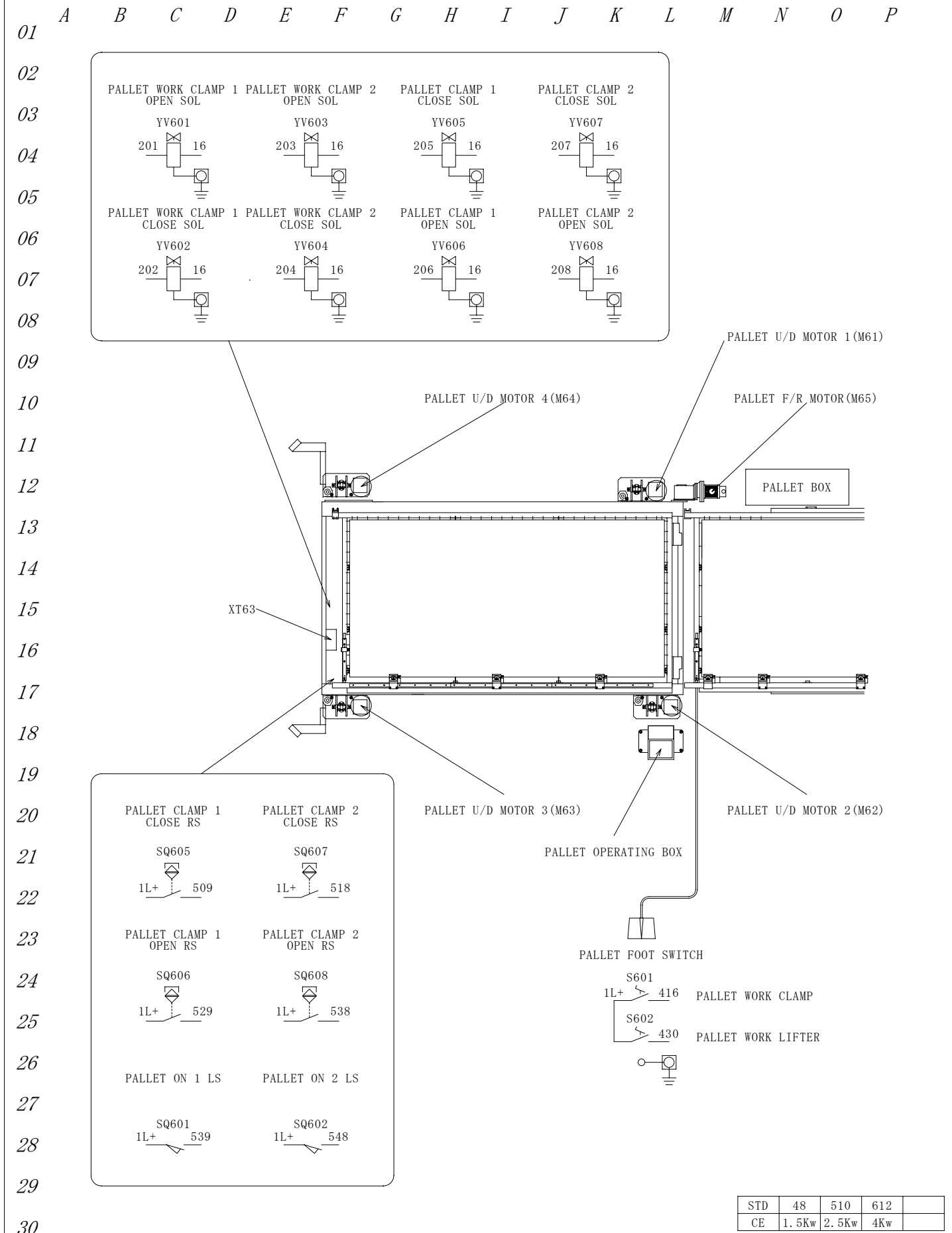

STD	48	510	612	
CE	1.5Kw	2.5Kw	4Kw	

△		 YAMAZAKI MAZAK CORPORATION	APR'D BY	CHK'D BY	DRWN BY	TITLE
△			99/11/30	99/11/30	99/11/30	PALLET CHANGER(OPTION) COMPORNENTS LAYOUT(1)
△			T. Inoue	M Okaji ma	M Okaji ma	DRWN NO. 676 001 36010, 0
△						
△						

This product is subject to all the applicable Japanese Foreign Exchange and Foreign Trade Law.
 本品は『外国為替及び外国貿易法』に該当しますので外国に輸出する場合には同法に基づく許可を必要とします。

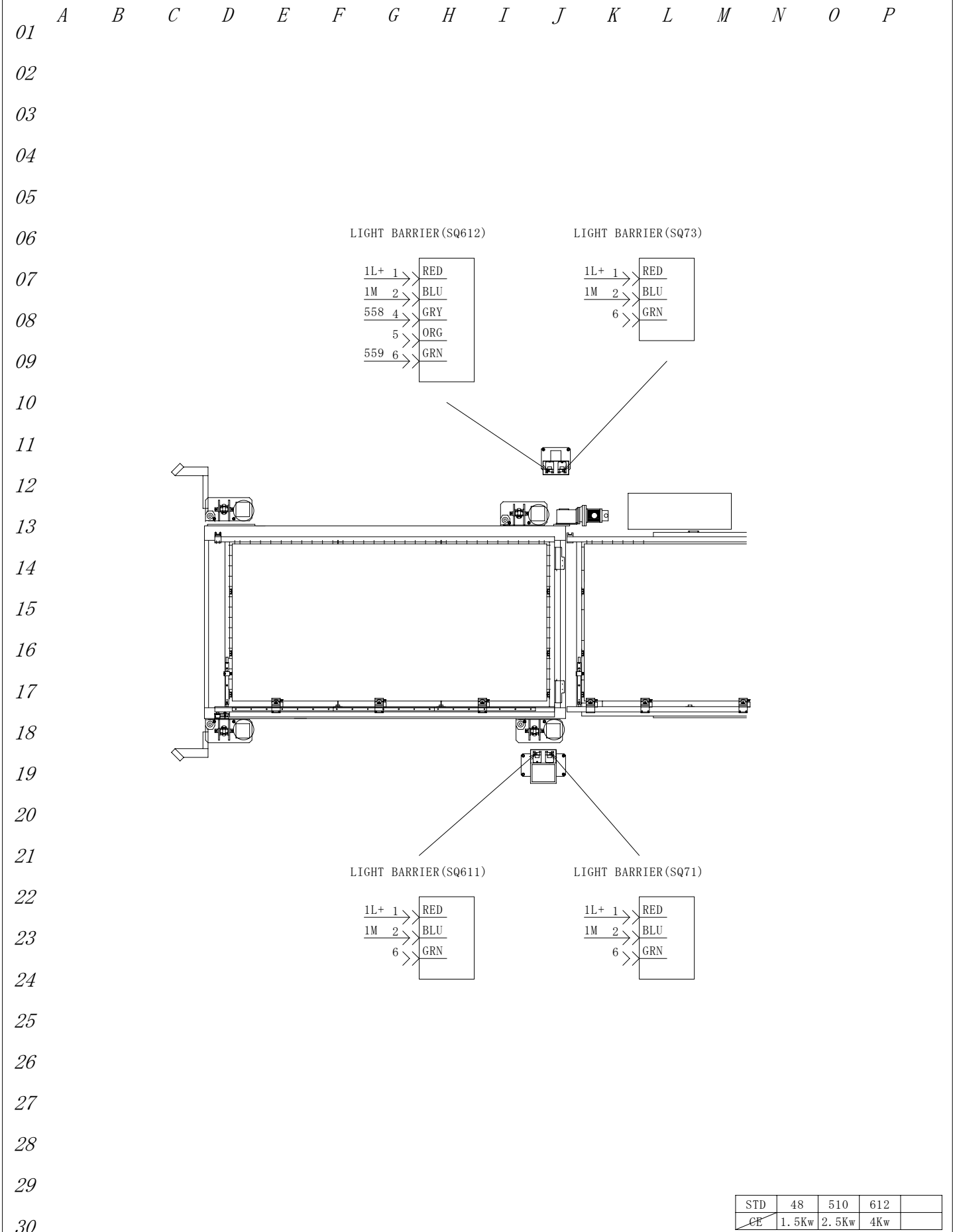

STD	48	510	612	
CE	1.5Kw	2.5Kw	4Kw	

 YAMAZAKI MAZAK CORPORATION	APR'D BY	CHK'D BY	DRWN BY	TITLE
	99/11/30	99/11/30	99/11/30	PALLET CHANGER(OPTION) COMPONENTS LAYOUT (2)
	T. Inoue	M Okajima	M Okajima	DRWN NO. 676 001 36020, 0

This product is subject to all the applicable Japanese Foreign Exchange and Foreign Trade Law.
 本品は『外国為替及び外国貿易法』に該当しますので外国に輸出する場合には同法に基づく許可を必要とします。

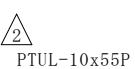
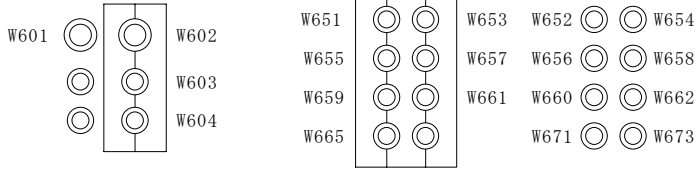
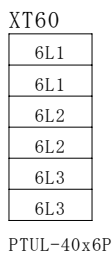
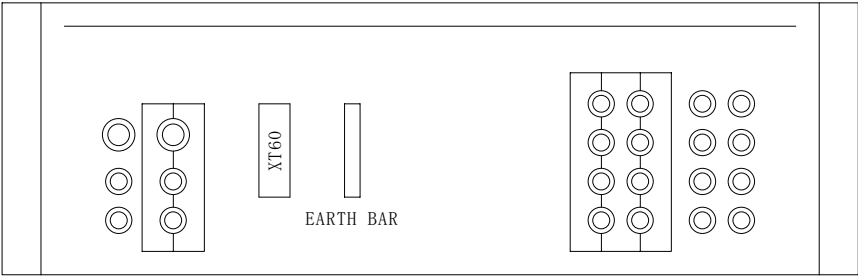
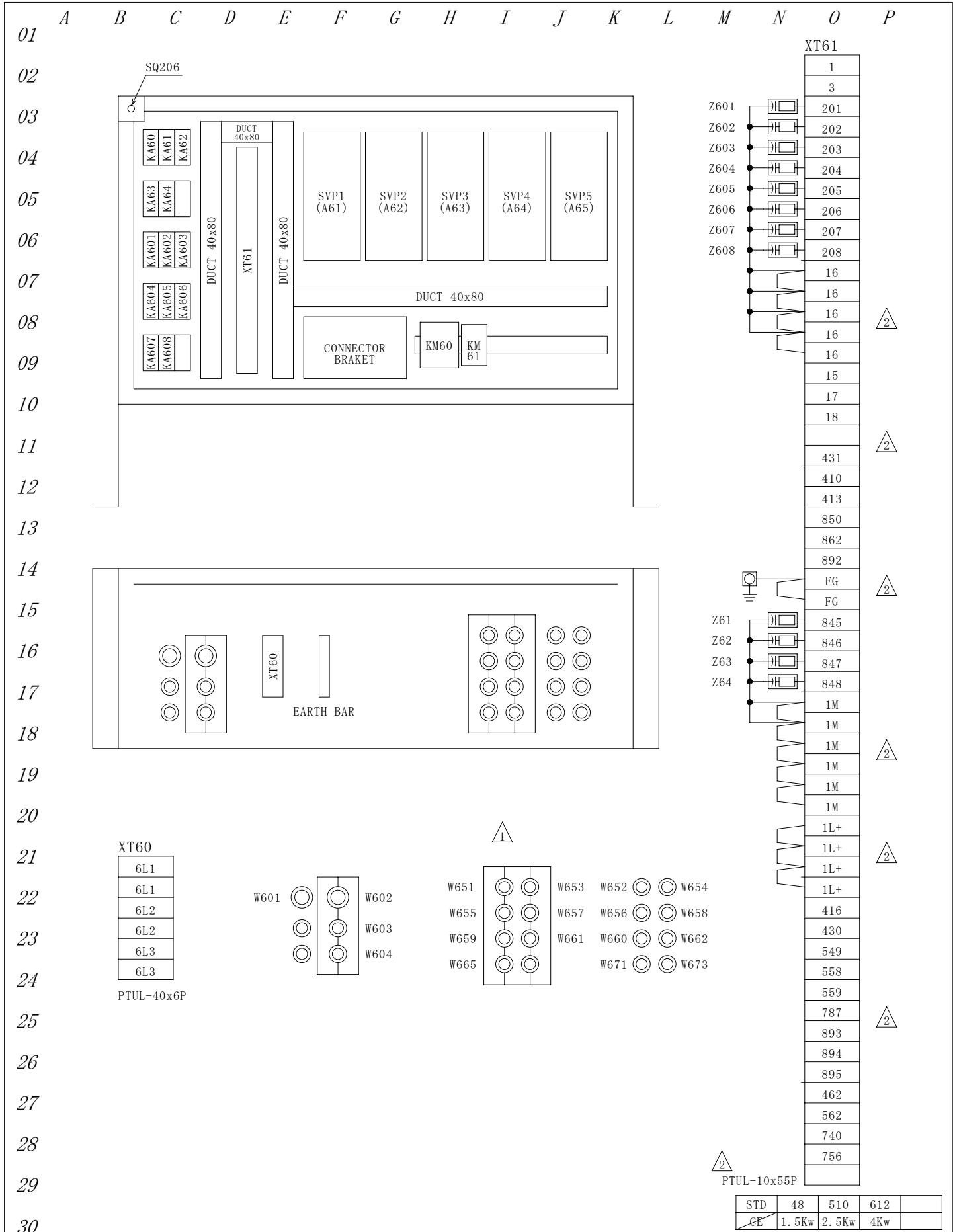

STD	48	510	612	
CE	1.5Kw	2.5Kw	4Kw	

△			APR'D BY	CHK'D BY	DRWN BY	TITLE
△			99/11/30	99/11/30	99/11/30	PALLET CHANGER (OPTION) BOX LAYOUT
△			T. Inoue	M Okajima	M Okajima	DRWN NO. 676 001 56012, 0
△	Edition Aug. 25.'00 M. Okajima		Mazak YAMAZAKI MAZAK CORPORATION			
△	Edition Apr. 07.'00 M. Okajima					

This product is subject to all the applicable Japanese Foreign Exchange and Foreign Trade Law.
 本品は『外国為替及び外国貿易法』に該当しますので外国に輸出する場合には同法に基づく許可を必要とします。

01 A B C D E F G H I J K L M N O P

02 CONNECTOR BRACKET

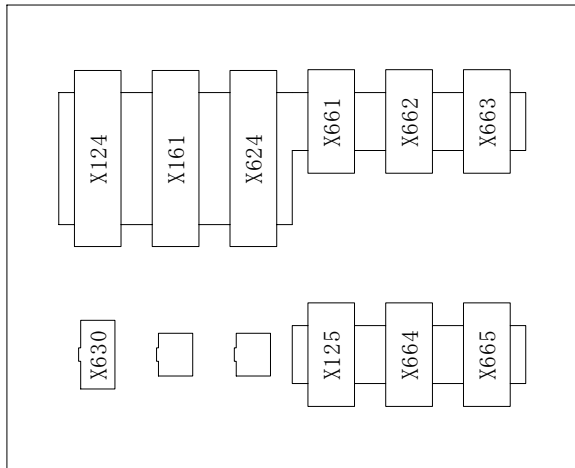

X125

PIN	LINE NO.
1	1L+
2	382
3	383
4	384
5	385
6	517
7	1L+
8	515
9	516
10	440
11	532
12	533
13	519
14	1M
15	528
16	747
17	780
18	776
19	777
20	1M

X124

PIN	LINE NO.
1	1L+
2	---
3	467
4	---
5	---
6	426
7	427
8	436
9	437
10	435
11	424
12	415
13	425
14	---
15	---
16	462
17	---
18	1L+
19	433
20	434
21	432
22	---
23	509
24	518
25	529
26	538
27	539
28	548
29	549
30	558
31	559
32	562
33	1M
34	---
35	740
36	756
37	416
38	430
39	410
40	411
41	412
42	413
43	431
44	9179
45	787
46	9181
47	9185
48	9186
49	---
50	1M

X161

PIN	LINE NO.
1	1L+
2	1L+
3	850
4	851
5	852
6	853
7	854
8	855
9	856
10	857
11	858
12	859
13	860
14	861
15	862
16	863
17	1L+
18	1L+
19	864
20	865
21	866
22	867
23	868
24	869
25	870
26	871
27	872
28	873
29	874
30	875
31	876
32	877
33	1M
34	1M
35	878
36	879
37	880
38	881
39	882
40	883
41	884
42	885
43	886
44	887
45	888
46	889
47	890
48	891
49	1M
50	1M

X624

PIN	LINE NO.
1	1L+
2	382
3	383
4	384
5	385
6	517
7	---
8	515
9	516
10	440
11	532
12	533
13	519
14	---
15	528
16	747
17	780
18	776
19	777
20	---
21	---
22	---
23	---
24	---
25	---
26	---
27	---
28	---
29	---
30	---
31	---
32	---
33	---
34	---
35	467
36	435
37	436
38	437
39	---
40	883
41	884
42	885
43	886
44	887
45	888
46	889
47	890
48	891
49	---
50	1M

03 X630

PIN	LINE NO.
1	1L+
2	509
3	518
4	529
5	538
6	539
7	548
8	1M

04 X661

PIN	LINE NO.
1	1L+
2	426
3	433
4	851
5	852
6	853
7	854
8	855
9	856
10	857
11	858
12	859
13	860
14	861
15	---
16	---
17	---
18	---
19	---
20	1M

05 X662

PIN	LINE NO.
1	1L+
2	411
3	424
4	851
5	852
6	853
7	854
8	855
9	856
10	857
11	858
12	859
13	860
14	861
15	---
16	---
17	---
18	---
19	---
20	1M

06 X663

PIN	LINE NO.
1	1L+
2	434
3	415
4	851
5	852
6	853
7	854
8	855
9	856
10	857
11	858
12	859
13	860
14	861
15	---
16	---
17	---
18	---
19	---
20	1M

07 X664

PIN	LINE NO.
1	1L+
2	412
3	427
4	851
5	852
6	853
7	854
8	855
9	856
10	857
11	858
12	859
13	860
14	861
15	---
16	---
17	---
18	---
19	---
20	1M

08 X665

PIN	LINE NO.
1	1L+
2	425
3	432
4	863
5	864
6	865
7	866
8	867
9	868
10	869
11	870
12	871
13	872
14	873
15	---
16	---
17	---
18	---
19	---
20	1M



STD	48	510	612	
CE	1.5Kw	2.5Kw	4Kw	

APR'D BY 99/11/30 T. Inoue	CHK'D BY 99/11/30 M Okajima	DRWN BY 99/11/30 M Okajima	TITLE PALLET CHANGER (OPTION) CONNECTOR BRACKET LAYOUT DRWN NO. 676 001 56021, 0
----------------------------------	-----------------------------------	----------------------------------	---



This product is subject to all the applicable Japanese Foreign Exchange and Foreign Trade Law.
 本品は『外国為替及び外国貿易法』に該当しますので外国に輸出する場合には同法に基づく許可を必要とします。

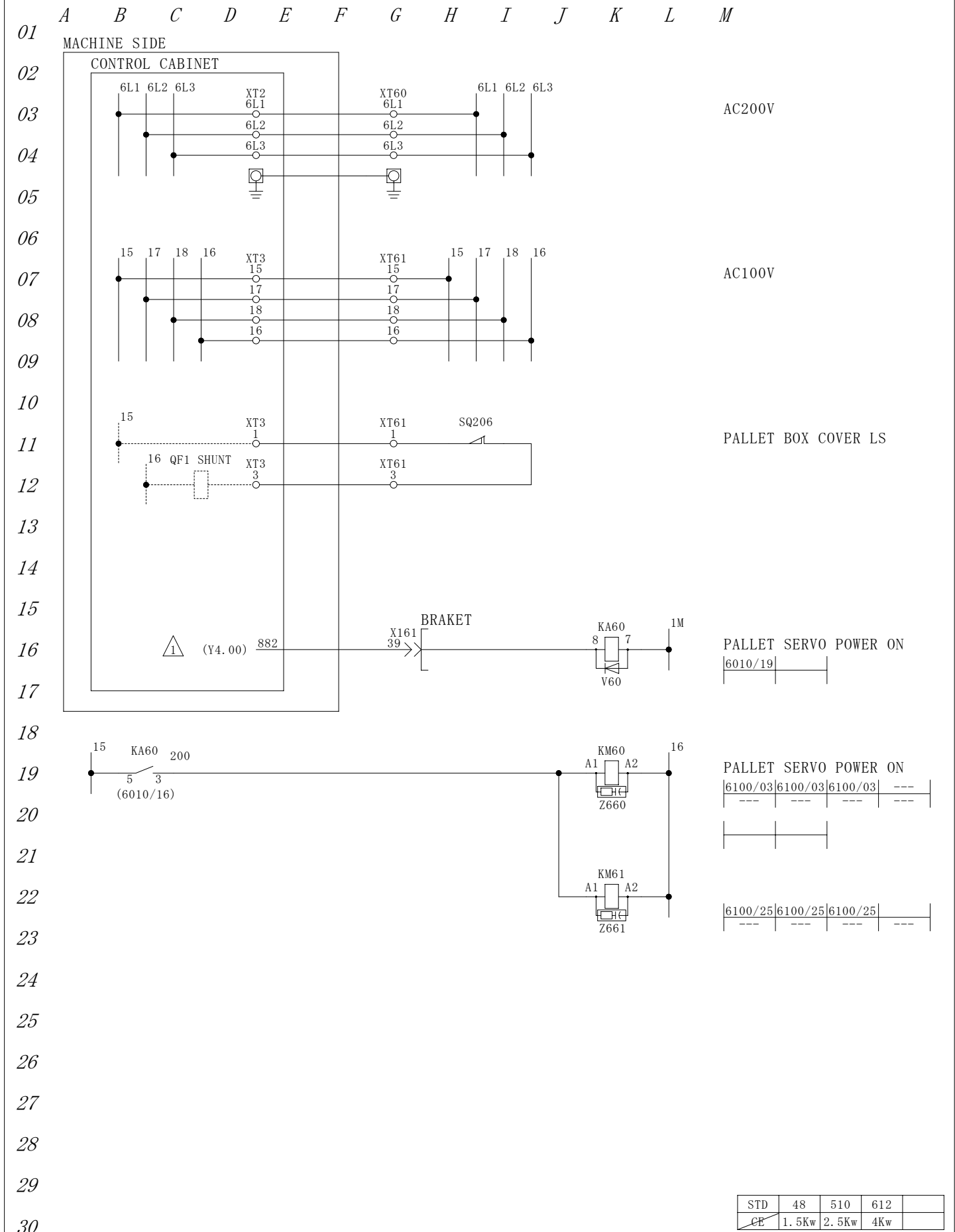

STD	48	510	612	
CE	1.5Kw	2.5Kw	4Kw	

	APR'D BY	CHK'D BY	DRWN BY	TITLE
	99/11/30	99/11/30	99/11/30	PALLET CHANGER (OPTION) POWER CIRCUIT
	T. Inoue	M Okajima	M Okajima	DRWN NO. 676 001 46011, 0

This product is subject to all the applicable Japanese Foreign Exchange and Foreign Trade Law.
 本品は『外国為替及び外国貿易法』に該当しますので外国に輸出する場合には同法に基づく許可を必要とします。

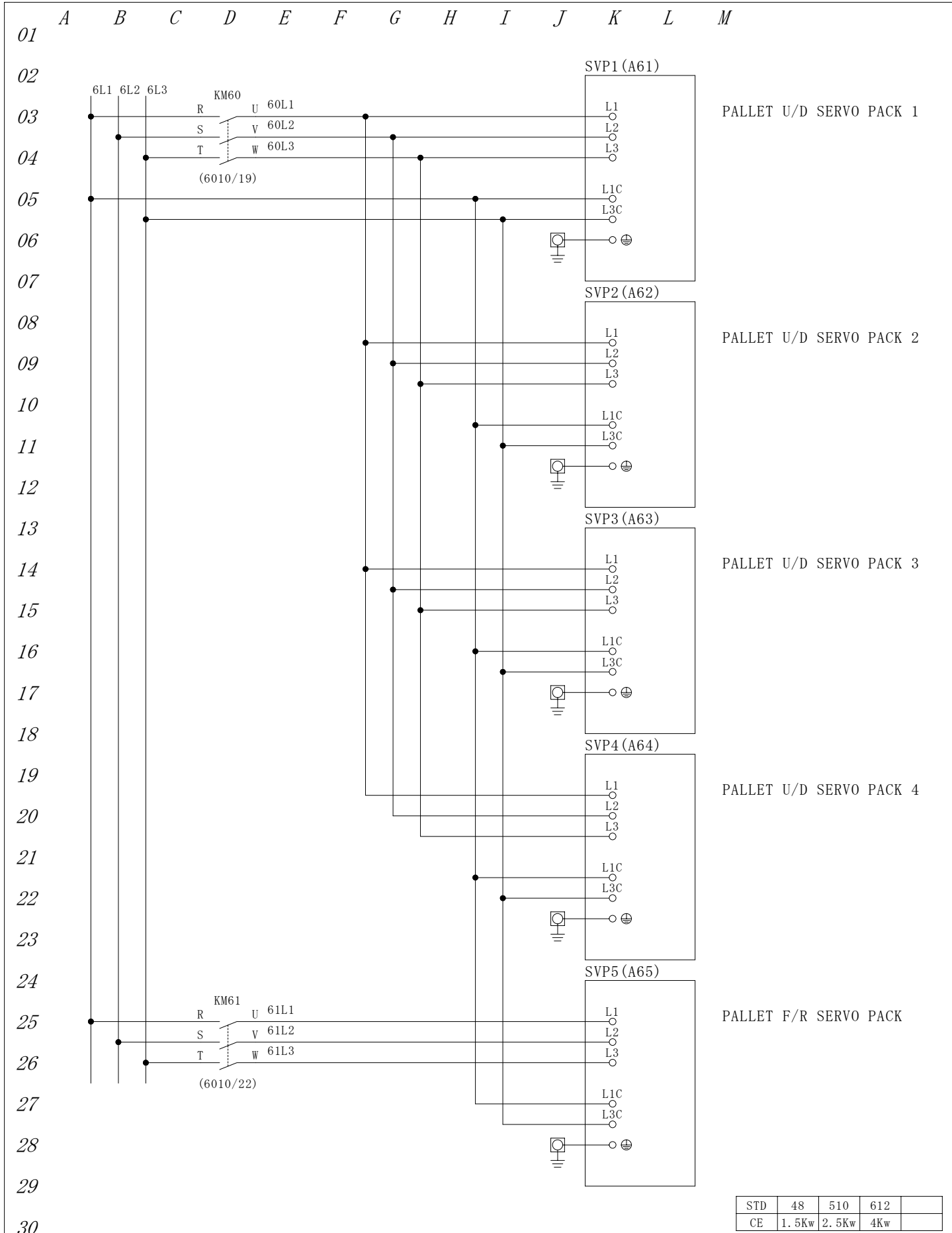

STD	48	510	612	
CE	1.5Kw	2.5Kw	4Kw	

△		 YAMAZAKI MAZAK CORPORATION	APR' D BY	CHK' D BY	DRWN BY	TITLE
△			99/11/30	99/11/30	99/11/30	PALLET CHANGER (OPTION) SERVO PACK
△			T. Inoue	M Okaji ma	M Okaji ma	
△						DRWN NO. 676 001 46100, 0
△						

This product is subject to all the applicable Japanese Foreign Exchange and Foreign Trade Law.
 本品は『外国為替及び外国貿易法』に該当しますので外国に輸出する場合には同法に基づく許可を必要とします。

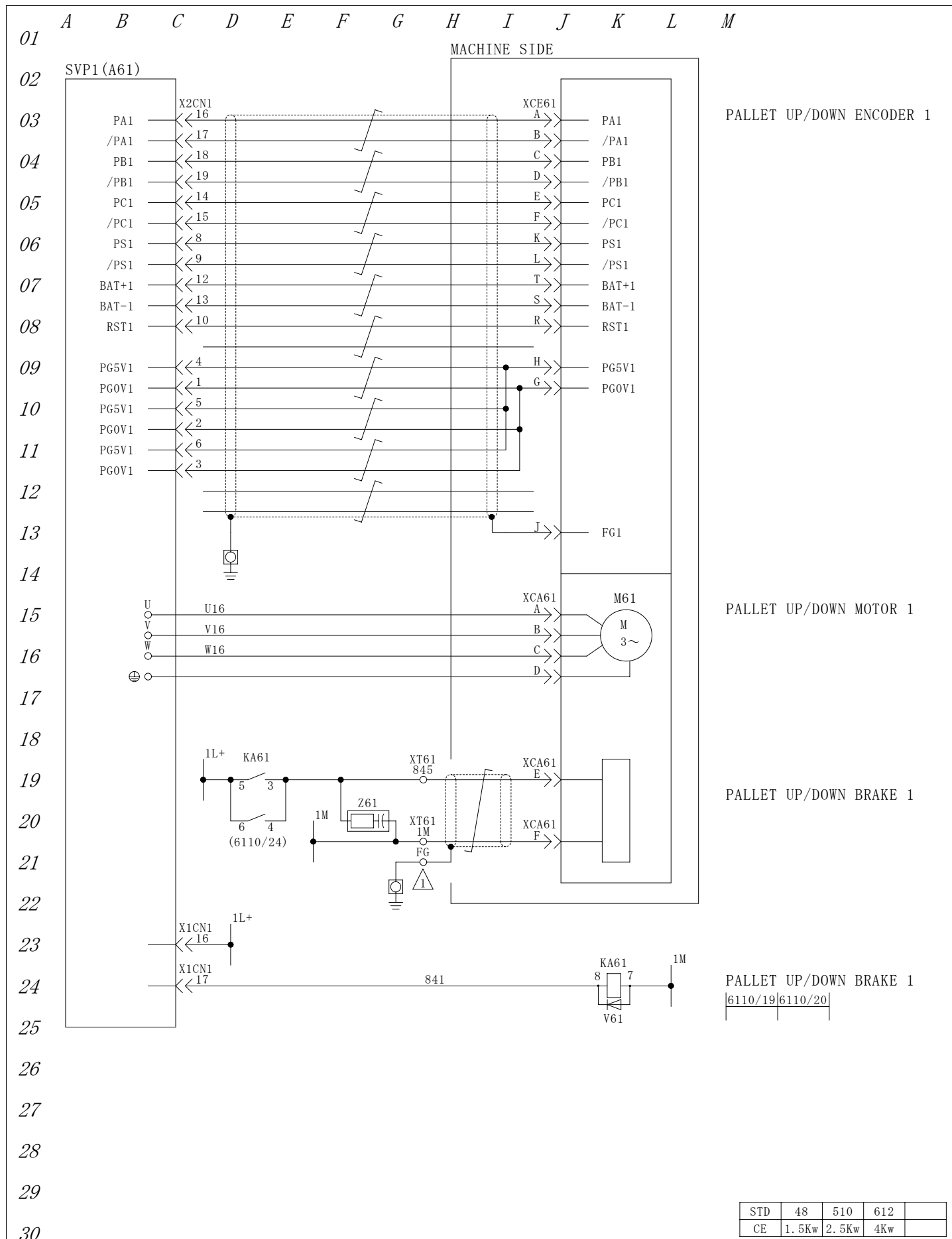

STD	48	510	612	
CE	1.5Kw	2.5Kw	4Kw	

△		 YAMAZAKI MAZAK CORPORATION	APR'D BY	CHK'D BY	DRWN BY	TITLE
△			99/11/30	99/11/30	99/11/30	PALLET CHANGER (OPTION) UP/DOWN MOTOR 1
△			T. Inoue	M Okaji ma	M Okaji ma	DRWN NO. 676 001 46111, 0
△	Edition Oct.05.'00 M.Okajima					

This product is subject to all the applicable Japanese Foreign Exchange and Foreign Trade Law.
 本品は『外国為替及び外国貿易法』に該当しますので外国に輸出する場合には同法に基づく許可を必要とします。

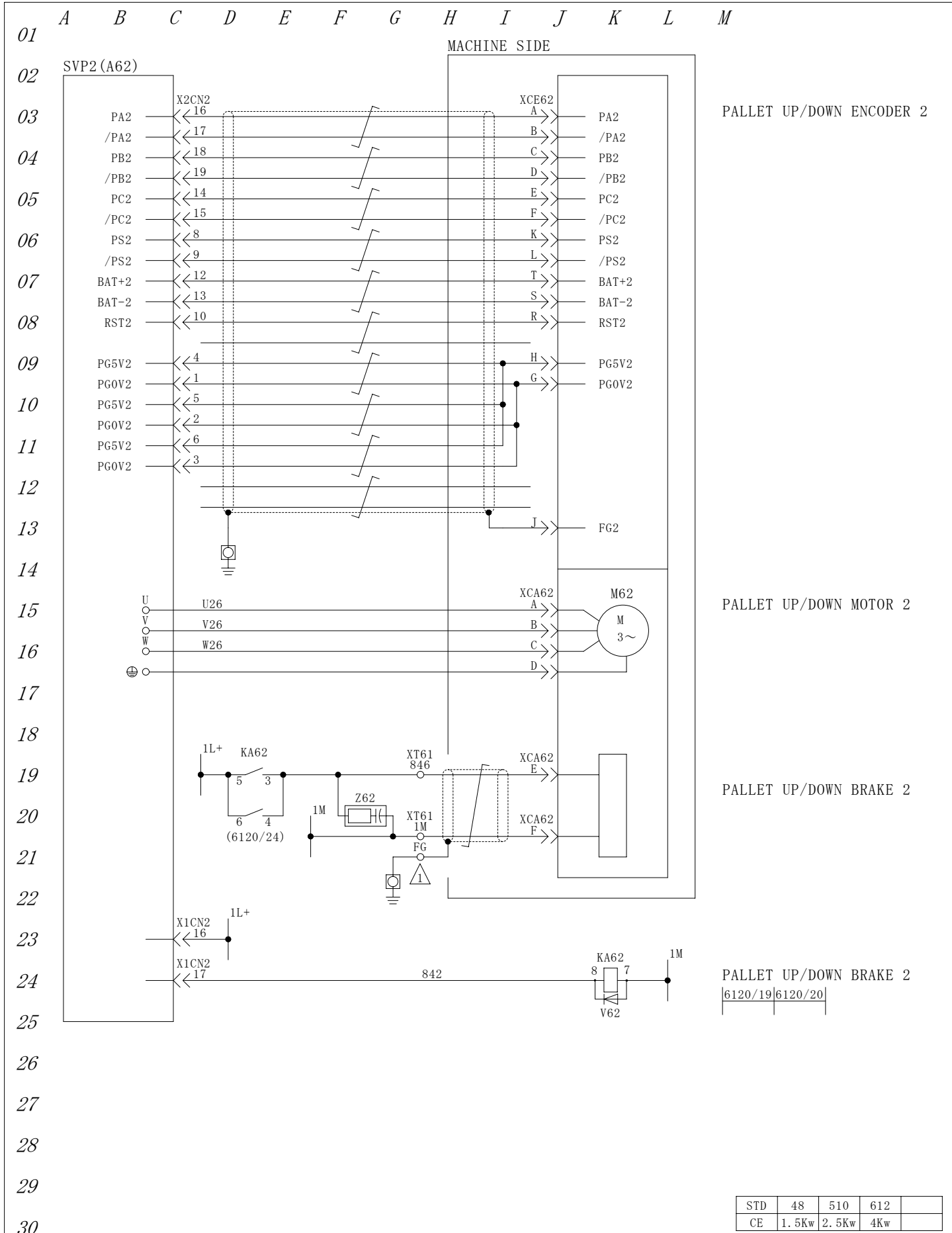

PALLET UP/DOWN ENCODER 2

PALLET UP/DOWN MOTOR 2

PALLET UP/DOWN BRAKE 2

PALLET UP/DOWN BRAKE 2
 6120/19 | 6120/20

STD	48	510	612	
CE	1.5Kw	2.5Kw	4Kw	

△		 YAMAZAKI MAZAK CORPORATION	APR' D BY	CHK' D BY	DRWN BY	TITLE
△			99/11/30	99/11/30	99/11/30	PALLET CHANGER (OPTION) UP/DOWN MOTOR 2
△			T. Inoue	M Okaji ma	M Okaji ma	DRWN NO. 676 001 46121, 0
△	Edition Oct.05.'00 M.Okajima					

This product is subject to all the applicable Japanese Foreign Exchange and Foreign Trade Law.
 本品は『外国為替及び外国貿易法』に該当しますので外国に輸出する場合には同法に基づく許可を必要とします。

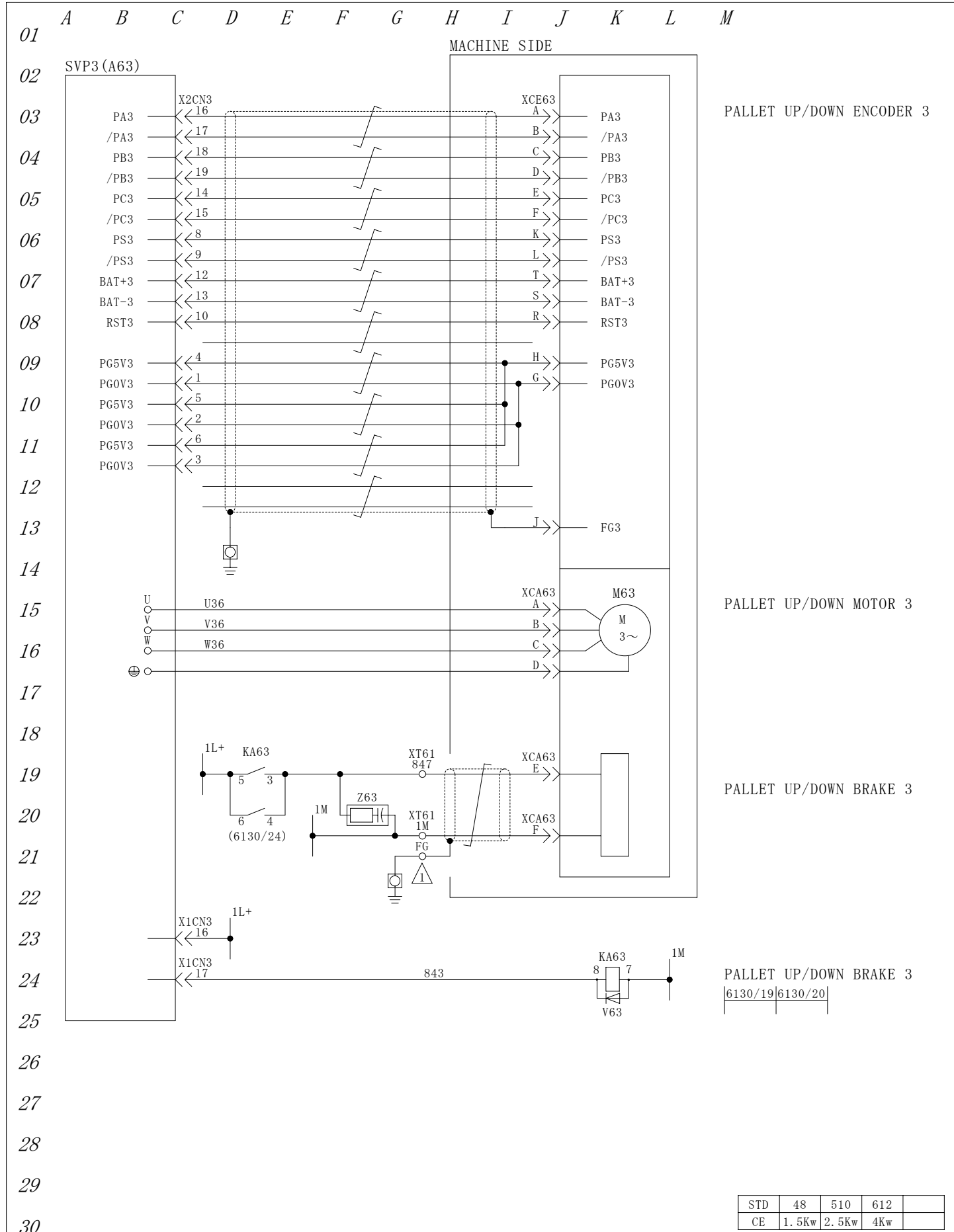

△		 YAMAZAKI MAZAK CORPORATION	APR' D BY	CHK' D BY	DRWN BY	TITLE
△			99/11/30	99/11/30	99/11/30	PALLET CHANGER (OPTION) UP/DOWN MOTOR 3
△			T. Inoue	M Okaji ma	M Okaji ma	DRWN NO. 676 001 46131, 0
△	Edition Oct.05.'00 M.Okajima					

This product is subject to all the applicable Japanese Foreign Exchange and Foreign Trade Law.
 本品は『外国為替及び外国貿易法』に該当しますので外国に輸出する場合には同法に基づく許可を必要とします。

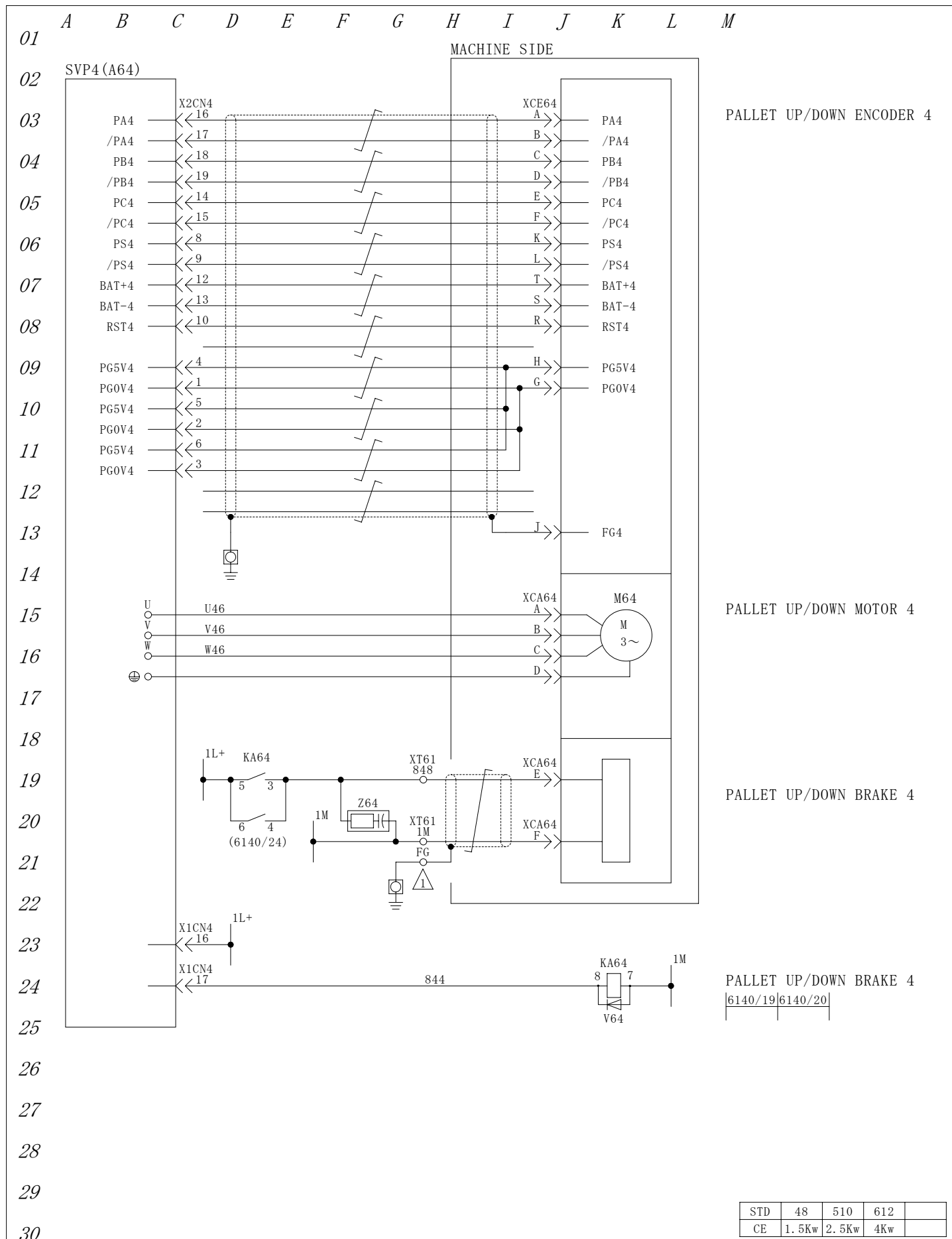

PALLET UP/DOWN ENCODER 4

PALLET UP/DOWN MOTOR 4

PALLET UP/DOWN BRAKE 4

PALLET UP/DOWN BRAKE 4
6140/19 | 6140/20

STD	48	510	612	
CE	1.5Kw	2.5Kw	4Kw	

△		 YAMAZAKI MAZAK CORPORATION	APR'D BY	CHK'D BY	DRWN BY	TITLE
△			99/11/30	99/11/30	99/11/30	PALLET CHANGER (OPTION) UP/DOWN MOTOR 4
△			T. Inoue	M Okaji ma	M Okaji ma	DRWN NO. 676 001 46141, 0
△	Edition Oct.05.'00 M.Okajima					

This product is subject to all the applicable Japanese Foreign Exchange and Foreign Trade Law.
 本品は『外国為替及び外国貿易法』に該当しますので外国に輸出する場合には同法に基づく許可を必要とします。

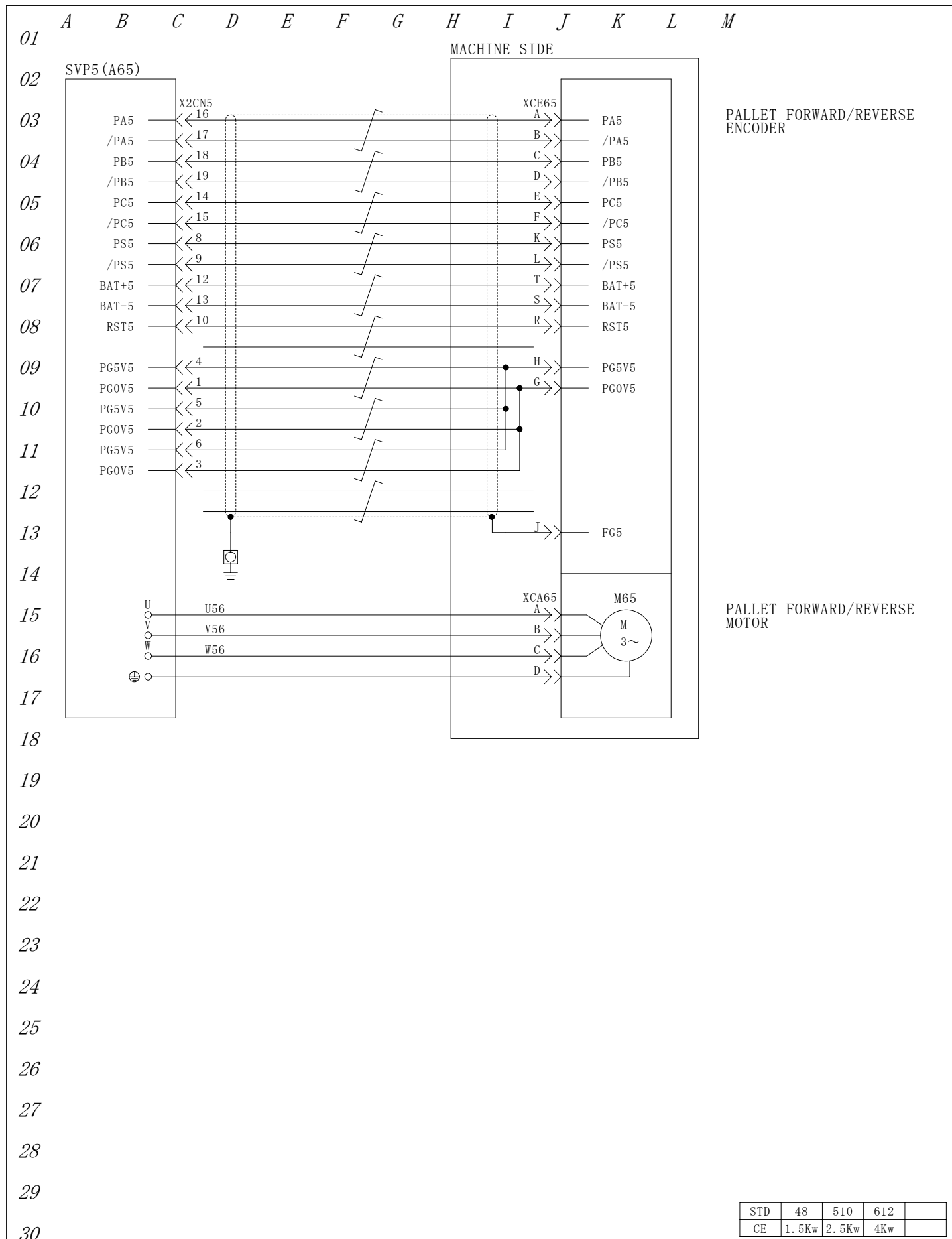

PALLET FORWARD/REVERSE ENCODER

PALLET FORWARD/REVERSE MOTOR

STD	48	510	612	
CE	1.5Kw	2.5Kw	4Kw	

△		 YAMAZAKI MAZAK CORPORATION	APR'D BY	CHK'D BY	DRWN BY	TITLE
△			99/11/30	99/11/30	99/11/30	PALLET CHANGER (OPTION) FWD/REV MOTOR
△			T. Inoue	M Okajima	M Okajima	DRWN NO. 676 001 46150, 0
△						
△						

This product is subject to all the applicable Japanese Foreign Exchange and Foreign Trade Law.
 本品は『外国為替及び外国貿易法』に該当しますので外国に輸出する場合には同法に基づく許可を必要とします。

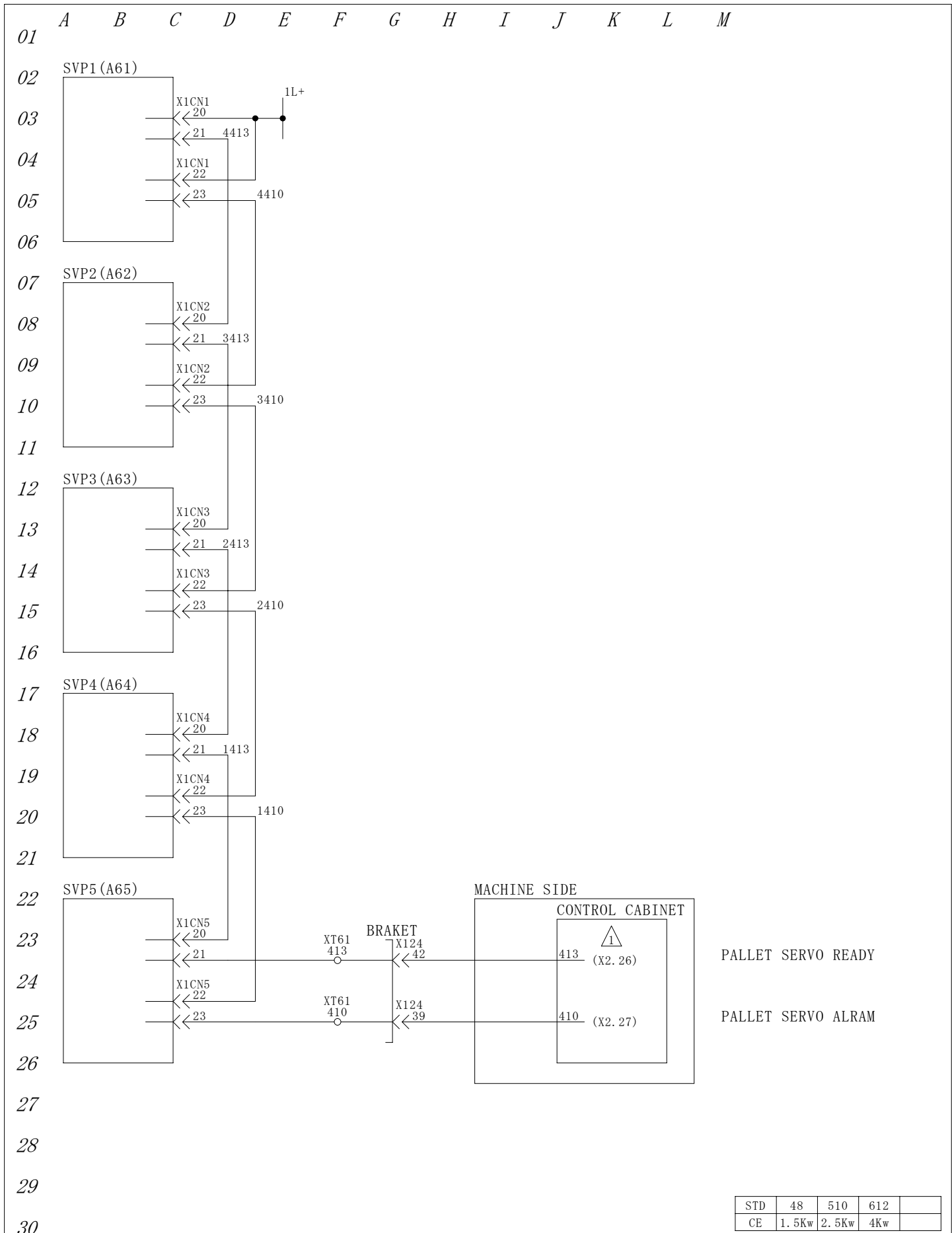

STD	48	510	612	
CE	1.5Kw	2.5Kw	4Kw	

△		 YAMAZAKI MAZAK CORPORATION	APR'D BY	CHK'D BY	DRWN BY	TITLE
△			99/11/30	99/11/30	99/11/30	PALLET CHANGER (OPTION) SERVO READY & ALARM
△			T. Inoue	M Okajima	M Okajima	DRWN NO. 676 001 46201, 0
△	Edition Oct.05.'00 M.Okajima					

This product is subject to all the applicable Japanese Foreign Exchange and Foreign Trade Law.
 本品は『外国為替及び外国貿易法』に該当しますので外国に輸出する場合には同法に基づく許可を必要とします。

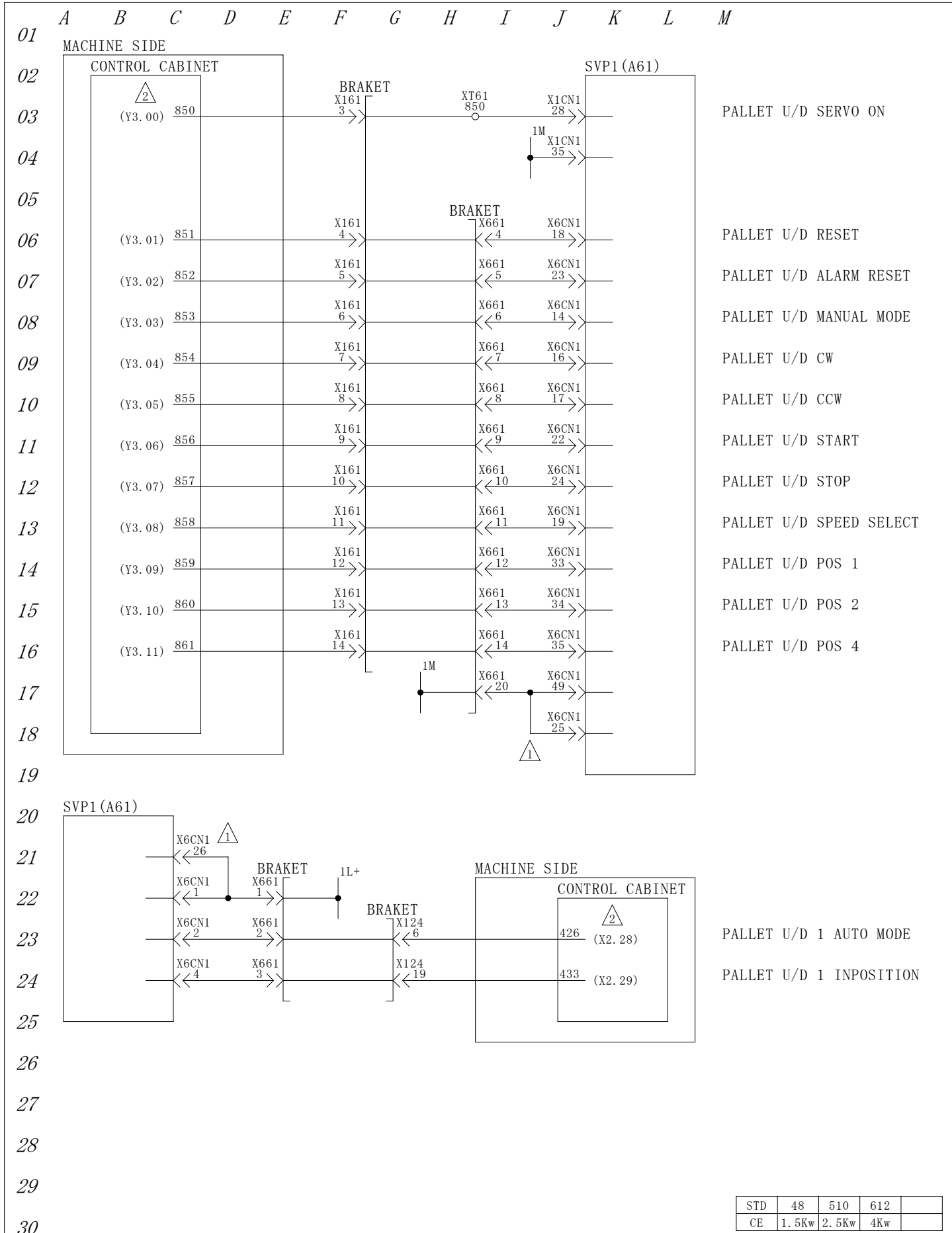

STD	48	510	612	
CE	1.5Kw	2.5Kw	4Kw	

△		 YAMAZAKI MAZAK CORPORATION	APR' D BY	CHK' D BY	DRWN BY	TITLE
△			99/11/30	99/11/30	99/11/30	PALLET CHANGER (OPTION) SERVO PACK 1
△			T. Inoue	M Okajima	M Okajima	DRWN NO. 676 001 46312.0
△	Edition Oct.05.'00 M.Okajima					
△	Edition May.19.'00 M.Okajima					

This product is subject to all the applicable Japanese Foreign Exchange and Foreign Trade Law.
 本品は『外国為替及び外国貿易法』に該当しますので外国に輸出する場合には同法に基づく許可を必要とします。

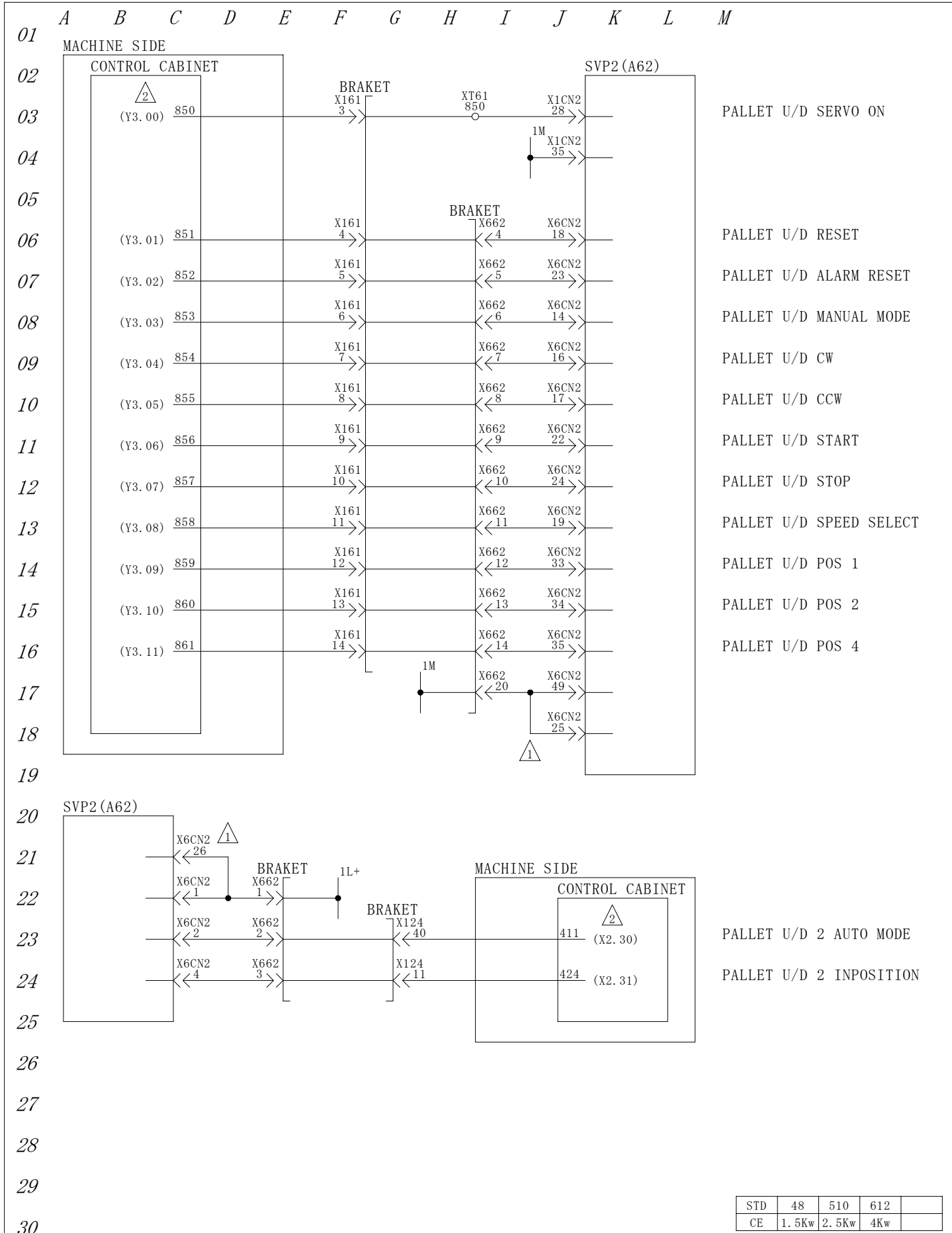

STD	48	510	612	
CE	1.5Kw	2.5Kw	4Kw	

△		 YAMAZAKI MAZAK CORPORATION	APR'D BY	CHK'D BY	DRWN BY	TITLE
△			99/11/30	99/11/30	99/11/30	PALLET CHANGER (OPTION) SERVO PACK 2
△			T. Inoue	M Okajima	M Okajima	DRWN NO. 676 001 46322, 0
△	Edition Oct.05.'00 M.Okajima					
△	Edition May.19.'00 M.Okajima					

This product is subject to all the applicable Japanese Foreign Exchange and Foreign Trade Law.
 本品は『外国為替及び外国貿易法』に該当しますので外国に輸出する場合には同法に基づく許可を必要とします。

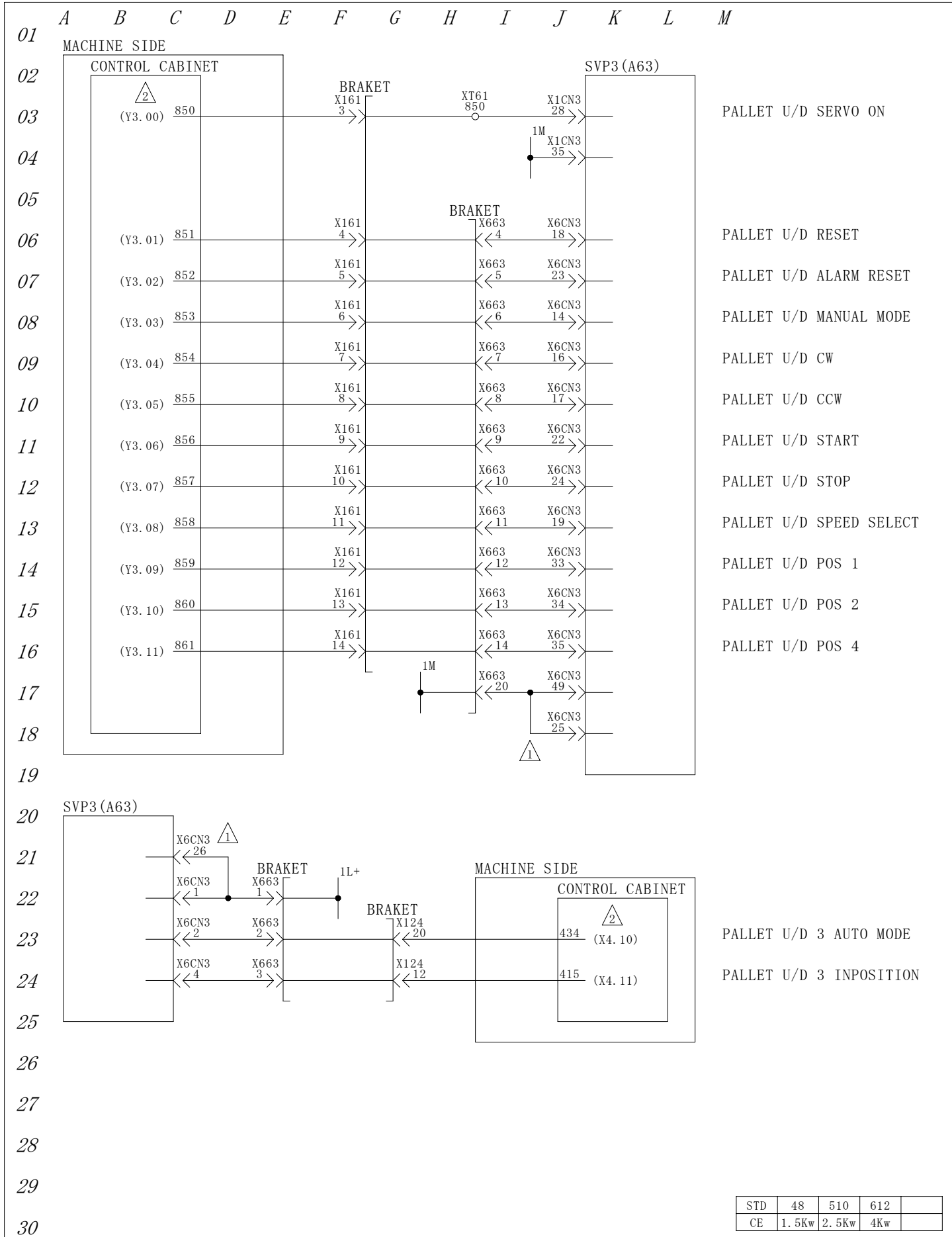

PALLET U/D SERVO ON

PALLET U/D RESET

PALLET U/D ALARM RESET

PALLET U/D MANUAL MODE

PALLET U/D CW

PALLET U/D CCW

PALLET U/D START

PALLET U/D STOP

PALLET U/D SPEED SELECT

PALLET U/D POS 1

PALLET U/D POS 2

PALLET U/D POS 4

PALLET U/D 3 AUTO MODE

PALLET U/D 3 INPOSITION

STD	48	510	612	
CE	1.5Kw	2.5Kw	4Kw	

△		 YAMAZAKI MAZAK CORPORATION	APR'D BY	CHK'D BY	DRWN BY	TITLE
△			99/11/30	99/11/30	99/11/30	PALLET CHANGER (OPTION) SERVO PACK 3
△			T. Inoue	M Okajima	M Okajima	DRWN NO. 676 001 46332, 0
△	Edition Oct.05.'00 M.Okajima					
△	Edition May.19.'00 M.Okajima					

This product is subject to all the applicable Japanese Foreign Exchange and Foreign Trade Law.
 本品は『外国為替及び外国貿易法』に該当しますので外国に輸出する場合には同法に基づく許可を必要とします。

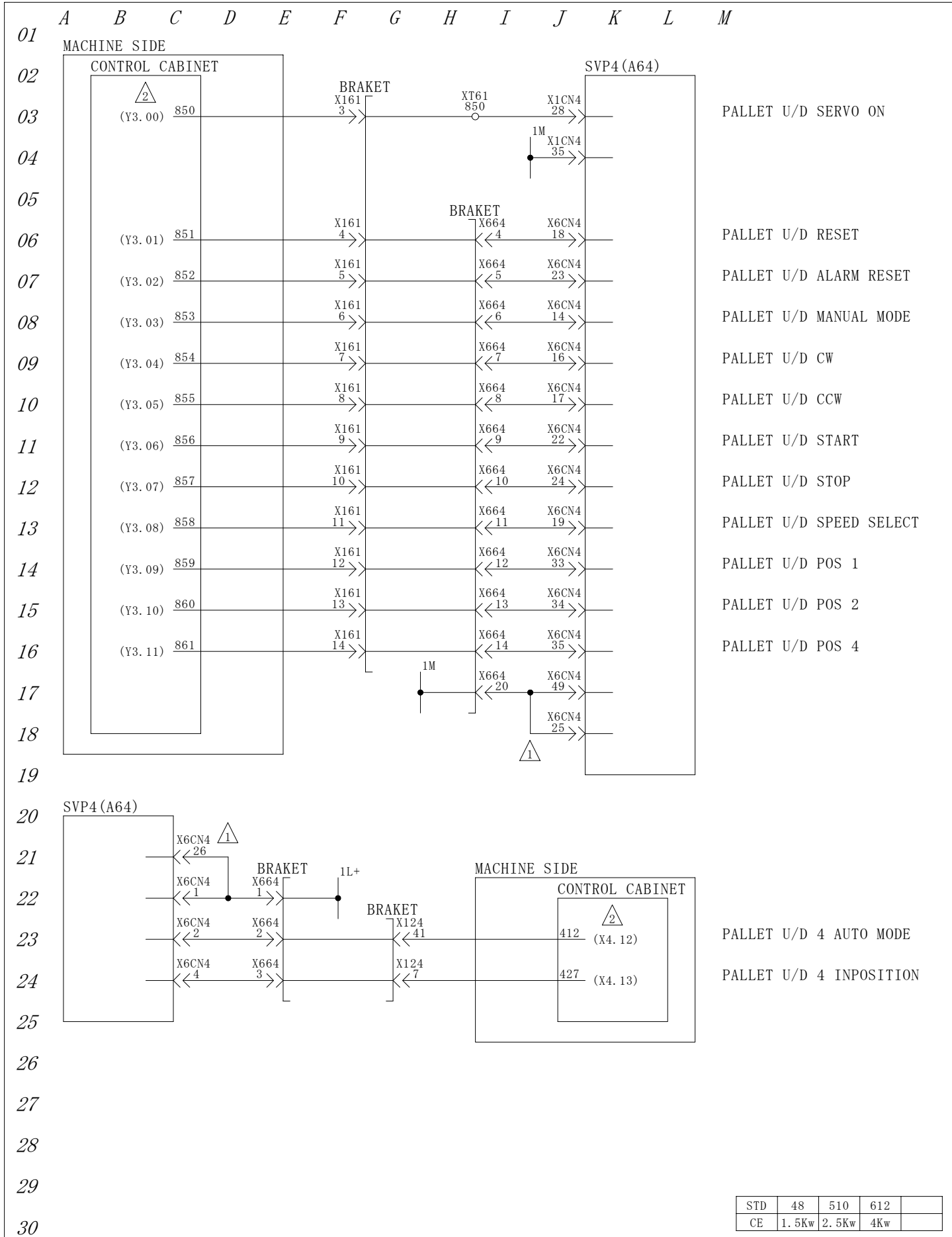

STD	48	510	612	
CE	1.5Kw	2.5Kw	4Kw	

△		 YAMAZAKI MAZAK CORPORATION	APR'D BY	CHK'D BY	DRWN BY	TITLE
△			99/11/30	99/11/30	99/11/30	PALLET CHANGER (OPTION) SERVO PACK 4
△			T. Inoue	M Okajima	M Okajima	DRWN NO. 676 001 46342.0
△	Edition Oct.05.'00 M.Okajima					
△	Edition May.19.'00 M.Okajima					

This product is subject to all the applicable Japanese Foreign Exchange and Foreign Trade Law.
 本品は『外国為替及び外国貿易法』に該当しますので外国に輸出する場合には同法に基づく許可を必要とします。

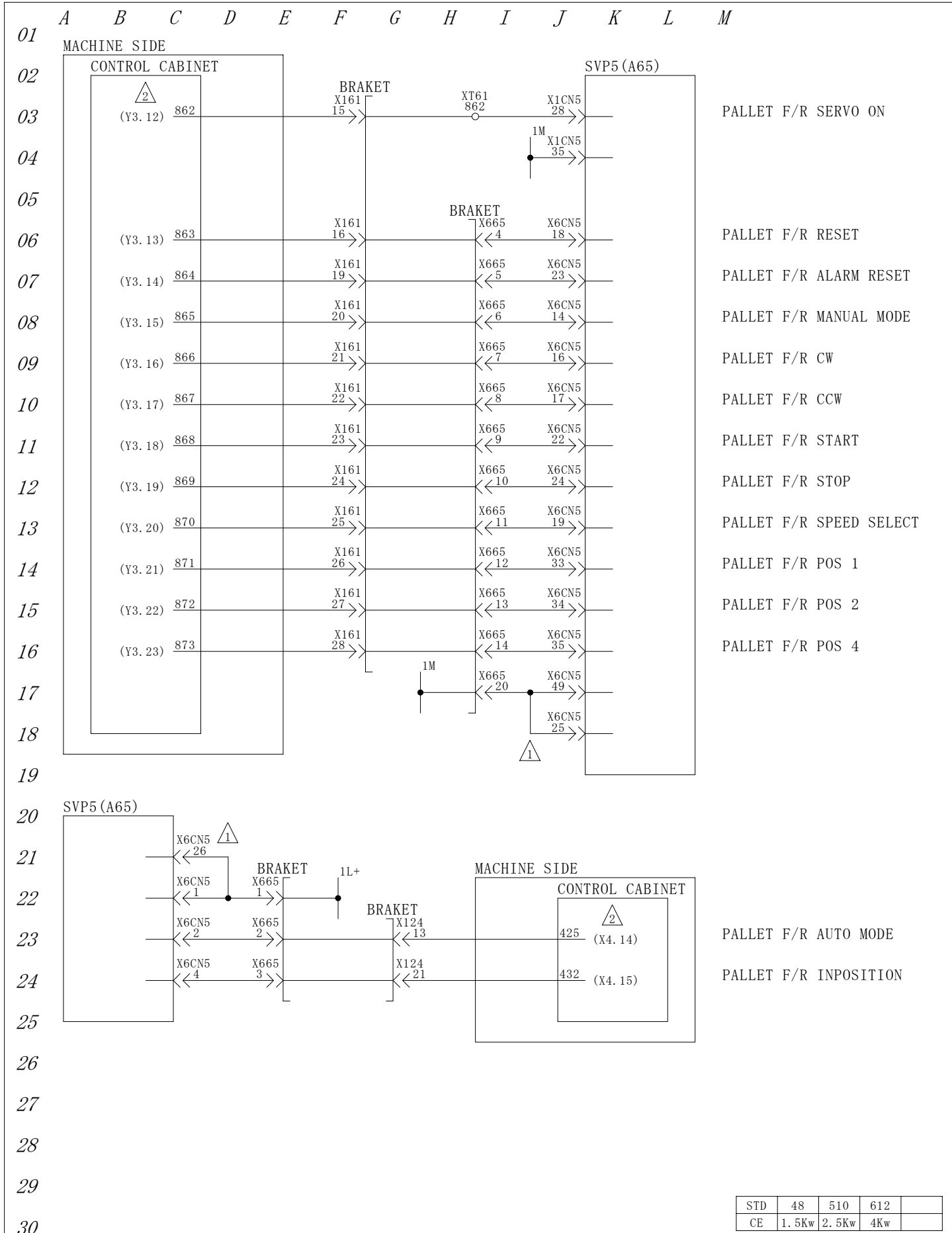

△		 YAMAZAKI MAZAK CORPORATION	APR'D BY	CHK'D BY	DRWN BY	TITLE
△			99/11/30	99/11/30	99/11/30	PALLET CHANGER (OPTION) SERVO PACK 5
△			T. Inoue	M Okajima	M Okajima	DRWN NO. 676 001 46352, 0
△	Edition Oct.05.'00 M.Okajima					
△	Edition May.19.'00 M.Okajima					

This product is subject to all the applicable Japanese Foreign Exchange and Foreign Trade Law.
 本品は『外国為替及び外国貿易法』に該当しますので外国に輸出する場合には同法に基づく許可を必要とします。

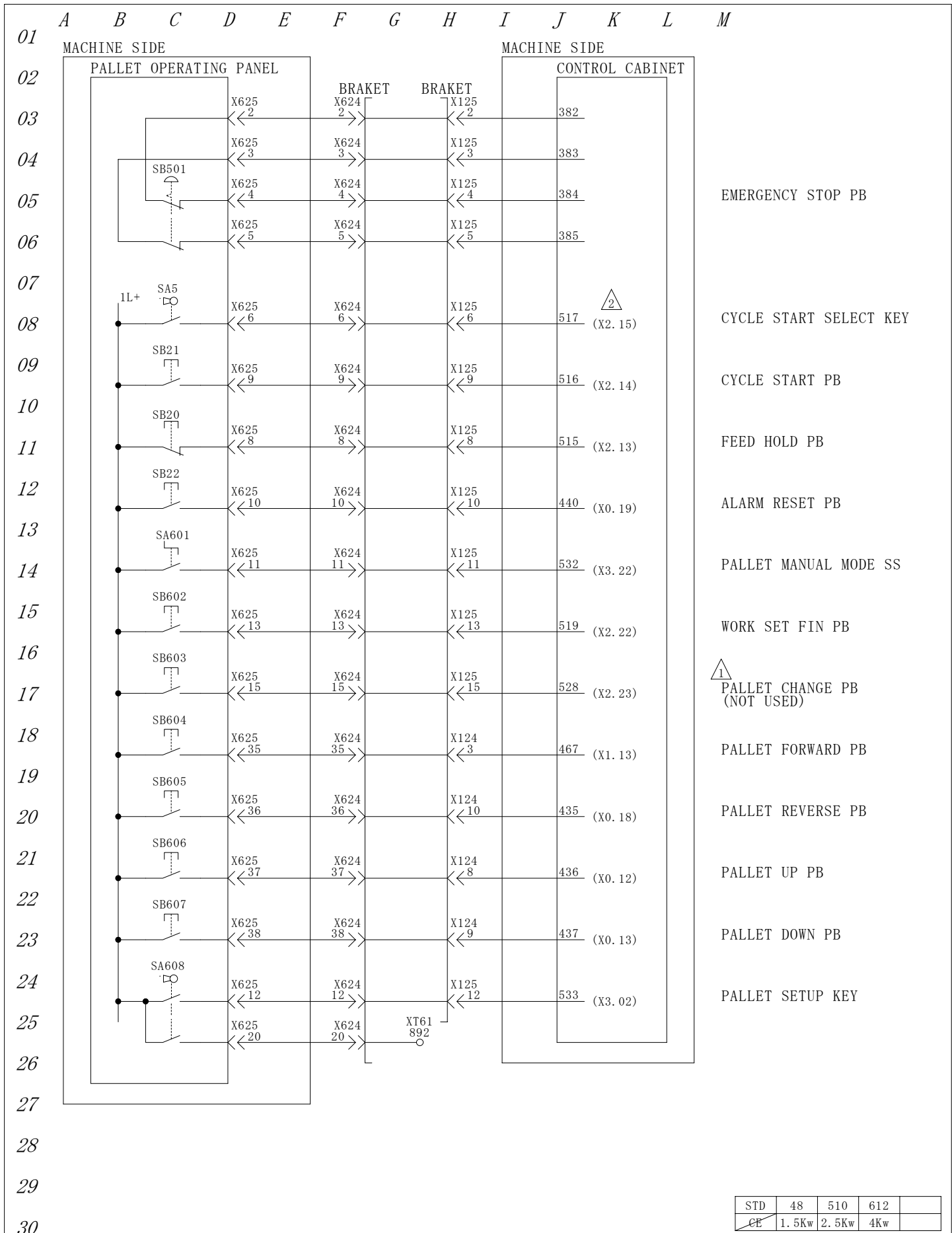

STD	48	510	612	
CE	1.5Kw	2.5Kw	4Kw	

△		 YAMAZAKI MAZAK CORPORATION	APR'D BY	CHK'D BY	DRWN BY	TITLE
△			99/11/30	99/11/30	99/11/30	PALLET CHANGER (OPTION) OPERATING PANEL (1)
△			T. Inoue	M Okajima	M Okajima	DRWN NO. 676 001 46402, 0
△	Edition Oct.05.'00 M.Okajima					
△	Edition Jul.01.'00 M.Okajima					

This product is subject to all the applicable Japanese Foreign Exchange and Foreign Trade Law.
 本品は『外国為替及び外国貿易法』に該当しますので外国に輸出する場合には同法に基づく許可を必要とします。

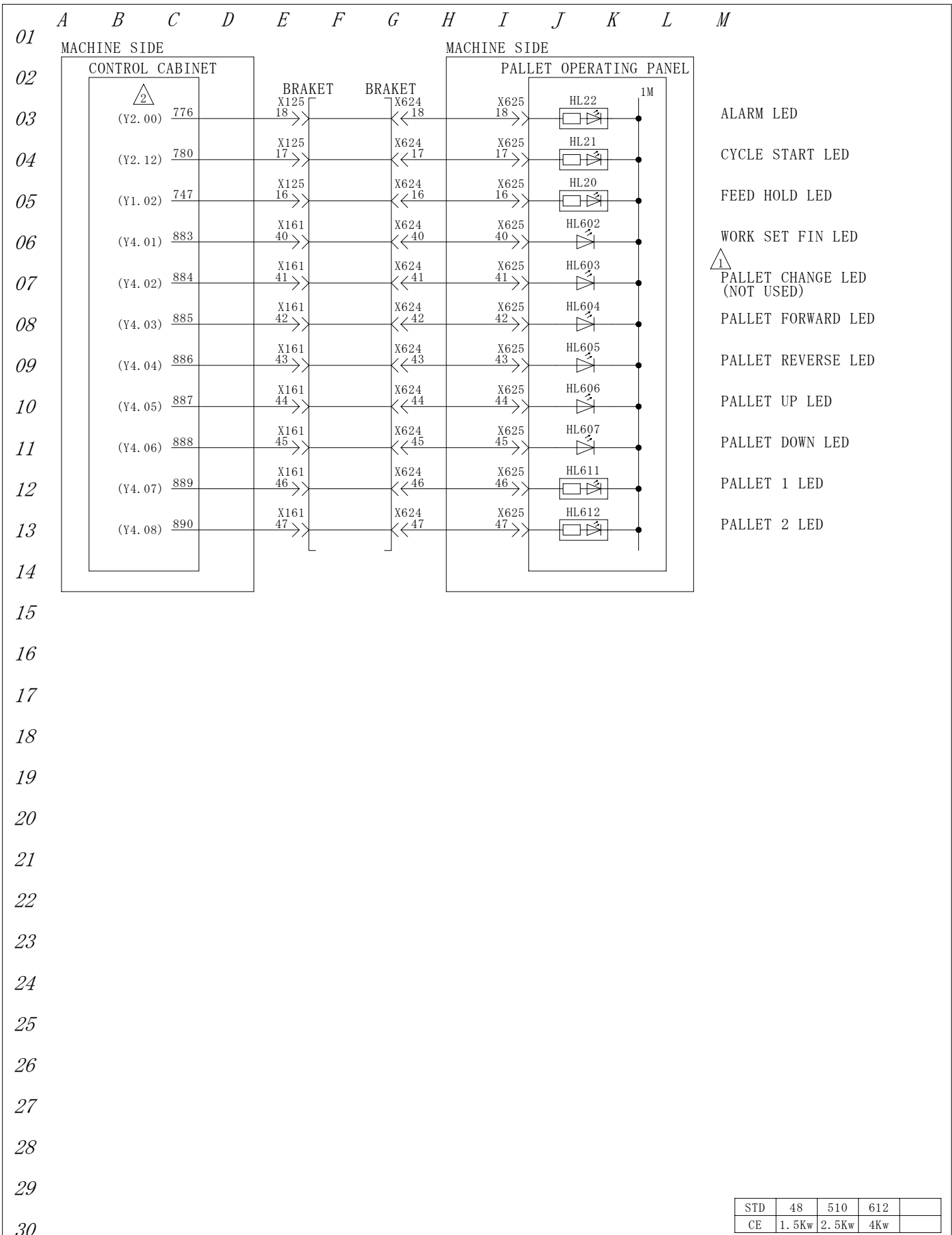



STD	48	510	612	
CE	1.5Kw	2.5Kw	4Kw	

APR'D BY	CHK'D BY	DRWN BY	TITLE
99/11/30	99/11/30	99/11/30	PALLET CHANGER (OPTION) OPERATING PANEL (2)
T. Inoue	M Okajima	M Okajima	DRWN NO. 676 001 46412, 0

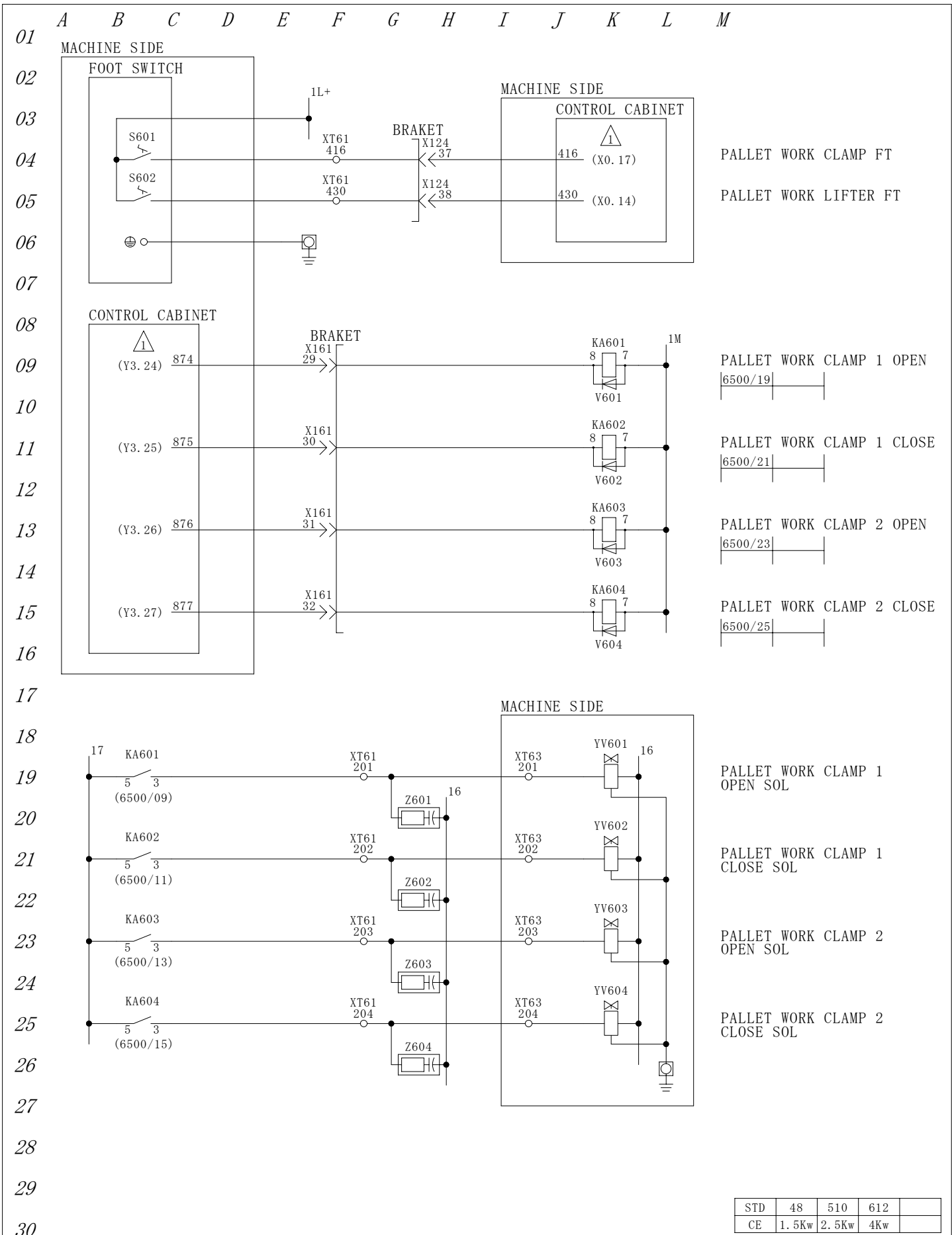

This product is subject to all the applicable Japanese Foreign Exchange and Foreign Trade Law.
 本品は『外国為替及び外国貿易法』に該当しますので外国に輸出する場合には同法に基づく許可を必要とします。



△		 YAMAZAKI MAZAK CORPORATION	APR' D BY	CHK' D BY	DRWN BY	TITLE
△			99/11/30	99/11/30	99/11/30	PALLET CHANGER (OPTION) WORK CLAMP
△			T. Inoue	M Okajima	M Okajima	DRWN NO. 676 001 46501, 0
△	Edition Oct.05.'00 M.Okajima					

This product is subject to all the applicable Japanese Foreign Exchange and Foreign Trade Law.
 本品は『外国為替及び外国貿易法』に該当しますので外国に輸出する場合には同法に基づく許可を必要とします。

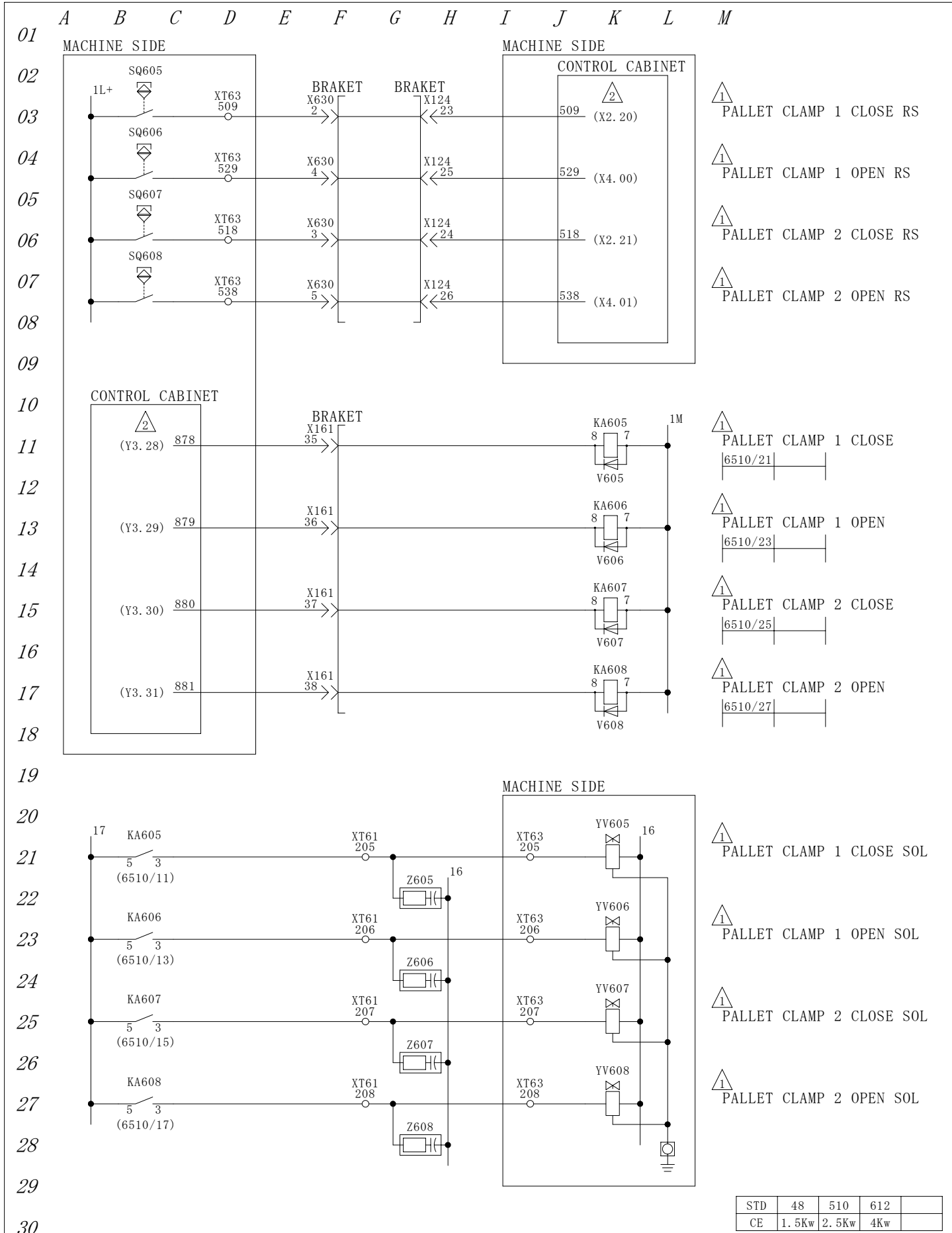

- △1 PALLET CLAMP 1 CLOSE RS
- △1 PALLET CLAMP 1 OPEN RS
- △1 PALLET CLAMP 2 CLOSE RS
- △1 PALLET CLAMP 2 OPEN RS

- △1 PALLET CLAMP 1 CLOSE
|6510/21|
- △1 PALLET CLAMP 1 OPEN
|6510/23|
- △1 PALLET CLAMP 2 CLOSE
|6510/25|
- △1 PALLET CLAMP 2 OPEN
|6510/27|

- △1 PALLET CLAMP 1 CLOSE SOL
- △1 PALLET CLAMP 1 OPEN SOL
- △1 PALLET CLAMP 2 CLOSE SOL
- △1 PALLET CLAMP 2 OPEN SOL

STD	48	510	612	
CE	1.5Kw	2.5Kw	4Kw	

△1		 YAMAZAKI MAZAK CORPORATION	APR' D BY	CHK' D BY	DRWN BY	TITLE
△1			99/11/30	99/11/30	99/11/30	PALLET CHANGER (OPTION) PALLET CLAMP
△1			T. Inoue	M Okajima	M Okajima	DRWN NO. 676 001 46512.0
△1			Edition Oct.05.'00 M.Okajima			
△1		Edition May.19.'00 M.Okajima				

This product is subject to all the applicable Japanese Foreign Exchange and Foreign Trade Law.
 本品は『外国為替及び外国貿易法』に該当しますので外国に輸出する場合には同法に基づく許可を必要とします。

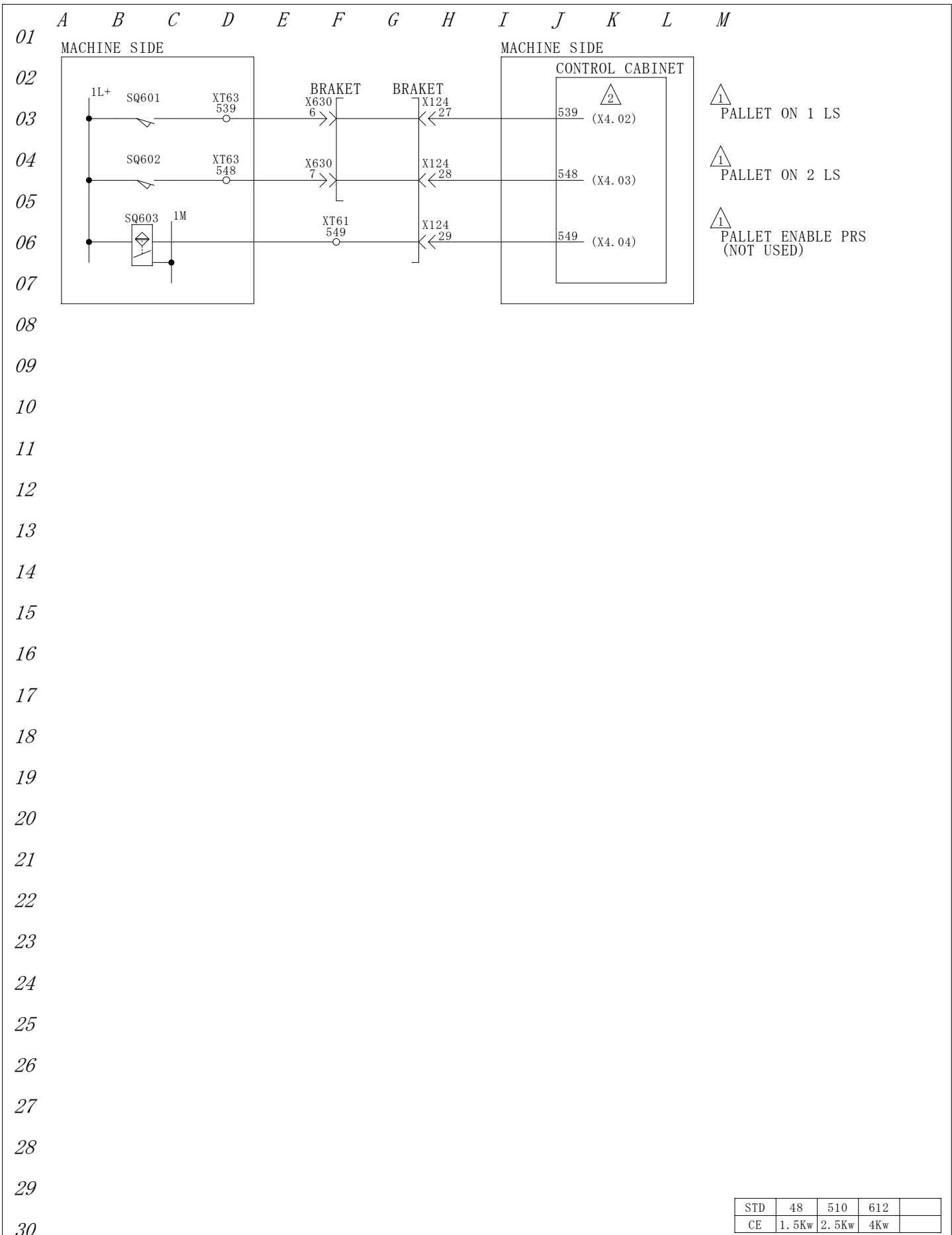

STD	48	510	612	
CE	1.5Kw	2.5Kw	4Kw	

△		 YAMAZAKI MAZAK CORPORATION	APR'D BY	CHK'D BY	DRWN BY	TITLE
△			99/11/30	99/11/30	99/11/30	PALLET CHANGER (OPTION)
△			T. Inoue	M Okajima	M Okajima	PALLET SENSOR
△	Edition Oct.05.'00 M.Okajima					DRWN NO. 676 001 46522,0
△	Edition May.19.'00 M.Okajima					

This product is subject to all the applicable Japanese Foreign Exchange and Foreign Trade Law.
 本品は『外国為替及び外国貿易法』に該当しますので外国に輸出する場合には同法に基づく許可を必要とします。

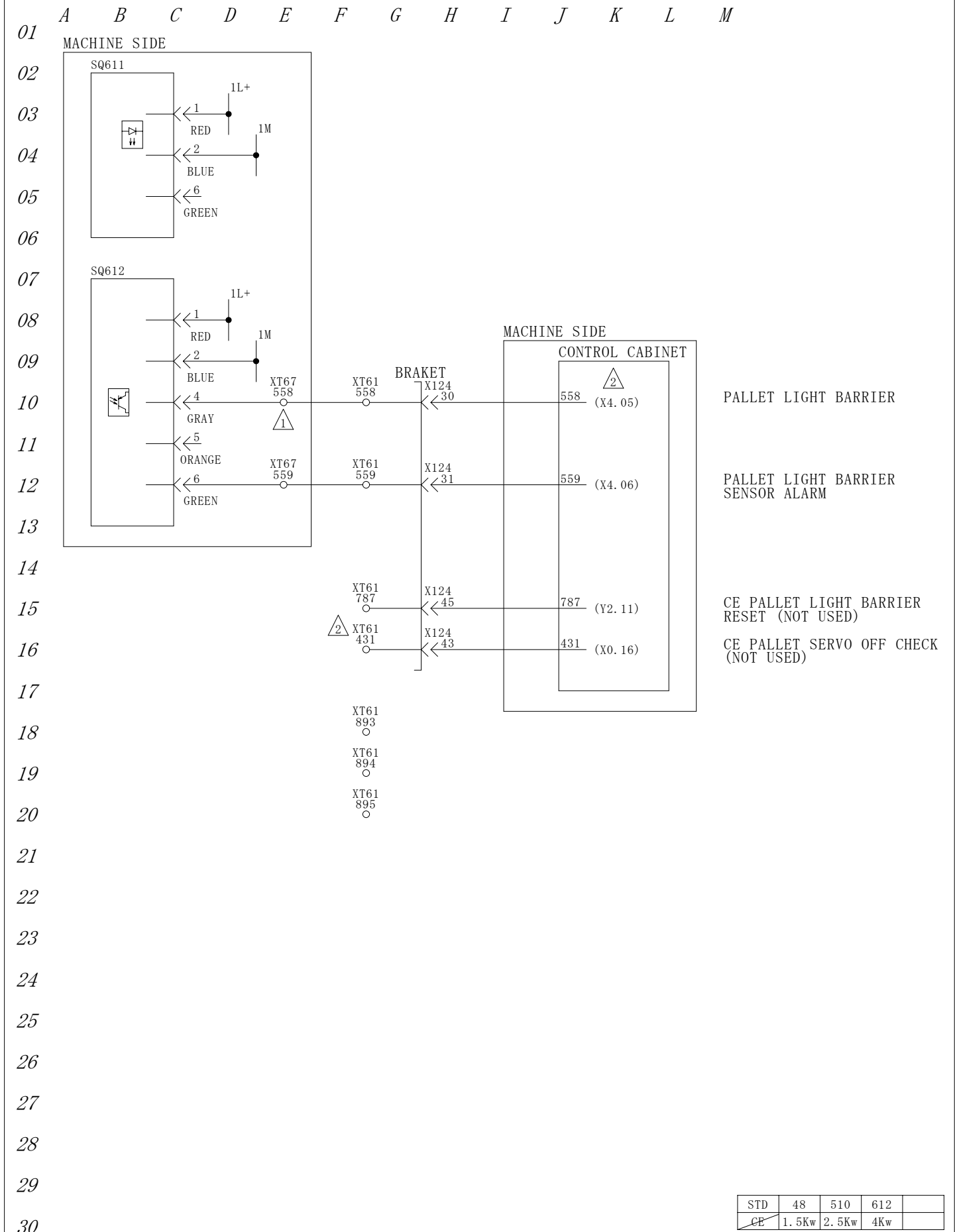

STD	48	510	612	
CE	1.5Kw	2.5Kw	4Kw	

△		 YAMAZAKI MAZAK CORPORATION	APR'D BY	CHK'D BY	DRWN BY	TITLE
△			99/11/30	99/11/30	99/11/30	PALLET CHANGER (OPTION) LIGHT BARRIER
△			T. Inoue	M Okajima	M Okajima	DRWN NO. 676 001 46602, 0
△	Edition Oct.05.'00 M.Okajima					
△	Edition May.30.'00 M.Okajima					

This product is subject to all the applicable Japanese Foreign Exchange and Foreign Trade Law.
 本品は『外国為替及び外国貿易法』に該当しますので外国に輸出する場合には同法に基づく許可を必要とします。

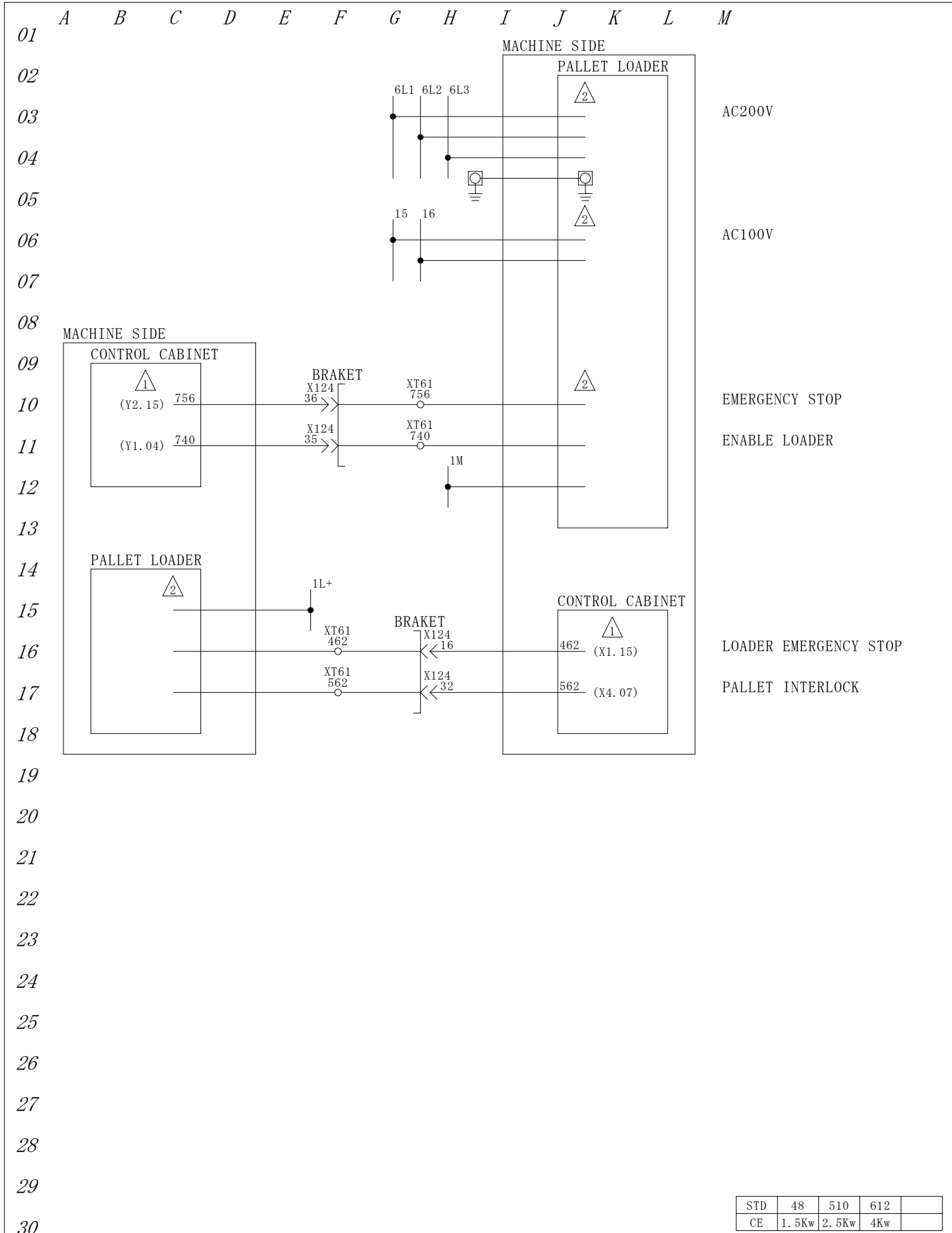

STD	48	510	612	
CE	1.5Kw	2.5Kw	4Kw	

△		 YAMAZAKI MAZAK CORPORATION	APR'D BY	CHK'D BY	DRWN BY	TITLE
△			99/11/30	99/11/30	99/11/30	PALLET CHANGER (OPTION) LOADER INTERFACE
△			T. Inoue	M Okajima	M Okajima	DRWN NO. 676 001 46901, 0
△			Edition Oct.05.'00 M.Okajima			

This product is subject to all the applicable Japanese Foreign Exchange and Foreign Trade Law.
 本品は『外国為替及び外国貿易法』に該当しますので外国に輸出する場合には同法に基づく許可を必要とします。

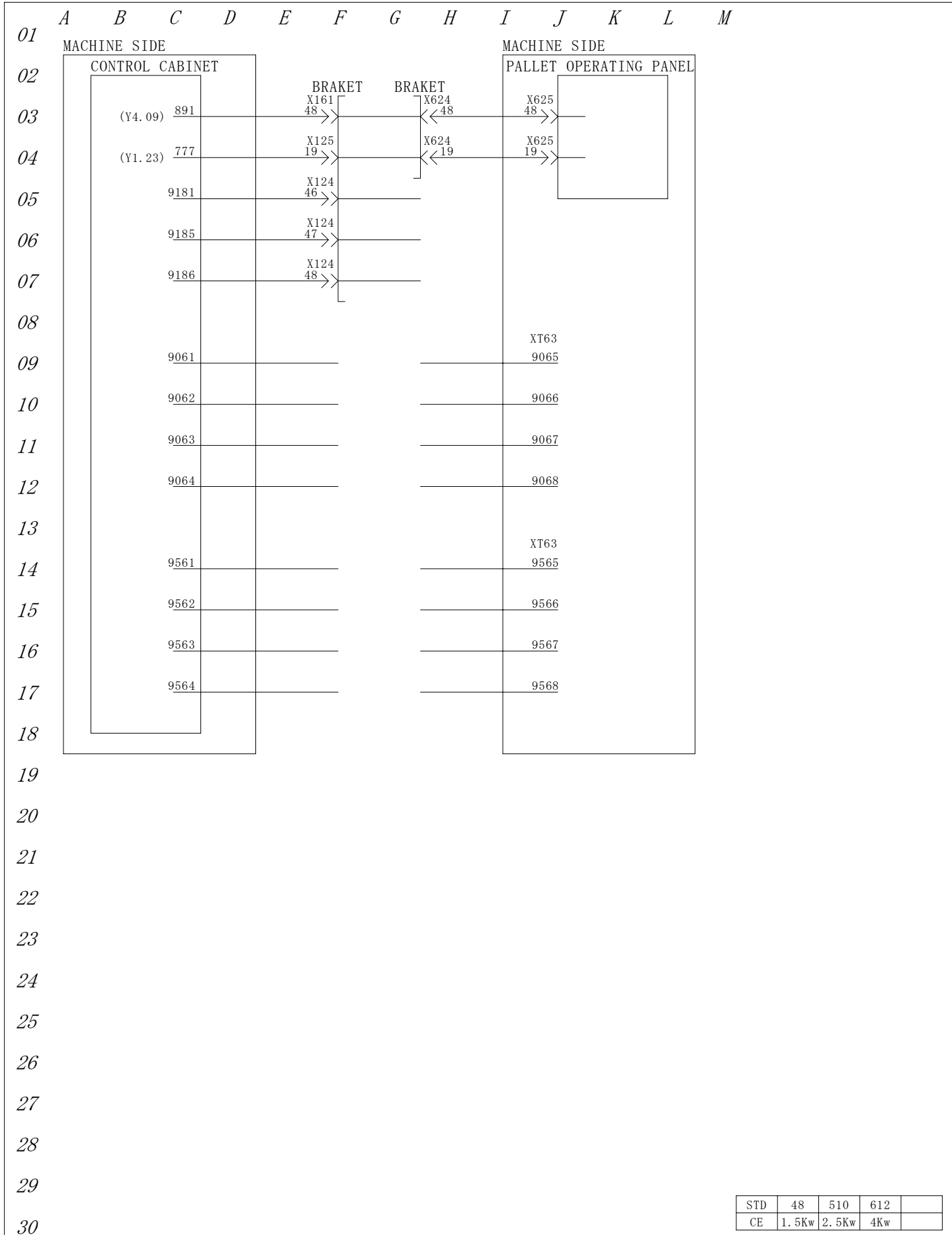

STD	48	510	612	
CE	1.5Kw	2.5Kw	4Kw	

△		 YAMAZAKI MAZAK CORPORATION	APR' D BY	CHK' D BY	DRWN BY	TITLE
△			99/11/30	99/11/30	99/11/30	PALLET CHANGER (OPTION) SPARE
△			T. Inoue	M Okaji ma	M Okaji ma	DRWN NO.
△						676 001 46950, 0
△						

This product is subject to all the applicable Japanese Foreign Exchange and Foreign Trade Law.
 本品は『外国為替及び外国貿易法』に該当しますので外国に輸出する場合には同法に基づく許可を必要とします。

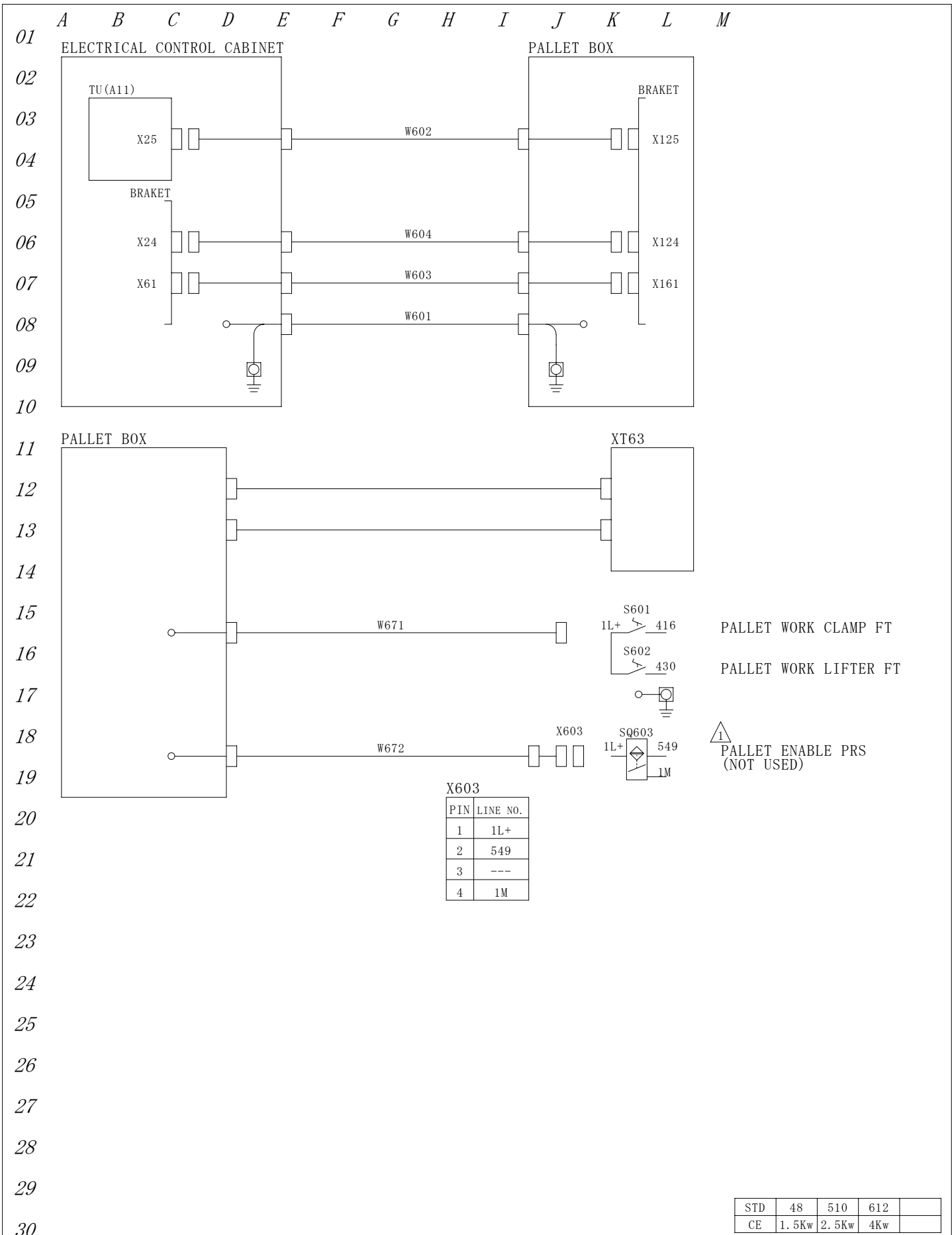

△		 YAMAZAKI MAZAK CORPORATION	APR'D BY 99/11/30 T. Inoue	CHK'D BY 99/11/30 M Okajima	DRWN BY 99/11/30 M Okajima	TITLE PALLET CHANGER (OPTION) PALLET BOX (1) DRWN NO. 676 001 36111, 0
△						
△						
△						

This product is subject to all the applicable Japanese Foreign Exchange and Foreign Trade Law.
 本品は『外国為替及び外国貿易法』に該当しますので外国に輸出する場合には同法に基づく許可を必要とします。

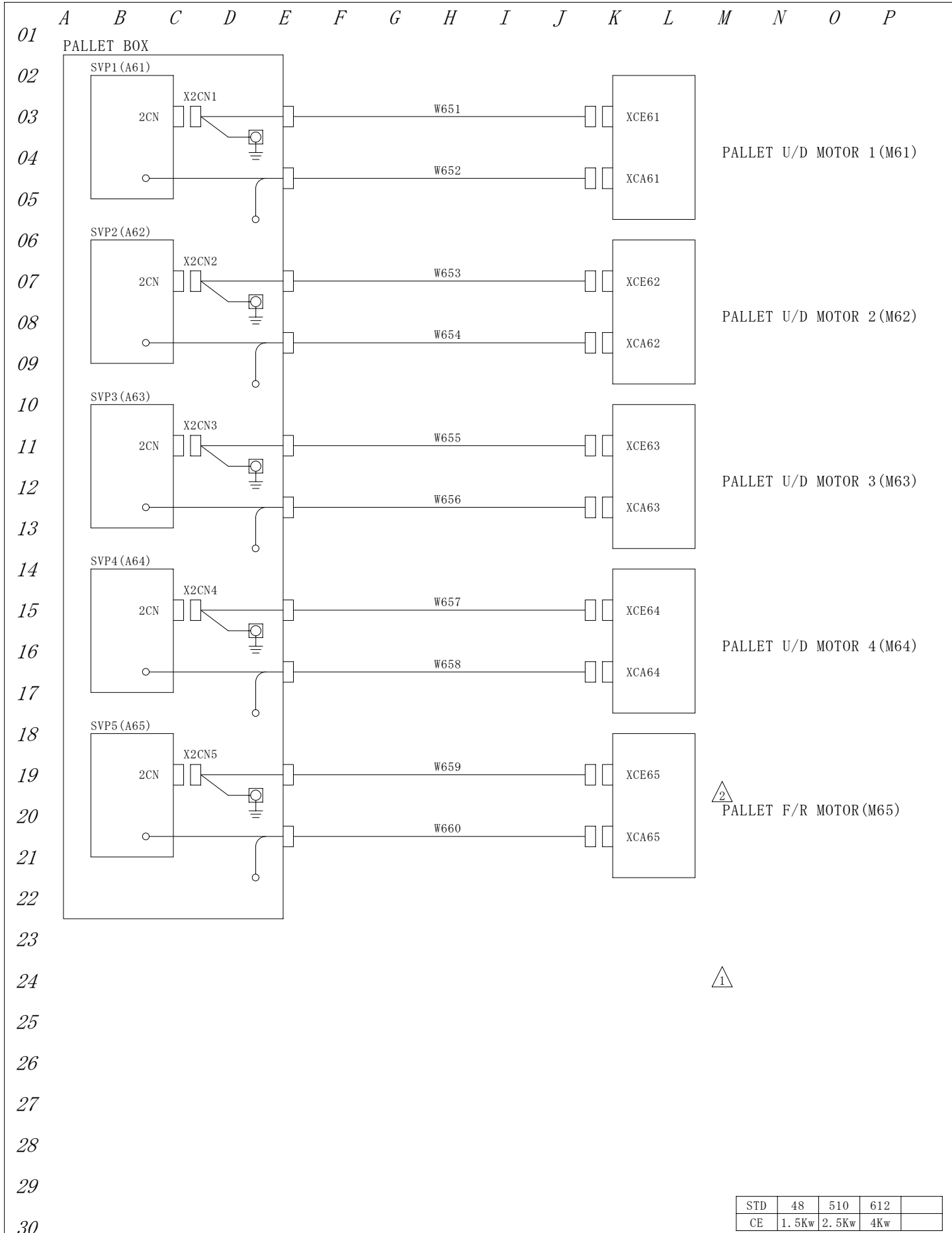

△₂ PALLET F/R MOTOR (M65)

△₁

STD	48	510	612	
CE	1.5Kw	2.5Kw	4Kw	

△		 YAMAZAKI MAZAK CORPORATION	APR'D BY	CHK'D BY	DRWN BY	TITLE
△			99/11/30	99/11/30	99/11/30	PALLET CHANGER (OPTION) PALLET BOX (2)
△			T. Inoue	M Okajima	M Okajima	DRWN NO.
△			676 001 36122, 0			

This product is subject to all the applicable Japanese Foreign Exchange and Foreign Trade Law.
 本品は『外国為替及び外国貿易法』に該当しますので外国に輸出する場合には同法に基づく許可を必要とします。

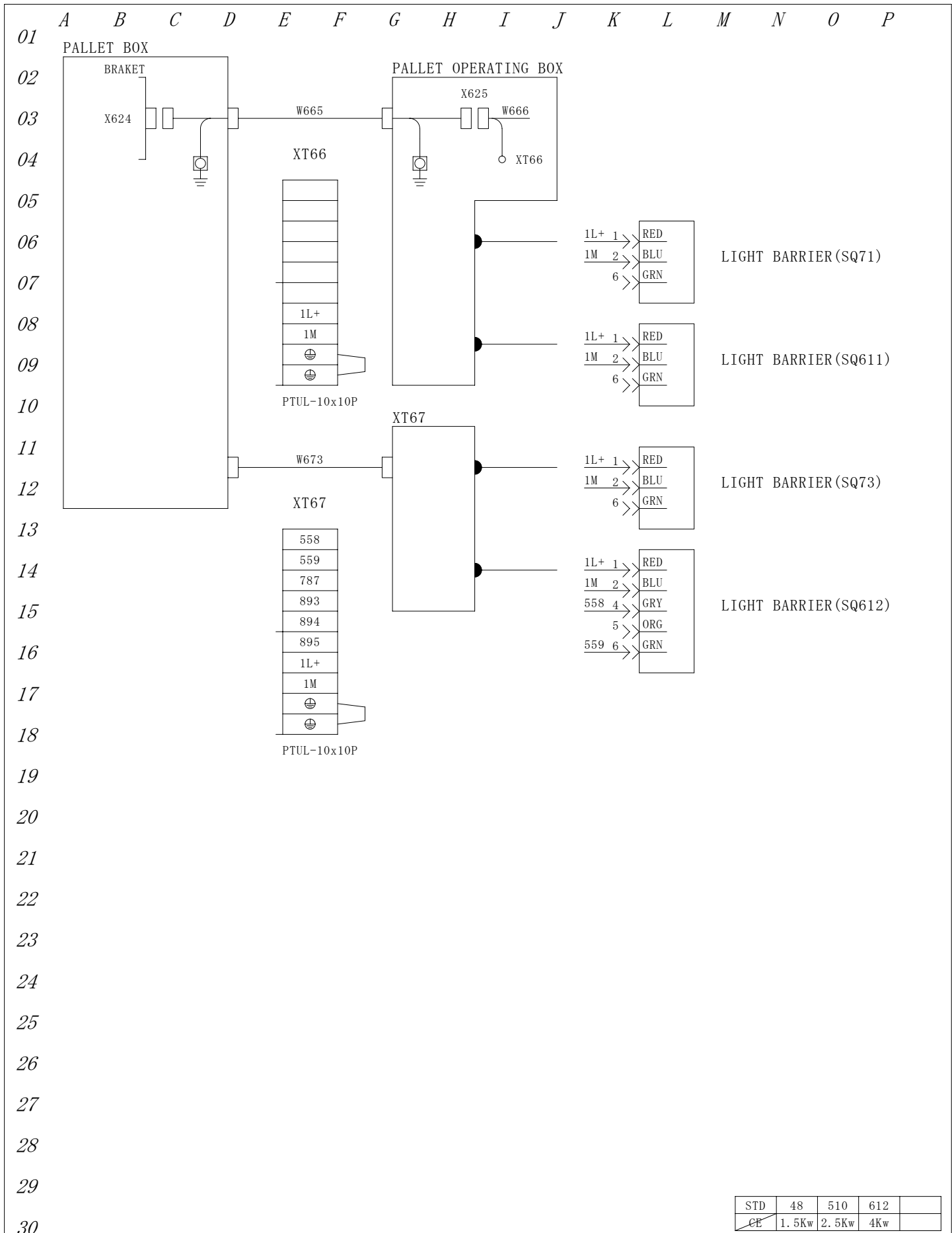

STD	48	510	612	
CE	1.5Kw	2.5Kw	4Kw	

△		 YAMAZAKI MAZAK CORPORATION	APR'D BY	CHK'D BY	DRWN BY	TITLE
△			99/11/30	99/11/30	99/11/30	PALLET CHANGER (OPTION)
△			T. Inoue	M Okajima	M Okajima	PALLET BOX (3)
△						DRWN NO.
△						676 001 36130, 0

This product is subject to all the applicable Japanese Foreign Exchange and Foreign Trade Law.
 本品は『外国為替及び外国貿易法』に該当しますので外国に輸出する場合には同法に基づく許可を必要とします。

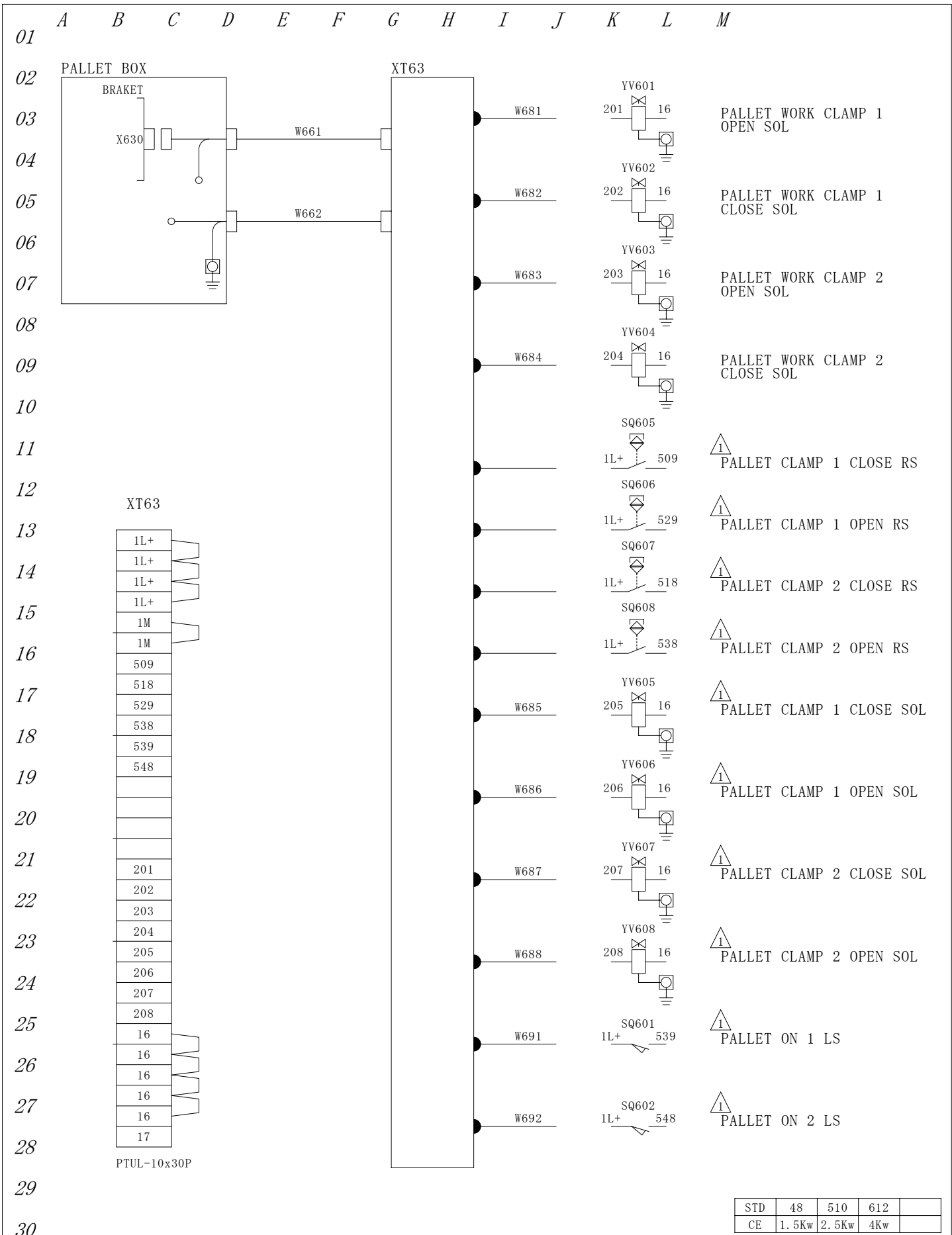

STD	48	510	612	
CE	1.5Kw	2.5Kw	4Kw	

△		 YAMAZAKI MAZAK CORPORATION	APR'D BY	CHK'D BY	DRWN BY	TITLE
△			99/11/30	99/11/30	99/11/30	PALLET CHANGER (OPTION) XT63
△			T. Inoue	M Okajima	M Okajima	DRWN NO. 676 001 36151, 0
△			Edition May.19.'00 M.Okajima			

This product is subject to all the applicable Japanese Foreign Exchange and Foreign Trade Law.
 本品は『外国為替及び外国貿易法』に該当しますので外国に輸出する場合には同法に基づく許可を必要とします。

01
02
03
04
05
06
07
08
09
10
11
12
13
14
15
16
17
18
19
20
21
22
23
24
25
26
27
28
29
30

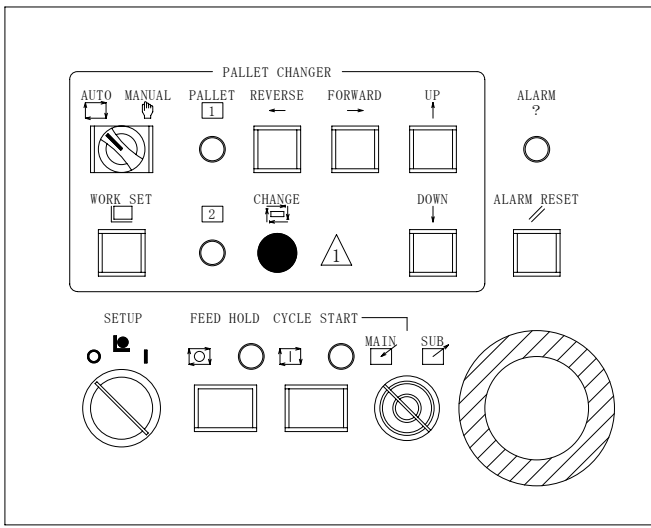

REAR CONNECTION

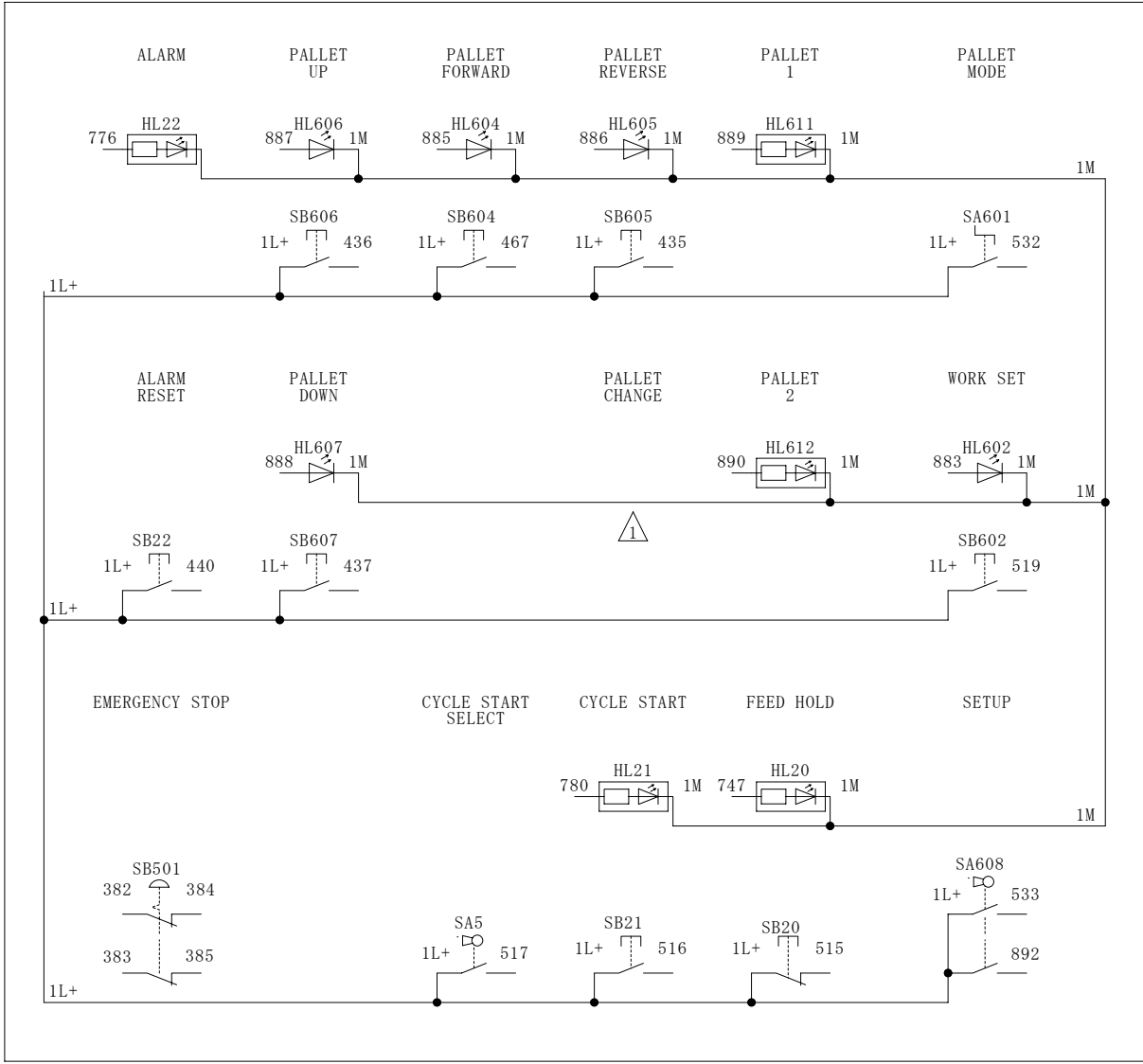

STD	48	510	612	
CE	1.5Kw	2.5Kw	4Kw	

	<p>Edition Jun. 28. '00 M. Okajima</p>	<p>YAMAZAKI MAZAK CORPORATION</p>	<p>APR' D BY 99/11/30 T. Inoue</p>	<p>CHK' D BY 99/11/30 M Okajima</p>	<p>DRWN BY 99/11/30 M Okajima</p>	<p>TITLE PALLET CHANGER (OPTION) OPERATING PANEL LAYOUT</p> <p>DRWN NO. 676 001 36171, 0</p>
--	--	-----------------------------------	--	---	---	--

This product is subject to all the applicable Japanese Foreign Exchange and Foreign Trade Law.
 本品は『外国為替及び外国貿易法』に該当しますので外国に輸出する場合には同法に基づく許可を必要とします。

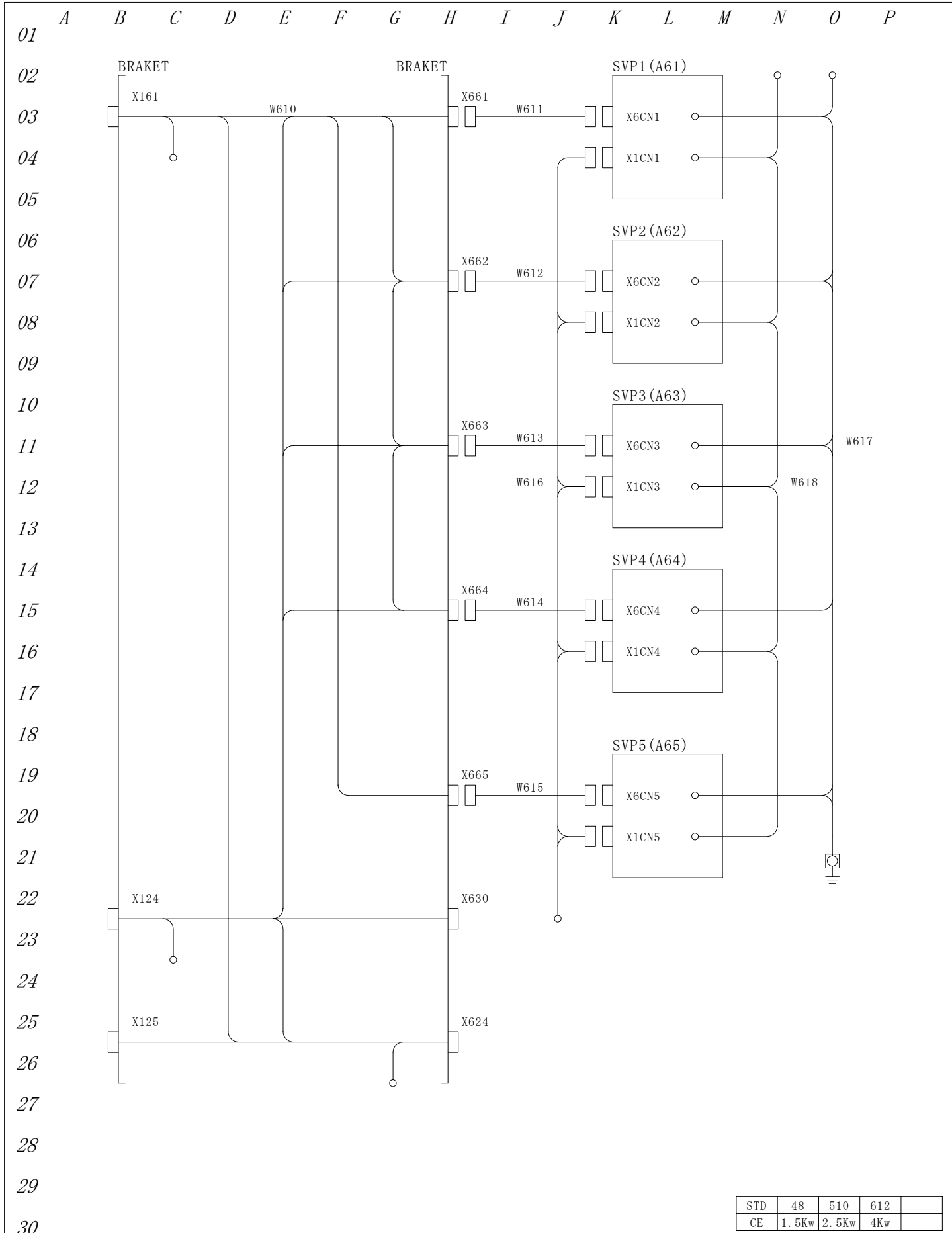

STD	48	510	612	
CE	1.5Kw	2.5Kw	4Kw	

				APR' D BY	CHK' D BY	DRWN BY	TITLE
				99/11/30	99/11/30	99/11/30	PALLET CHANGER (OPTION) PALLET BOX CONNECTION
				T. Inoue	M Okaji ma	M Okaji ma	DRWN NO.
							676 001 56110, 0

This product is subject to all the applicable Japanese Foreign Exchange and Foreign Trade Law.
 本品は『外国為替及び外国貿易法』に該当しますので外国に輸出する場合には同法に基づく許可を必要とします。

01 A B C D E F G H I J K L M N O P
PARTS LIST DIRECTORY

SPECIFICATIONS OF MACHINE		Mk II 48 JPN 1.5KW 1.8KW	Mk II 48 JPN 2.5KW	Mk II 48 JPN 4KW	Mk II 510 JPN 1.5KW 1.8KW	Mk II 510 JPN 2.5KW	Mk II 510 JPN 4KW	Mk II 612 JPN 1.5KW 1.8KW	Mk II 612 JPN 2.5KW	Mk II 612 JPN 4KW
STANDARD										
CABINET		A	B	C	A	B	C	A	B	C
OUTSIDE CABLE		A	B	C	D	E	F	G	H	J
TERMINAL BOX Δ	STD TYPE	A	A	A	A	A	A	A	A	A
	2PC TYPE	B	B	B	B	B	B	B	B	B
AUX. TRANS		---	---	---	---	---	---	---	---	---
Δ EXHAUST UNIT	PREPARATION	D	D	D	D	D	D	E	E	E
Δ GAP SENSOR	PREPARATION	D	D	D	D	D	D	D	D	D
OPTION										
HIGH PRESSURE GAS	HIGH PRESSURE (MANUAL) (NO SELECT SOL)	A	A	A	A	A	A	A	A	A
	4th ASSIST GAS (3rd&4th SELECT SOL)	B	B	B	B	B	B	B	B	B
	Δ H. P REGULATOR (NO SELECT SOL)	C	C	C	C	C	C	C	C	C
	Δ 4th ASSIST GAS (4th SELECT SOL)	D	D	D	D	D	D	D	D	D
	Δ H. P REGULATOR (3rd SELECT SOL)	E	E	E	E	E	E	E	E	E
	Δ HIGH PRESSURE (MANUAL) (3rd SELECT SOL)	F	F	F	F	F	F	F	F	F
EXHAUST UNIT	COVATRON	A	A	A	A	A	A	C	C	C
	SHINTO PXIII	B	B	B	B	B	B	B	B	B
GAP SENSOR Δ	NON CONTACT (MAZAK)	A	A	A	A	A	A	A	A	A
	POTENTIOMETER	C	C	C	C	C	C	C	C	C
RETRACE	NC RETRY	A	A	A	A	A	A	A	A	A
DNC INTERFACE		A	A	A	A	A	A	A	A	A
LOADER SENSOR		A	A	A	A	A	A	A	A	A
AUTO & ALARM POWER OFF		A	A	A	A	A	A	A	A	A
PROGRAMMABLE FOCUS		A	A	A	A	A	A	A	A	A
PIERCING ADAPTER		A	A	A	A	A	A	A	A	A
SIDE BLOW		A	A	A	A	A	A	A	A	A
THREE SIGNAL LIGHT		A	A	A	A	A	A	A	A	A
LEAK DETECTION BREAKER		A	B	C	A	B	C	A	B	C
ENCLOSURE COVER Δ	SLIDE COVER	A	A	A	B	B	B	C	C	C
	FIXED COVER	K	K	K	L	L	L	M	M	M
PALLET CHANGER		A	A	A	B	B	B	C	C	C

STD	48	510	612
CE	1.5Kw	2.5Kw	4Kw

Δ Edition Jun. 03. '04 M. Okajima	 YAMAZAKI MAZAK CORPORATION	APR' D BY	CHK' D BY	DRWN BY	TITLE
Δ Edition Mar. 03. '03 M. Okajima		99/11/30	99/11/30	99/11/30	PARTS LIST DIRECTORY (JAPAN)
Δ Edition Feb. 07. '02 M. Okajima		T. Inoue	M Okajima	M Okajima	DRWN NO.
Δ Edition Aug. 02. '01 M. Okajima		676 001 13015, 0			
Δ Edition Mar. 28. '00 M. Okajima					

This product is subject to all the applicable Japanese Foreign Exchange and Foreign Trade Law.
 本品は『外国為替及び外国貿易法』に該当しますので外国に輸出する場合には同法に基づく許可を必要とします。

01 A B C D E F G H I J K L M N O P
PARTS LIST DIRECTORY

SPECIFICATIONS OF MACHINE		Mk II 48 EXP 1.5KW 1.8KW	Mk II 48 EXP 2.5KW	Mk II 48 EXP 4KW	Mk II 510 EXP 1.5KW 1.8KW	Mk II 510 EXP 2.5KW	Mk II 510 EXP 4KW	Mk II 612 EXP 1.5KW 1.8KW	Mk II 612 EXP 2.5KW	Mk II 612 EXP 4KW
STANDARD										
CABINET		D	E	F	D	E	F	D	E	F
OUTSIDE CABLE		A	B	C	D	E	F	G	H	J
TERMINAL BOX \triangle	STD TYPE	A	A	A	A	A	A	A	A	A
	2PC TYPE	B	B	B	B	B	B	B	B	B
AUX. TRANS		A	B	G	A	B	G	A	B	G
\triangle EXHAUST UNIT	PREPARATION	D	D	D	D	D	D	E	E	E
\triangle GAP SENSOR	PREPARATION	D	D	D	D	D	D	D	D	D
OPTION										
HIGH PRESSURE GAS	HIGH PRESSURE (MANUAL) (NO SELECT SOL)	A	A	A	A	A	A	A	A	A
	4th ASSIST GAS (3rd&4th SELECT SOL)	B	B	B	B	B	B	B	B	B
	\triangle H.P REGULATOR (NO SELECT SOL)	C	C	C	C	C	C	C	C	C
	\triangle 4th ASSIST GAS (4th SELECT SOL)	D	D	D	D	D	D	D	D	D
	\triangle H.P REGULATOR (3rd SELECT SOL)	E	E	E	E	E	E	E	E	E
	\triangle HIGH PRESSURE (MANUAL) (3rd SELECT SOL)	F	F	F	F	F	F	F	F	F
EXHAUST UNIT	COVATRON	A	A	A	A	A	A	C	C	C
	SHINTO PXIII	B	B	B	B	B	B	B	B	B
GAP SENSOR \triangle	NON CONTACT (MAZAK)	A	A	A	A	A	A	A	A	A
	POTENTIOMETER	C	C	C	C	C	C	C	C	C
RETRACE	NC RETRY	A	A	A	A	A	A	A	A	A
DNC INTERFACE		A	A	A	A	A	A	A	A	A
LOADER SENSOR		A	A	A	A	A	A	A	A	A
AUTO & ALARM POWER OFF		A	A	A	A	A	A	A	A	A
PROGRAMMABLE FOCUS		A	A	A	A	A	A	A	A	A
PIERCING ADAPTER		A	A	A	A	A	A	A	A	A
SIDE BLOW		A	A	A	A	A	A	A	A	A
THREE SIGNAL LIGHT		A	A	A	A	A	A	A	A	A
LEAK DETECTION BREAKER		A	B	C	A	B	C	A	B	C
ENCLOSURE COVER \triangle	SLIDE COVER	A	A	A	B	B	B	C	C	C
	FIXED COVER	K	K	K	L	L	L	M	M	M
PALLET CHANGER		A	A	A	B	B	B	C	C	C

STD	48	510	612
CE	1.5Kw	2.5Kw	4Kw

\triangle Edition Jun. 03. '04 M. Okajima	 YAMAZAKI MAZAK CORPORATION	APR' D BY	CHK' D BY	DRWN BY	TITLE
\triangle Edition Mar. 03. '03 M. Okajima		99/11/30	99/11/30	99/11/30	PARTS LIST DIRECTORY (EXPORT)
\triangle Edition Feb. 07. '02 M. Okajima		T. Inoue	M Okajima	M Okajima	DRWN NO. 676 001 13025, 0
\triangle Edition Aug. 02. '01 M. Okajima					
\triangle Edition Mar. 28. '00 M. Okajima					

This product is subject to all the applicable Japanese Foreign Exchange and Foreign Trade Law.
 本品は『外国為替及び外国貿易法』に該当しますので外国に輸出する場合には同法に基づく許可を必要とします。

01 A B C D E F G H I J K L M N O P
PARTS LIST

02	PA CA	PARTS No.	PARTS NAME & DATA	CATALOGUE TYPE	SUPPLYER	ITEM	QUANTITY											
							A	B	C	D	E	F	G	H	J			
03	△2	D51MA 009110	NO FUSE BREAKER	NF225-CP 3P 150A SHT	MITUBISHI	QF1	1											
04		D51MA 010910	do	NF225-CP 3P 125A SHT	do	do	1											
05	△2	D51MA 009120	do	NF225-CP 3P 225A SHT	do	do		1										
06		D51MA 009640	do	NF225-CP 3P 200A SHT	do	do		1										
07		D51MA 009200	OPERATING HANDLE	F2SP	do	do	1	1										
08		D51MA 004040	PACKING	FOR F2SP	do	do	1	1										
09		D51MA 009800	COVER	TCL-2SP3	do	do	1	1										
10																		
11	△2	D51MA 010600	NO FUSE BREAKER	NF400-CP 3P 300A SHT	MITUBISHI	QF1			1									
12		D51MA 012150	do	NF400-CP 3P 250A SHT	do	do			1									
13		D51MA 011090	OPERATING HANDLE	F4SP	do	do			1									
14		D51MA 006270	PACKING	FOR F4SP	do	do			1									
15		D51MA 011100	COVER	TCL-4SP3	do	do			1									
16		D43PA 001380	SPARK KILLER	XAB-1201	OKAYA	Z1	△2	1	1	1								
17		D53TD 004730	TERMINAL BLOCK	PTUL-20x2P	TOYO GIKEN	XT13		1	1	1								
18		D53TD 007150	TERMINAL BLOCK	PTL-150x3P	TOYO GIKEN	XT1				1				1				
19	△2	D53TD 007440	do	PTL-200x3P	do	do				1						1		
20		D53TD 007340	do	PTL-300x3P	do	do				1		1		1		1		1
21		D11TQ 000230	DOOR SWITCH	D2D-2000	OMRON	SQ201 SQ202		2	2	2	2	2	2	2	2	2	2	2
22		D56TR 001840	COOLING FAN	UTS450CW	TOYO	M100 M101		2	2	2	2	2	2	2	2	2	2	2
23		D56TY 001260	FINGER GUARD	A-30F-1	TOBISHI			4	4	4	4	4	4	4	4	4	4	4
24		D20ZZ 002570	SIGNAL LIGHT	AGD100-2-RY	ASAHI	△2 A111		1	1	1	1	1	1	1	1	1	1	1
25																		
26		398106 10660	EARTH BAR	20x270 t5	YAMAZAKI			1	1	1	1	1	1	1	1	1	1	1
27		466816 00590	do	20x110 t5	do			1	1	1								
28		D56YC 001580	MARK	⊕	YAMAZAKI			6	6	6	6	6	6	6	6	6	6	6
29		D56YC 000350	do	Ⓛ (41146091140)	do			1	1	1								
30		D56YC 000360	do	Ⓞ (41146091150)	do			1	1	1								
31		418261 29450	do	PE	do			1	1	1								
32		435761 32590	do	L1	do			1	1	1								
33		435761 32600	do	L2	do			1	1	1								
34		435761 32610	do	L3	do			1	1	1								
35		423462 92790	do	△	do			1	1	1								
36		D99YC 990310	do	Ⓞ	do											5	5	5
37		467118 00010	LABEL	REMOTE CONTROL	do			1	1	1	1	1	1	1	1	1	1	1
38		342662 33411	do	MAZAK CONTROL BOX	do			1	1	1	1	1	1	1	1	1	1	1
39	△1	Z21TU 001170	GROMMET	C-30-SG-60A	TAKIGEN			1	1	1	1	1	1	1	1	1	1	1
40	△1	D64ZZ 004980	HOLE PLUG	DP-875	HEICO			19	19	19	19	19	19	19	19	19	19	19
41	△1	D64ZZ 005000	do	DP-1093	do			7	7	7	7	7	7	7	7	7	7	7
42	△1	D64ZZ 005030	do	DP-1375	do			2	2	2	2	2	2	2	2	2	2	2

STD	48	510	612
CE	1.5Kw	2.5Kw	4Kw

△		 YAMAZAKI MAZAK CORPORATION	APR' D BY	CHK' D BY	DRWN BY	TITLE
△			99/11/30	99/11/30	99/11/30	CABINET (1)
△	Edition Jan.16.'02 M.Okajima		T. Inoue	M Okaji ma	M Okaji ma	DRWN NO.
△	Edition Aug.02.'01 M.Okajima					676 001 13103, 0

This product is subject to all the applicable Japanese Foreign Exchange and Foreign Trade Law.
 本品は『外国為替及び外国貿易法』に該当しますので外国に輸出する場合には同法に基づく許可を必要とします。

01 A B C D E F G H I J K L M N O P
PARTS LIST

02	PA CA	PARTS No.	PARTS NAME & DATA	CATALOGUE TYPE	SUPPLYER	ITEM	QUANTITY													
							A	B	C	D	E	F	G	H	J					
03			[CB PANEL]																	
04	△3	D51MA 009090	NO FUSE BREAKER	NF100-CP 3P 100A	mitsubishi	QF2	1			1					1					
		D51MA 009500	do	NF100-CP 3P 75A	do	do	1			1					1					
05		D51MA 009420	COVER	TCS-1SP3	do	do	1			1					1					
06	△3	D51MA 009520	NO FUSE BREAKER	NF225-CP 3P 150A	do	do		1			1					1				
07	△3	D51MA 009510	do	NF225-CP 3P 125A	do	do		1			1					1				
		D51MA 009540	do	NF225-CP 3P 200A	do	do				1			1						1	
		D51MA 009530	do	NF225-CP 3P 175A	do	do				1			1						1	
		D51MA 009430	COVER	TCS-2SP3	do	do		1	1		1	1				1	1			1
08		D51MA 009490	NO FUSE BREAKER	NF100-CP 3P 60A	mitsubishi	QF3	1			1					1					
09		D51MA 009090	do	NF100-CP 3P 100A	do	do		1			1					1				
		D51MA 009420	COVER	TCS-1SP3	do	do	1	1			1	1				1	1			
10	△2	D51MA 009520	NO FUSE BREAKER	NF225-CP 3P 150A	do	do				1					1					1
	△3	D51MA 009510	do	NF225-CP 3P 125A	do	do				1					1					1
		D51MA 009430	COVER	TCS-2SP3	do	do				1					1					1
11																				
12		D51MA 008580	NO FUSE BREAKER	NF30-CS 3P 30A	mitsubishi	QF4	1	1	1	1	1	1	1	1	1	1	1	1	1	1
		D51MA 008450	COVER	TCS-03CS3	do	do	1	1	1	1	1	1	1	1	1	1	1	1	1	1
13		D51MA 008590	NO FUSE BREAKER	NF30-CS 2P 10A	mitsubishi	QF5	1	1	1	1	1	1	1	1	1	1	1	1	1	1
		D51MA 009720	COVER	TCS-03CS2	do	do	1	1	1	1	1	1	1	1	1	1	1	1	1	1
14		D51MA 009610	NO FUSE BREAKER	NF50-CP 3P 40A	mitsubishi	QF6	1	1	1	1	1	1	1	1	1	1	1	1	1	1
		D51MA 009250	COVER	TCS-05SP3	do	do	1	1	1	1	1	1	1	1	1	1	1	1	1	1
15		D01MA 057620	MAGNET CONTACTOR	MS0-2XN11CXKP 2.1A AC100V 1aX2	mitsubishi	KM100 KM101 FR100	1	1	1	1	1	1	1	1	1	1	1	1	1	1
16		D43PA 001390	SPARK KILLER	3CRE-50500	OKAYA	Z61	1	1	1	1	1	1	1	1	1	1	1	1	1	1
17		D43PA 001380	do	XAB-1201	do	Z100, 101	2	2	2	2	2	2	2	2	2	2	2	2	2	2
18	△3	D02MA 006570	MAGNET CONTACTOR	S-N11CX AC100V 1a	mitsubishi	KM102	1	1	1	1	1	1	1	1	1	1	1	1	1	1
		D43PA 001380	SPARK KILLER	XAB-1201	OKAYA	Z102	1	1	1	1	1	1	1	1	1	1	1	1	1	1
19	△4	D04TC 000100	RELAY	LY2 DC24V	OMRON	KA20, 32	9	9	9	9	9	9	9	9	9	9	9	9	9	9
20	△4	D04TC 001900	SOCKET	PTF08A-E	do	101, 102 103, 106	9	9	9	9	9	9	9	9	9	9	9	9	9	9
	△4	D04TC 001170	HOLDER	PYC-A1	do	107, 115 190	9	9	9	9	9	9	9	9	9	9	9	9	9	9
21	△4	D34TA 001540	DIODE	S5277G	TOSHIBA	V20, 32 101, 102 103, 106 107, 115 190	9	9	9	9	9	9	9	9	9	9	9	9	9	9
22																				
23	△1	D27NM 000270	SSR BOARD	D2N103LG33QB4	NIHON INTER	A13	1	1	1	1	1	1	1	1	1	1	1	1	1	1
		323426 41220	SSR BOARD COVER		YAMAZAKI	do	1	1	1	1	1	1	1	1	1	1	1	1	1	1
24		D53TD 004720	TERMINAL BLOCK	PTUL-40x6P	TOYO GIKEN	XT2, 14	2	2	2	2	2	2	2	2	2	2	2	2	2	2
		D53TD 005330	do	PTUL-10x50P	do	XT3	1	1	1	1	1	1	1	1	1	1	1	1	1	1
25	△4	D43PA 001380	SPARK KILLER	XAB-1201	OKAYA	Z1, 6 17, 18 60, 106 32, 35 66	9	9	9	9	9	9	9	9	9	9	9	9	9	9
26																				
27		466019 00071	EARTH BAR	20x120 t5	YAMAZAKI		1	1	1	1	1	1	1	1	1	1	1	1	1	1
28		D56YC 001580	EARTH MARK	⊕	do		2	2	2	2	2	2	2	2	2	2	2	2	2	2
29																				

STD	48	510	612
CE	1.5Kw	2.5Kw	4Kw

△	Edition Oct.10.'03 M.Okajima	 YAMAZAKI MAZAK CORPORATION	APR'D BY	CHK'D BY	DRWN BY	TITLE
△	Edition Aug.02.'01 M.Okajima		99/11/30	99/11/30	99/11/30	CABINET (2)
△	Edition Aug.10.'00 M.Okajima		T. Inoue	M Okaji ma	M Okaji ma	
△	Edition Mar.27.'00 M.Okajima					DRWN NO. 676 001 13114, 0

This product is subject to all the applicable Japanese Foreign Exchange and Foreign Trade Law.
 本品は『外国為替及び外国貿易法』に該当しますので外国に輸出する場合には同法に基づく許可を必要とします。

01 A B C D E F G H I J K L M N O P
PARTS LIST

02	PA CA	PARTS No.	PARTS NAME & DATA	CATALOGUE TYPE	SUPPLYER	ITEM	QUANTITY													
							A	B	C	D	E	F	G	H	J					
03			[CABLE]																	
04	△7	D71676 00011	PC INPUT CABLE	NC(XCS41) <->TU(X01, X02, X03, X04)	YAMAZAKI	W001	1	1	1	1	1	1	1	1	1	1	1	1	1	1
05	△7	D71676 00041	PC OUTPUT CABLE	NC(XCS43) <->TU(X06, X08)	do	W004	1	1	1	1	1	1	1	1	1	1	1	1	1	1
	△7	D71676 00051	do	NC(XCS44) <->TU(X07)	do	W005	1	1	1	1	1	1	1	1	1	1	1	1	1	1
06		D71676 00060	NC SKIP CABLE	NC(XCS46) <->TU(X09)	do	W006	1	1	1	1	1	1	1	1	1	1	1	1	1	1
	△5	D71676 00071	NC ANALOG CABLE	NC(XCT50, XCS33) <->STU(X15), TU(X86)	do	W007	1	1	1	1	1	1	1	1	1	1	1	1	1	1
07		D71676 00080	NC RS232C CABLE	NC(XCM2, XCM4) <->STU(X11)	do	W008	1	1	1	1	1	1	1	1	1	1	1	1	1	1
08		D71676 00090	NC HANDLE CABLE	NC(XCS45) <->PANEL(HANDLE)	do	W009	1	1	1	1	1	1	1	1	1	1	1	1	1	1
		D71676 00100	NC OP. PANEL CABLE	NC(XM1) <->PANEL(XC010)	do	W010	1	1	1	1	1	1	1	1	1	1	1	1	1	1
		D71676 00110	do	NC(XM8) <->PANEL(XCN1)	do	W011	1	1	1	1	1	1	1	1	1	1	1	1	1	1
09	△1	D71676 00151	NC POWER CABLE	XT4, EARTH<->NC(XT1001)	do	W015	1	1	1	1	1	1	1	1	1	1	1	1	1	1
10		D71676 00160	NC OP. PANEL POWER CABLE	NC(XT1001), EARTH <->NC OP. PANEL	do	W016	1	1	1	1	1	1	1	1	1	1	1	1	1	1
11		D71676 00170	OP. PANEL CABLE	NC OP. PANEL(XCP63, 64) <->OP. PANEL	do	W017	1	1	1	1	1	1	1	1	1	1	1	1	1	1
12		D71676 00210	NC SERVO CABLE	NC(XCS30) <->X AMP(XCA13)	do	W021	1	1	1	1	1	1	1	1	1	1	1	1	1	1
		D71676 00220	do	NC(XCS31) <->Y AMP(XCA23)	do	W022	1	1	1	1	1	1	1	1	1	1	1	1	1	1
13		D71676 00230	do	NC(XCS32) <->Z AMP(XCA33)	do	W023	1	1	1	1	1	1	1	1	1	1	1	1	1	1
	△1	D71676 00251	SERVO POWER CABLE	XT14, EARTH<->X, Y, Z AMP	do	W025	1	1	1	1	1	1	1	1	1	1	1	1	1	1
14	△2	D71676 00261	SERVO CONTROL CABLE	XT3, Z AMP<->X, Y, Z AMP	do	W026	1	1	1	1	1	1	1	1	1	1	1	1	1	1
	△4	D71676 00311	CB PANEL CABLE	TU(X81) <->CB PANEL	do	W031	1	1	1	1	1	1	1	1	1	1	1	1	1	1
15	△1	D71676 00321	RELAY CABLE	TU(X82) <->CB PANEL, NC	do	W032	1	1	1	1	1	1	1	1	1	1	1	1	1	1
		D71676 00330	SSR BOARD CABLE	TU(X83) <->SSR(XIN11, 12)	do	W033	1	1	1	1	1	1	1	1	1	1	1	1	1	1
16	△2	D71676 00342	CE CIRCUIT CABLE	TU(X84) <->TB PANEL	do	W034	1	1	1	1	1	1	1	1	1	1	1	1	1	1
	△2	D71676 00352	TB PANEL CABLE	TU(X85) <->TB PANEL	do	W035	1	1	1	1	1	1	1	1	1	1	1	1	1	1
17	△6	D71676 00361	STU CABLE	TU(X89) <->STU(X19)	do	W036	1	1	1	1	1	1	1	1	1	1	1	1	1	1
		D71676 00370	OPU CABLE	STU(X29) <->OPU(X291), XT5	do	W037	1	1	1	1	1	1	1	1	1	1	1	1	1	1
18		D71676 00380	I/O RS232C CABLE	STU(X12) <->I/O PANEL(X232)	do	W038	1	1	1	1	1	1	1	1	1	1	1	1	1	1
		D71676 00390	I/O PANEL AC CABLE	XT4, EARTH<->I/O PANEL	do	W039	1	1	1	1	1	1	1	1	1	1	1	1	1	1
19	△1	D71676 00401	SIGNAL LIGHT CABLE	SSR BOARD<->SIGNAL LIGHT	do	W040	1	1	1	1	1	1	1	1	1	1	1	1	1	1
		D71676 00410	DC SUPPLY AC CABLE	XT4, EARTH<->GS1, GS2	do	W041	1	1	1	1	1	1	1	1	1	1	1	1	1	1
20		D71676 00420	DC SUPPLY DC CABLE	GS1, GS2<->TU(X80) STU(X10)	do	W042	1	1	1	1	1	1	1	1	1	1	1	1	1	1
21	△7	D71676 00511	PC OUTPUT CABLE	NC(XCT53) <->BRACKET(X61)	do	W051	1	1	1	1	1	1	1	1	1	1	1	1	1	1
		D71676 00520	NC OP. PANEL CABLE	TU(X21, 22) <->OP. PANEL, BRACKET(X24), XT5	do	W052	1	1	1	1	1	1	1	1	1	1	1	1	1	1
22	△6	D71676 00533	SPARE CABLE	TU(X87, 88) <->XT5	do	W053	1	1	1	1	1	1	1	1	1	1	1	1	1	1
23																				
24																				
25																				
26																				
27																				
28																				
29																				

△		△		STD	48	510	612
△	Edition Oct.10.'03 M.Okajima	△	Edition Feb.21.'04 M.Okajima	CE	1.5Kw	2.5Kw	4Kw

△	Edition Feb.05.'02 M.Okajima	 YAMAZAKI MAZAK CORPORATION	APR'D BY	CHK'D BY	DRWN BY	TITLE
△	Edition Aug.02.'01 M.Okajima		99/11/30	99/11/30	99/11/30	CABINET(4)
△	Edition Jul.17.'00 M.Okajima		T. Inoue	M Okajima	M Okajima	DRWN NO. 676 001 13137, 0
△	Edition Apr.07.'00 M.Okajima					
△	Edition Mar.28.'00 M.Okajima					

This product is subject to all the applicable Japanese Foreign Exchange and Foreign Trade Law.
 本品は『外国為替及び外国貿易法』に該当しますので外国に輸出する場合には同法に基づく許可を必要とします。

01 A B C D E F G H I J K L M N O P
PARTS LIST

02	PA CA	PARTS No.	PARTS NAME & DATA	CATALOGUE TYPE	SUPPLYER	ITEM	QUANTITY								
							D	E	F	N	P	Q			
03	△1	D71677 10011	X ENCODER CABLE	CABINET<->X MOTOR	YAMAZAKI	W101	1	1	1	1	1	1			
04	△1	D71677 10021	X MOTOR CABLE	do	do	W102	1	1	1	1	1	1			
	△1	D71677 10031	Y ENCODER CABLE	CABINET<->Y MOTOR	do	W103	1	1	1	1	1	1			
05	△1	D71677 10041	Y MOTOR CABLE	do	do	W104	1	1	1	1	1	1			
	△3	D71677 10051	Z ENCODER CABLE	CABINET<->Z MOTOR	do	W105	1	1	1	1	1	1			
06	△1	D71677 10061	Z MOTOR CABLE	do	do	W106	1	1	1	1	1	1			
		D71677 10100	LASER POWER CABLE	CABINET<->LASER (1.5KW)	do	W110	1								
07	△1	D71677 11101	do	CABINET<->LASER (2.5KW)	do	do		1			△7				
	△1	D71677 12101	do	CABINET<->LASER (4KW)	do	do			1						
08	△7	D71677 13100	do	CABINET<->LASER (1.5KW)	do	do				1					
	△7	D71677 14100	do	CABINET<->LASER (2.5KW)	do	do					1				
09	△7	D71677 15100	do	CABINET<->LASER (4KW)	do	do						1			
	△1	D71677 10111	LASER SIGNAL CABLE	CABINET<->LASER (XL1C)	do	W111	1	1	1	1	1	1			
10	△6	D71676 10151	CHILLER CABLE	CABINET<->CHILLER (1.5KW)	do	W115	1								
	△6	D71676 11152	do	CABINET<->CHILLER (2.5KW)	do	do		1							
11	△6	D71676 12152	do	CABINET<->CHILLER (4KW)	do	do			1						
	△6	D71676 13151	do	CABINET<->CHILLER (1.5KW)	do	do				1					
12	△6	D71676 14151	do	CABINET<->CHILLER (2.5KW)	do	do					1				
	△6	D71676 15151	do	CABINET<->CHILLER (4KW)	do	do						1			
13	△1	D71677 10201	XT31 DC CABLE	CABINET<->XT31	do	W120	1	1	1	1	1	1			
	△1	D71677 10211	XT31 AC CABLE	do	do	W121	1	1	1	1	1	1			
14	△1	D71677 10221	XT51 DC CABLE	CABINET<->XT51	do	W122	1	1	1	1	1	1			
	△1	D71677 10241	XT71 DC CABLE	CABINET<->XT71	do	W124	1	1	1	1	1	1			
15	△1	D71677 10251	XT71 AC CABLE	do	do	W125	1	1	1	1	1	1			
	△8	D71677 10301	CHIP CONVEYER CABLE	CABINET<->CHIP CONVEYER	do	W130	1	1	1	1	1	1			
16	△1	D71676 10311	FOOT SW CABLE	CABINET<->FOOT SW	do	W131	1	1	1						
		D71676 13310	do	do	do	do				1	1	1			
17	△7	D71676 10332	WORK LIGHT CABLE	CABINET<->WORK LIGHT	do	W133	1	1	1	1	1	1			
	△3	D71676 10352	SQ25,506 CABLE	CABINET<->SIDE COVER LS	do	W135	1	1	1						
18	△3	D71676 13351	do	do	do	do				1	1	1			
	△8	D71677 11300	CHIP CONVEYER CABLE	CABINET<->CHIP CONVEYER	do	W130	1	1	1	1	1	1			
19															
20															
21															
22															
23															
24															
25															
26															
27															
28															

△1	Edition May.06.'03 M.Okajima	△9		STD	48	510	612
△1	Edition Aug.03.'01 M.Okajima	△9	Edition Dec.27.'01 M.Okajima	CE	1.5Kw	2.5Kw	4Kw

△1	Edition Oct.10.'00 M.Okajima	 YAMAZAKI MAZAK CORPORATION	APR'D BY	CHK'D BY	DRWN BY	TITLE
△1	Edition Aug.25.'00 M.Okajima		99/11/30	99/11/30	99/11/30	OUTSIDE CABLE(1)
△1	Edition Aug.13.'00 M.Okajima		T. Inoue	M Okajima	M Okajima	(510Mk II)
△1	Edition May.24.'00 M.Okajima					DRWN NO.
△1	Edition Mar.28.'00 M.Okajima					676 001 13238, 0

This product is subject to all the applicable Japanese Foreign Exchange and Foreign Trade Law.
 本品は『外国為替及び外国貿易法』に該当しますので外国に輸出する場合には同法に基づく許可を必要とします。

01 A B C D E F G H I J K L M N O P
PARTS LIST

PA CA	PARTS No.	PARTS NAME & DATA	CATALOGUE TYPE	SUPPLYER	ITEM	QUANTITY											
						A	B	C	D	E	F	G	H	J			
△	D51MA 009110	NO FUSE BREAKER	NF225-CP 3P 150A SHT	MITUBISHI	QF1	1											
	D51MA 010910	do	NF225-CP 3P 125A SHT	do	do	1											
△	D51MA 009120	do	NF225-CP 3P 225A SHT	do	do		1										
	D51MA 009640	do	NF225-CP 3P 200A SHT	do	do		1										
	D51MA 009200	OPERATING HANDLE	F2SP	do	do	1	1										
	D51MA 004040	PACKING	FOR F2SP	do	do	1	1										
	D51MA 009800	COVER	TCL-2SP3	do	do	1	1										
△	D51MA 010600	NO FUSE BREAKER	NF400-CP 3P 300A SHT	MITUBISHI	QF1			1									
	D51MA 012150	do	NF400-CP 3P 250A SHT	do	do			1							1		
	D51MA 011090	OPERATING HANDLE	F4SP	do	do			1							1		
	D51MA 006270	PACKING	FOR F4SP	do	do			1							1		
	D51MA 011100	COVER	TCL-4SP3	do	do			1							1		
	D51MA 009630	NO FUSE BREAKER	NF100-SP 3P 75A SHT	MITUBISHI	QF1				1								
	D51MA 009220	OPERATING HANDLE	V1SPF	do	do				1								
	D51MA 009470	COVER	TCL-1SP3	do	do				1								
	D51MA 009820	NO FUSE BREAKER	NF225-SP 3P 125A SHT	MITUBISHI	QF1					1							
	D51MA 009310	NO FUSE BREAKER	NF225-SP 3P 150A SHT	do	do						1						
	D51MA 009230	OPERATING HANDLE	V2SPF	do	do					1	1						
	D51MA 009800	COVER	TCL-2SP3	do	do					1	1						
	D43PA 001380	SPARK KILLER	XAB-1201	OKAYA	Z1	△	1	1	1	1	1	1					
	D53TD 004730	TERMINAL BLOCK	PTUL-20x2P	TOYO GIKEN	XT13		1	1	1	1	1	1	1				
	D56YC 001580	MARK	⊕	YAMAZAKI			1	1	1	1	1	1	1				
	D56YC 000350	do	① (41146091140)	do			1	1	1	1	1	1	1				
	D56YC 000360	do	② (41146091150)	do			1	1	1	1	1	1	1				
	418261 29450	do	PE	do			1	1	1	1	1	1	1				
	435761 32590	do	L1	do			1	1	1	1	1	1	1				
	435761 32600	do	L2	do			1	1	1	1	1	1	1				
	435761 32610	do	L3	do			1	1	1	1	1	1	1				
	423462 92790	do	△	do			1	1	1	1	1	1	1				
△	D99YC 990310	do	⊕	do						1	1	1					

STD	48	510	612
CE	1.5Kw	2.5Kw	4Kw

△		 YAMAZAKI MAZAK CORPORATION	APR'D BY	CHK'D BY	DRWN BY	TITLE
△			99/11/30	99/11/30	99/11/30	AUX. TRANSFORMER(1)
△			T. Inoue	M Okajima	M Okajima	(EXPORT)
△			Edition Jan.16.'02 M.Okajima			DRWN NO. 676 001 13402.0
△		Edition Aug.03.'01 M.Okajima				

This product is subject to all the applicable Japanese Foreign Exchange and Foreign Trade Law.
 本品は『外国為替及び外国貿易法』に該当しますので外国に輸出する場合には同法に基づく許可を必要とします。

01 A B C D E F G H I J K L M N O P
PARTS LIST

02	PA CA	PARTS No.	PARTS NAME & DATA	CATALOGUE TYPE	SUPPLYER	ITEM	QUANTITY											
							A	B	C	D	E	F	G	H	J			
03	△2	D71676 10402	AUX. TRANS CABLE	CABINET<->TRANS BOX(TM1)	YAMAZAKI	W140	1											
04	△2	D71676 11402	do	do	do	do		1										
	△2	D71676 12403	do	do	do	do			1					1				
05	△3	D71676 13403	do	do	do	do				1								
	△3	D71676 14403	do	do	do	do					1							
06	△3	D71676 15403	do	do	do	do						1						
	△2	D71676 10411	do	QF1<->TM1	do	W141	1											
07	△2	D71676 11411	do	do	do	do		1										
		D71676 12410	do	do	do	do			1									
08	△2	D71676 12440	do	do	do	do									1			
	△1	D71676 13411	do	Z10<->TM1	do	W141				1								
09	△1	D71676 14411	do	do	do	do					1							
	△1	D71676 15411	do	do	do	do							1					
10	△3	D71676 13422	do	QF1<->Z10	do	W142				1								
	△3	D71676 14422	do	do	do	do					1							
11	△3	D71676 15422	do	do	do	do								1				
12																		
13																		
14																		
15																		
16																		
17																		
18																		
19																		
20																		
21																		
22																		
23																		
24																		
25																		
26																		
27																		
28																		

STD	48	510	612
CE	1.5Kw	2.5Kw	4Kw

△		 YAMAZAKI MAZAK CORPORATION	APR'D BY	CHK'D BY	DRWN BY	TITLE
△			99/11/30	99/11/30	99/11/30	AUX. TRANSFORMER(2) (EXPORT)
△	Edition Jan.11.'02 M.Okajima		T. Inoue	M Okajima	M Okajima	DRWN NO. 676 001 13413, 0
△	Edition Aug.03.'01 M.Okajima					
△	Edition Aug.23.'00 M.Okajima					

This product is subject to all the applicable Japanese Foreign Exchange and Foreign Trade Law.
 本品は『外国為替及び外国貿易法』に該当しますので外国に輸出する場合には同法に基づく許可を必要とします。

01 A B C D E F G H I J K L M N O P

PARTS LIST

△₂ △₃ △₃ △₃

PA CA	PARTS No.	PARTS NAME & DATA	CATALOGUE TYPE	SUPPLYER	ITEM	QUANTITY														
						A	B	C	D	E	F	G	H	J						
△ ₁	D71676 50111	YV23 CABLE	XT71<->ASSIST GAS HIGH SOL	YAMAZAKI	W511	1						1								
	D64ND 005080	NIPO SHEEL	NPS-1608	NIPPON FLEX		1		2		2	1									
△ ₁	D71676 50121	YV26 CABLE	XT31<->3rd GAS SELECT SOL	YAMAZAKI	W512		1				1	1								
△ ₁	D71676 50131	YV27 CABLE	XT31<->4th GAS SELECT SOL	do	W513		1		1											
△ ₂	D71676 50140	YV89 CABLE	XT71<->ASSIST GAS EXHAUST SOL	do	W514				1		1									
08																				
09																				
10																				
11																				
12																				
13																				
14																				
15																				
16																				
17																				
18																				
19																				
20																				
21																				
22																				
23																				
24																				
25																				
26																				
27																				
28																				

STD	48	510	612	
CE	1.5Kw	2.5Kw	4Kw	

△		 YAMAZAKI MAZAK CORPORATION	APR'D BY	CHK'D BY	DRWN BY	TITLE
△			99/11/30	99/11/30	99/11/30	HIGH PRESSURE GAS (OPTION)
△	Edition Mar.03.'03 M.Okajima		T. Inoue	M Okajima	M Okajima	DRWN NO.
△	Edition Feb.05.'02 M.Okajima					676 001 13503,0

This product is subject to all the applicable Japanese Foreign Exchange and Foreign Trade Law.
 本品は『外国為替及び外国貿易法』に該当しますので外国に輸出する場合には同法に基づく許可を必要とします。

01 A B C D E F G H I J K L M N O P

PARTS LIST

△ △ △

PA CA	PARTS No.	PARTS NAME & DATA	CATALOGUE TYPE	SUPPLYER	ITEM	QUANTITY														
						A	B	C	D	E	F	G	H	J						
		[CABINET]																		
△	D02MA 006570	MAGNET CONTACTOR	S-N11CX AC100V 1a	MITSUBISHI	KM102				1											
△	D02MA 006610	do	S-N21CX AC100V 2a2b	do	do					1										
△	D43PA 001380	SPARK KILLER	XAB-1201	OKAYA	Z102				1	1										
△	D19FA 001960	PUSH BUTTON	AH165-SLW11AA3	FUJI	SB15				1	1										
		[CABLE]																		
	D71676 50010	EXHAUST UNIT CABLE	CABINET<->EXHAUST UNIT (COVATRON)	YAMAZAKI	W501	1		2												
	D71676 51010	do	do (SHINTO PXIII)	do	do		1													

29

STD	48	510	612
CE	1.5Kw	2.5Kw	4Kw

△		 YAMAZAKI MAZAK CORPORATION	APR'D BY	CHK'D BY	DRWN BY	TITLE
△			99/11/30	99/11/30	99/11/30	EXHAUST UNIT (OPTION)
△			T. Inoue	M Okajima	M Okajima	DRWN NO. 676 001 13521, 0
△	Edition Jul.23.'01 M.Okajima					

This product is subject to all the applicable Japanese Foreign Exchange and Foreign Trade Law.
 本品は『外国為替及び外国貿易法』に該当しますので外国に輸出する場合には同法に基づく許可を必要とします。

01 A B C D E F G H I J K L M N O P
PARTS LIST

△△△△

PA CA	PARTS No.	PARTS NAME & DATA	CATALOGUE TYPE	SUPPLYER	ITEM	QUANTITY														
						A	B	C	D	E	F	G	H	J						
	D70YC 004330	NON CONTACT I/F BOARD	OPU-100	NADEX	A14	1	1													
	D13FA 001350	SELECT SWITCH	AH165-P2B11	FUJI	SA1, 16	1	1	1	1											
	A05GS 003680	SKT. HD. CAP SCR.	M2. 6x5	GOSHO		2														
△	D71676 50052	NON CONTACT CABLE	XT71<->NON CONTACT AMP (MAZAK TYPE)	YAMAZAKI	W505	1														
△	D71676 51051	do	do (WEIDMULLER TYPE)	do	do		1													
△	D71676 50211	YV28 CABLE	XT71<->COOLING JACKET SOL	do	W521		1													
△	D71676 20400	YV5 CABLE	XT71<->STYLUS UP SOL	do	W240			1												
11																				
12																				
13																				
14																				
15																				
16																				
17																				
18																				
19																				
20																				
21																				
22																				
23																				
24																				
25																				
26																				
27																				
28																				

STD	48	510	612	
CE	1.5Kw	2.5Kw	4Kw	

△		 YAMAZAKI MAZAK CORPORATION	APR' D BY	CHK' D BY	DRWN BY	TITLE
△			99/11/30	99/11/30	99/11/30	GAP SENSOR (OPTION)△
△	Edition Aug. 07.'01 M. Okajima		T. Inoue	M Okajima	M Okajima	
△	Edition Aug. 10.'00 M. Okajima					DRWN NO. 676 001 13543, 0
△	Edition Mar. 28.'00 M. Okajima					

This product is subject to all the applicable Japanese Foreign Exchange and Foreign Trade Law.
 本品は『外国為替及び外国貿易法』に該当しますので外国に輸出する場合には同法に基づく許可を必要とします。

01 A B C D E F G H I J K L M N O P
PARTS LIST

02	PA CA	PARTS No.	PARTS NAME & DATA	CATALOGUE TYPE	SUPPLYER	ITEM	QUANTITY													
							A	B	C	D	E	F	G	H	J					
03																				
04	△	D19FA 001960	PUSH BUTTON	AH165-SLW11AA3	FUJI	SB32 HL32	1													
05																				
06																				
07																				
08																				
09																				
10																				
11																				
12																				
13																				
14																				
15																				
16																				
17																				
18																				
19																				
20																				
21																				
22																				
23																				
24																				
25																				
26																				
27																				
28																				

029																				
030																				

STD	48	510	612
CE	1.5Kw	2.5Kw	4Kw

△		 YAMAZAKI MAZAK CORPORATION	APR'D BY	CHK'D BY	DRWN BY	TITLE
△			99/11/30	99/11/30	99/11/30	RETRACE (OPTION)
△			T. Inoue	M Okajima	M Okajima	DRWN NO.
△	Edition Jul.01.'00 M.Okajima					676 001 13561,0

This product is subject to all the applicable Japanese Foreign Exchange and Foreign Trade Law.
 本品は『外国為替及び外国貿易法』に該当しますので外国に輸出する場合には同法に基づく許可を必要とします。

01 A B C D E F G H I J K L M N O P

PARTS LIST

02	PA CA	PARTS No.	PARTS NAME & DATA	CATALOGUE TYPE	SUPPLYER	ITEM	QUANTITY													
							A	B	C	D	E	F	G	H	J					
03																				
04	△	D71676 50151	YV21 CABLE	XT31<->SIDE GAUGE UP SOL	YAMAZAKI	W515	1													
	△	D71676 50161	YV31 CABLE	XT31<->SIDE GAUGE DOWN SOL	do	W516	1													
05																				
06																				
07																				
08																				
09																				
10																				
11																				
12																				
13																				
14																				
15																				
16																				
17																				
18																				
19																				
20																				
21																				
22																				
23																				
24																				
25																				
26																				
27																				
28																				

29																				
30																				

STD	48	510	612
CE	1.5Kw	2.5Kw	4Kw

△		 YAMAZAKI MAZAK CORPORATION	APR'D BY	CHK'D BY	DRWN BY	TITLE
△			99/11/30	99/11/30	99/11/30	LOADER SENSOR (OPTION)
△			T. Inoue	M Okajima	M Okajima	DRWN NO. 676 001 13601, 0
△	Edition Mar. 28. '00 M. Okajima					

This product is subject to all the applicable Japanese Foreign Exchange and Foreign Trade Law.
 本品は『外国為替及び外国貿易法』に該当しますので外国に輸出する場合には同法に基づく許可を必要とします。

01 A B C D E F G H I J K L M N O P
PARTS LIST

02	PA CA	PARTS No.	PARTS NAME & DATA	CATALOGUE TYPE	SUPPLYER	ITEM	QUANTITY													
							A	B	C	D	E	F	G	H	J					
03																				
04	△2	D19FA 001960	PUSH BUTTON	AH165-SLW11AA3	FUJI	SB38 HL38	1													
05	△1	D71676 50351	YV95 CABLE	XT71<->AUX. NOZZLE UP SOL	YAMAZAKI	W535	1													
06	△1	D71676 50361	YV96 CABLE	XT71<->AUX. NOZZLE DOWN SOL	do	W536	1													
06	△1	D71676 50371	YV97 CABLE	XT71<->AUX. NOZZLE TURN SOL	do	W537	1													
07	△1	D71676 50381	YV98 CABLE	XT71<->AUX. NOZZLE RETURN SOL	do	W538	1													
08		D64ND 005080	NIPO SHEEL	NPS-1608	NIPPON FLEX		4													
09																				
10																				
11																				
12																				
13																				
14																				
15																				
16																				
17																				
18																				
19																				
20																				
21																				
22																				
23																				
24																				
25																				
26																				
27																				
28																				
29																				

STD	48	510	612
CE	1.5Kw	2.5Kw	4Kw

△		 YAMAZAKI MAZAK CORPORATION	APR'D BY	CHK'D BY	DRWN BY	TITLE
△			99/11/30	99/11/30	99/11/30	PIERCING ADAPTER (OPTION)
△			T. Inoue	M Okajima	M Okajima	DRWN NO.
△						676 001 13662.0

This product is subject to all the applicable Japanese Foreign Exchange and Foreign Trade Law.
 本品は『外国為替及び外国貿易法』に該当しますので外国に輸出する場合には同法に基づく許可を必要とします。

01 A B C D E F G H I J K L M N O P

PARTS LIST

02	PA CA	PARTS No.	PARTS NAME & DATA	CATALOGUE TYPE	SUPPLYER	ITEM	QUANTITY													
							A	B	C	D	E	F	G	H	J					
03																				
04	△1	D71676 50251	YV40 CABLE	XT71<->SIDE AIR BLOW SOL	YAMAZAKI	W525	1													
	△2	D71676 50262	YV29 CABLE	XT31<->OIL MIST SOL	do	W526	1													
05																				
06																				
07																				
08																				
09																				
10																				
11																				
12																				
13																				
14																				
15																				
16																				
17																				
18																				
19																				
20																				
21																				
22																				
23																				
24																				
25																				
26																				
27																				
28																				

29																				
30																				

STD	48	510	612
CE	1.5Kw	2.5Kw	4Kw

△		 YAMAZAKI MAZAK CORPORATION	APR'D BY	CHK'D BY	DRWN BY	TITLE
△			99/11/30	99/11/30	99/11/30	SIDE BLOW (OPTION)
△			T. Inoue	M Okajima	M Okajima	DRWN NO.
△						676 001 13682, 0

This product is subject to all the applicable Japanese Foreign Exchange and Foreign Trade Law.
 本品は『外国為替及び外国貿易法』に該当しますので外国に輸出する場合には同法に基づく許可を必要とします。

01 A B C D E F G H I J K L M N O P
PARTS LIST

PA CA	PARTS No.	PARTS NAME & DATA	CATALOGUE TYPE	SUPPLYER	ITEM	QUANTITY																
						A	B	C	D	E	F	G	H	J								
	D20ZZ 002580	SIGNAL LIGHT	AGD-100-3-RYG	ASAHI	A112	1																
	D60ZZ 008010	ZL CONNECTOR	ZLP-08V		X1012	1																
	D60ZZ 008140		SZF-41T-0.7			5																
	D60ZZ 008070		ZLS-08V			2																
07																						
08																						
09																						
10																						
11																						
12																						
13																						
14																						
15																						
16																						
17																						
18																						
19																						
20																						
21																						
22																						
23																						
24																						
25																						
26																						
27																						
28																						

STD	48	510	612	
CE	1.5Kw	2.5Kw	4Kw	

△		 YAMAZAKI MAZAK CORPORATION	APR'D BY	CHK'D BY	DRWN BY	TITLE
△			99/11/30	99/11/30	99/11/30	THREE SIGNAL LIGHT (OPTION)
△			T. Inoue	M Okajima	M Okajima	DRWN NO.
△						676 001 13700, 0
△						

This product is subject to all the applicable Japanese Foreign Exchange and Foreign Trade Law.
 本品は『外国為替及び外国貿易法』に該当しますので外国に輸出する場合には同法に基づく許可を必要とします。

01 A B C D E F G H I J K L M N O P
PARTS LIST

PA CA	PARTS No.	PARTS NAME & DATA	CATALOGUE TYPE	SUPPLYER	ITEM	QUANTITY												
						A	B	C	D	E	F	G	H	J				
	D51MA 009660	LEAK DETECTION BREAKER	NV225-CP 3P 150A 500mA TBM AC100V	MITSUBISHI	QF1	1												
△	D51MA 012750	do	NV225-CP 3P 125A 500mA TBM AC100V	do	do	1												
	D51MA 011540	do	NV225-CP 3P 225A 500mA TBM AC100V	do	do		1											
△	D51MA 009650	do	NV225-CP 3P 200A 500mA TBM AC100V	do	do		1											
	D51MA 011110	do	NV400-CP 3P 300A 500mA TBM AC100V	do	do			1										
△	D51MA 012760	do	NV400-CP 3P 250A 500mA TBM AC100V	do	do			1										
	D51MA 009680	LEAK DETECTION BREAKER	NV100-SP 3P 75A 500mA TBM AC100V	MITSUBISHI	QF1				1									
	D51MA 011530	do	NV225-SP 3P 125A 500mA TBM AC100V	do	do					1								
	D51MA 010570	do	NV225-SP 3P 150A 500mA TBM AC100V	do	do						1							

STD	48	510	612	
CE	1.5Kw	2.5Kw	4Kw	

△		 YAMAZAKI MAZAK CORPORATION	APR'D BY	CHK'D BY	DRWN BY	TITLE
△			99/11/30	99/11/30	99/11/30	LEAK DETECTION BREAKER (OPTION)
△			T. Inoue	M Okajima	M Okajima	DRWN NO.
△	Edition Aug. 09. '01 M. Okajima					676 001 13721, 0

This product is subject to all the applicable Japanese Foreign Exchange and Foreign Trade Law.
 本品は『外国為替及び外国貿易法』に該当しますので外国に輸出する場合には同法に基づく許可を必要とします。

01 A B C D E F G H I J K L M N O P
PARTS LIST

△5

PA CA	PARTS No.	PARTS NAME & DATA	CATALOGUE TYPE	SUPPLYER	ITEM	QUANTITY											
						A	B	C	D	E	F						
△1	D19FA 001960	PUSH BUTTON	AH165-SLW11AA3	FUJI	SB8, SB9 HL201 HL202	2	2	2	2	2	2						
	D71676 50690	COVER BOX CABLE	XT31<->COVER BOX	YAMAZAKI	W569	1			1								
	D71677 50690	do		do	do		1			1							
	D71678 50690	do		do	do			1			1						
	D71676 50500	SQ11 CABLE	COVER BOX<-> SLIDE COVER OPEN LS	do	W550	1			1								
	D71677 50500	do		do	do		1			1							
	D71678 50500	do		do	do			1			1						
	D71676 50510	SQ13 CABLE	COVER BOX<-> SLIDE COVER CLOSE 1 LS	do	W551	1			1								
	D71677 50510	do		do	do		1			1							
	D71678 50510	do		do	do			1			1						
△4	D71676 50521	SQ500 CABLE	COVER BOX<-> SLIDE COVER CLOSE 2 LS	do	W552	1											
	D71677 50520	do		do	do		1										
	D71678 50520	do		do	do			1									
△2	D71676 50531	SQ21 CABLE	COVER BOX<-> SLIDE COVER OPEN DEC LS	do	W553	1			1								
△2	D71677 50531	do		do	do		1			1							
	D71678 50530	do		do	do			1			1						
	D71676 50540	SQ22 CABLE	COVER BOX<-> SLIDE COVER CLOSE DEC LS	do	W554	1			1								
	D71677 50540	do		do	do		1			1							
	D71678 50540	do		do	do			1			1						
	D71676 50560	YV9 CABLE	XT31<-> SLIDE COVER OPEN SOL	do	W556	1	1	1	1	1	1						
	D71676 50570	YV10 CABLE	XT31<-> SLIDE COVER CLOSE SOL	do	W557	1	1	1	1	1	1						
	D71676 50580	YV11 CABLE	XT31<-> SLIDE COVER OPEN DEC SOL	do	W558	1	1	1	1	1	1						
	D71676 50590	YV12 CABLE	XT31<-> SLIDE COVER CLOSE DEC SOL	do	W559	1	1	1	1	1	1						
△4	D71676 50681	SQ500 CABLE	COVER BOX<-> CE SLIDE COVER CLOSE LS	do	W568				1								
	D71677 50680	do		do	do					1							
	D71678 50680	do		do	do						1						
△6	D03MA 008390	THERMAL	TH-N12CXKP 0.9A	mitsubishi	FR202			1			1						
△6	D03MA 008640	HOLDER	UN-HZ12CX	do	do			1			1						
△6	D53TD 004610	TERMINAL BLOCK	PTUL-20x6P	TOYOGIKEN	XT202			1			1						
△6	D43PA 001390	SPARK KILLER	3CRE-50500	OKAYA	Z202			1			1						
△6	D71678 90360	M201 CABLE	CABINET<->TABLE FAN	YAMAZAKI	W936			1			1						
△6	D71678 90370	M202 CABLE	do	do	W937			1			1						
△6	D71676 90421	FR202 CABLE	XT2, 202<->FR202, XT202	do	W942			1			1						

△8
△
△6 Edition May. 27. '05 M.Okajima

STD	48	510	612
CE	1.5Kw	2.5Kw	4Kw

△ Edition Jun. 03. '04 M.Okajima	 YAMAZAKI MAZAK CORPORATION	APR' D BY	CHK' D BY	DRWN BY	TITLE
△ Edition Jan. 15. '02 M.Okajima		99/11/30	99/11/30	99/11/30	ENCLOSURE COVER(1) (OPTION)
△ Edition Aug. 07. '01 M.Okajima		T. Inoue	M Okaji ma	M Okaji ma	DRWN NO. 676 001 13806, 0
△ Edition Aug. 25. '00 M.Okajima					
△ Edition Jul. 01. '00 M.Okajima					

This product is subject to all the applicable Japanese Foreign Exchange and Foreign Trade Law.
 本品は『外国為替及び外国貿易法』に該当しますので外国に輸出する場合には同法に基づく許可を必要とします。

01 A B C D E F G H I J K L M N O P
PARTS LIST

02	PA CA	PARTS No.	PARTS NAME & DATA	CATALOGUE TYPE	SUPPLYER	ITEM	QUANTITY							
							G	H	J	K	L	M		
04	△1	D19FA 001960	PUSH BUTTON	AH165-SLW11AA3	FUJI	SB8, SB9 HL201 HL202	2	2	2	2	2	2		
05		D71676 50690	COVER BOX CABLE	XT31<->COVER BOX	YAMAZAKI	W569	1			1				
06		D71677 50690	do		do	do		1			1			
06		D71678 50690	do		do	do			1			1		
07		D71676 50560	YV9 CABLE	XT31<-> SLIDE COVER OPEN SOL	do	W556	1	1	1	1	1	1		
08		D71676 50570	YV10 CABLE	XT31<-> SLIDE COVER CLOSE SOL	do	W557	1	1	1	1	1	1		
09														
10	△2	D71676 50721	SQ507 CABLE	COVER BOX<-> CE PALLET COVER CLOSE LS	do	W572	1							
10	△2	D71677 50721	do		do	do		1						
11		D71678 50720	do		do	do			1					
12	△4	D71676 51720	SQ507 CABLE	COVER BOX<-> CE PALLET COVER CLOSE LS	do	W572				1				
12	△4	D71677 51720	do		do	do					1			
12	△4	D71678 51720	do		do	do						1		
13		D71676 50700	SQ65 CABLE	COVER BOX<-> PALLET COVER OPEN LS	do	W570	1			1				
13	△3	D71677 50701	do		do	do		1			1			
14		D71678 50700	do		do	do			1			1		
14	△2	D71676 50711	SQ66 CABLE	COVER BOX<-> PALLET COVER CLOSE LS	do	W571	1			1				
15	△2	D71677 50711	do		do	do		1			1			
15		D71678 50710	do		do	do			1			1		
16	△2	D71676 50602	SQ55, 56, 501, 502 CABLE	XT31<-> FIXED COVER LS	YAMAZAKI	W560	1							
17	△3	D71677 50603			do	do		1						
17		D71678 50600			do	do			1					
18	△4	D71676 51600	SQ55, 56, 501, 502 CABLE	XT31<-> FIXED COVER LS	do	W560				1				
18	△4	D71677 51600			do	do					1			
18	△4	D71678 51600			do	do						1		
19	△2	D71676 50622	SQ57, 58, 503, 504 CABLE	CABINET<-> FIXED COVER LS	do	W562	1							
20	△3	D71677 50623			do	do		1						
20		D71678 50620			do	do			1					
21	△4	D71676 51620	SQ57, 58, 503, 504 CABLE	CABINET<-> FIXED COVER LS	do	W562				1				
21	△4	D71677 51620			do	do					1			
21	△4	D71678 51620			do	do						1		
22														
23														
24														
25														
26														
27														
28														
29														

STD	48	510	612
CE	1.5Kw	2.5Kw	4Kw

△	Edition Jun.03.'04 M.Okajima	 YAMAZAKI MAZAK CORPORATION	APR'D BY	CHK'D BY	DRWN BY	TITLE
△	Edition Aug.07.'01 M.Okajima		99/11/30	99/11/30	99/11/30	ENCLOSURE COVER(2) (OPTION)
△	Edition Oct.12.'00 M.Okajima		T. Inoue	M Okaji ma	M Okaji ma	DRWN NO.
△	Edition Aug.25.'00 M.Okajima					676 001 13814, 0

This product is subject to all the applicable Japanese Foreign Exchange and Foreign Trade Law.
 本品は『外国為替及び外国貿易法』に該当しますので外国に輸出する場合には同法に基づく許可を必要とします。

01 A B C D E F G H I J K L M N O P
PARTS LIST

PA CA	PARTS No.	PARTS NAME & DATA	CATALOGUE TYPE	SUPPLYER	ITEM	QUANTITY														
						A	B	C	D	E	F	G	H	J						
		[PALLET BOX]																		
	D02MA 006850	MAGNET CONTACTOR	S-N35CX AC100V 2a2b	mitsubishi	KM60	1	1	1	1	1	1									
△	D02MA 006590	do	S-N11CX AC100V 1b	do	KM61	1	1	1	1	1	1									
	D43PA 001380	SPARK KILLER	XAB-1201	OKAYA	Z660, 661	2	2	2	2	2	2									
	D04TC 000100	RELAY	LY2 DC24V	OMRON	KA, V 60, 61, 62 63, 64	13	13	13	13	13	13									
	D04TC 001900	SOCKET	PTF08A-E	do	do	13	13	13	13	13	13									
	D04TC 001170	HOLDER	PYC-A1	do	601, 602 603, 604	13	13	13	13	13	13									
	D34TA 001540	DIODE	S5277G	TOSHIBA	605, 606 607, 608	13	13	13	13	13	13									
	D43PA 001380	SPARK KILLER	XAB-1201	OKAYA	Z61, 62 63, 64 601, 602 603, 604 605, 606 607, 608	12	12	12	12	12	12									
	D04TC 000010	RELAY	G2A-432A DC24V	OMRON																
	D04TC 001890	SOCKET	PYF14A-E	do																
	D04TC 001180	HOLDER	PYC-A2	do																
	D34TA 001540	DIODE	S5277G	TOSHIBA																
	D53TD 004720	TERMINAL BLOCK	PTUL-40x6P	TOYO GIKEN	XT60	1	1	1	1	1	1									
△	D53TD 007780	do	PTUL-10x55P	do	XT61	1	1	1	1	1	1									
	D11TQ 000230	DOOR SWITCH	D2D-2000	OMRON	SQ206	1	1	1	1	1	1									
△	D64ZZ 004980	HOLE PLUG	DP-875	HEICO		3	3	3	3	3	3									
	466019 00071	EARTH BAR	20x120 t5	YAMAZAKI		1	1	1	1	1	1									
	D56YC 001580	EARTH MARK	⊕	do		2	2	2	2	2	2									
		[PALLET O. P. PANEL]																		
	D15IA 003110	EMERGENCY STOP PB	HW1B-V402-TK1890	IZUMI	SB501	1	1	1	1	1	1									
	D19FA 000880	PUSH BUTTON	AH165-TLR11E3	FUJI	SB20	1	1	1	1	1	1									
	D19FA 001720	do	AH165-TGLG11E3	do	SB21	1	1	1	1	1	1									
	D26FA 000600	KEY SELECT SWITCH	AH165-2J2B11C	do	SA5	1	1	1	1	1	1									
	D26FA 000760	do	AR22JR-2A22A	do	SA608	1	1	1	1	1	1									
△	D19FA 001350	SELECT SWITCH	AH165-P2B11	do	SA601	1	1	1	1	1	1									
△	D19FA 001730	PUSH BUTTON	AH165-SLW11E3	do	SB22 602 604, 605 606, 607	6	6	6	6	6	6									
	D21PA 000790	LED	BD-3611R-24	OKAYA	HL22	1	1	1	1	1	1									
	D21PA 000800	do	BD-3612G-24	do	HL21	1	1	1	1	1	1									
	D21PA 000810	do	BD-3613A-24	do	HL20 611, 612	3	3	3	3	3	3									
△	D64ZZ 004940	HOLE PLUG	DP-625	HEICO		1	1	1	1	1	1									
△	D53TD 005000	TERMINAL BLOCK	PTUL-10x10P	TOYO GIKEN	XT66	1	1	1	1	1	1									
		[XT63]																		
	D53TD 004880	TERMINAL BLOCK	PTUL-10x30P	TOYO GIKEN	XT63	1	1	1	1	1	1									
	466019 00071	EARTH BAR	20x120 t5	YAMAZAKI		1	1	1	1	1	1									
	D56YC 001580	EARTH MARK	⊕	do		1	1	1	1	1	1									
△	D53TD 005000	TERMINAL BLOCK	PTUL-10x10P	TOYO GIKEN	XT67	1	1	1												

STD	48	510	612
CE	1.5Kw	2.5Kw	4Kw

△	Edition Aug. 28. '00 M. Okajima	 YAMAZAKI MAZAK CORPORATION	APR' D BY	CHK' D BY	DRWN BY	TITLE
△	Edition Jul. 14. '00 M. Okajima		99/11/30	99/11/30	99/11/30	PALLET CHANGER (1) (OPTION)
△	Edition Apr. 07. '00 M. Okajima		T. Inoue	M Okajima	M Okajima	DRWN NO. 676 001 13904, 0
△	Edition Mar. 29. '00 M. Okajima					

This product is subject to all the applicable Japanese Foreign Exchange and Foreign Trade Law.
 本品は『外国為替及び外国貿易法』に該当しますので外国に輸出する場合には同法に基づく許可を必要とします。

01 A B C D E F G H I J K L M N O P
PARTS LIST

02	PA CA	PARTS No.	PARTS NAME & DATA	CATALOGUE TYPE	SUPPLYER	ITEM	QUANTITY													
							A	B	C	D	E	F	G	H	J					
03			[CABLE]																	
04	△5	D71676 60103	PALLET BRACKET CABLE	INSIDE BRACKET	YAMAZAKI	W610	1	1	1	1	1	1								
	△2	D71676 60111	SVP1 6CN CABLE	BRACKET(X661)<->SVP1(X6CN1)	do	W611	1	1	1	1	1	1								
05	△2	D71676 60121	SVP2 6CN CABLE	BRACKET(X662)<->SVP2(X6CN2)	do	W612	1	1	1	1	1	1								
	△2	D71676 60131	SVP3 6CN CABLE	BRACKET(X663)<->SVP3(X6CN3)	do	W613	1	1	1	1	1	1								
06	△2	D71676 60141	SVP4 6CN CABLE	BRACKET(X664)<->SVP4(X6CN4)	do	W614	1	1	1	1	1	1								
	△2	D71676 60151	SVP5 6CN CABLE	BRACKET(X665)<->SVP5(X6CN5)	do	W615	1	1	1	1	1	1								
07	△1	D71676 60161	SVP 1CN CABLE	XT61, RY<->SVP1, 2, 3, 4, 5	do	W616	1	1	1	1	1	1								
	△1	D71676 60171	SVP POWER CABLE	KM60, 61, EARTH<->SVP1, 2, 3, 4, 5	do	W617	1	1	1	1	1	1								
08		D71676 60180	SVP CONTROL CABLE	XT60<->SVP1, 2, 3, 4, 5	do	W618	1	1	1	1	1	1								
09	△3	D71676 60011	PALLET BOX POWER CABLE	CABINET<->P. BOX	YAMAZAKI	W601	1			1										
	△3	D71677 60011	do	do	do	do		1			1									
10		D71678 60010	do	do	do	do			1				1							
		D71676 60020	PALLET BOX DC CABLE	CABINET<->P. BOX (X124)	do	W602	1			1										
11		D71677 60020	do	do	do	do		1			1									
		D71678 60020	do	do	do	do			1				1							
12		D71676 60030	PALLET BOX DC CABLE	CABINET<->P. BOX (X161)	do	W603	1			1										
		D71677 60030	do	do	do	do		1			1									
13		D71678 60030	do	do	do	do			1				1							
		D71676 60040	PALLET BOX DC CABLE	CABINET<->P. BOX (125)	do	W604	1			1										
14		D71677 60040	do	do	do	do		1			1									
		D71678 60040	do	do	do	do			1				1							
15	△3	D71676 60611	XT63 DC CABLE	P. BOX<->XT63	YAMAZAKI	W661	1			1										
16	△3	D71677 60611	do	do	do	do		1			1									
		D71678 60610	do	do	do	do			1				1							
17	△3	D71676 60621	XT63 AC CABLE	P. BOX<->XT63	do	W662	1			1										
	△3	D71677 60621	do	do	do	do		1			1									
18		D71678 60620	do	do	do	do			1				1							
19	△3	D71676 60651	PALLET O. P. CABLE	P. BOX<->PALLET O. P. PANEL	do	W665	1			1										
	△3	D71677 60651	do	do	do	do		1			1									
		D71678 60650	do	do	do	do			1				1							
20	△2	D71676 60661	PALLET O. P. CABLE	INSIDE PALLET O. P. PANEL	do	W666	1	1	1	1	1	1	1							
21	△2	D71676 60710	PALLET FT CABLE	P. BOX<->PALLET FT	YAMAZAKI	W671	1	1	1											
	△2	D71676 63710	do	do	do	do				1	1	1								
22	△2	D71676 60720	SQ603 CABLE	P. BOX<->PALLET ENABLE PRS	do	W672	0	0	0	0	0	0								
	△2	D71676 60730	SQ73, 612 CABLE	P. BOX<->LIGHT BARRIER SENSOR	do	W673	1	1	1											
23	△4	D71676 60952	SQ651 CABLE	XT66<->CE LIGHT BARRIER	do	W695				1	1	1								
	△4	D71676 60962	SQ652 CABLE	P. BOX<->CE LIGHT BARRIER	do	W696				1	1	1								
24	△3	D71676 60811	YV601 CABLE	XT63<->WC 1 OPEN SOL	do	W681	1	1	1	1	1	1								
	△3	D71676 60821	YV602 CABLE	XT63<->WC 1 COLSE SOL	do	W682	1	1	1	1	1	1								
25	△3	D71676 60831	YV603 CABLE	XT63<->WC 2 OPEN SOL	do	W683	1	1	1	1	1	1								
	△3	D71676 60841	YV604 CABLE	XT63<->WC 2 CLOSE SOL	do	W684	1	1	1	1	1	1								
26	△3	D71676 60852	YV605 CABLE	XT63<->P CLAMP 1 CLOSE SOL	do	W685	1	1	1	1	1	1								
	△3	D71676 60862	YV606 CABLE	XT63<->P CLAMP 1 OPEN SOL	do	W686	1	1	1	1	1	1								
27	△3	D71676 60872	YV607 CABLE	XT63<->P CLAMP 1 CLOSE SOL	do	W687	1	1	1	1	1	1								
	△3	D71676 60882	YV608 CABLE	XT63<->P CLAMP 2 OPEN SOL	do	W688	1	1	1	1	1	1								
28	△2	D71676 60910	SQ601 CABLE	XT63<->PALLET ON 1 LS	do	W691	1	1	1	1	1	1								
	△2	D71676 60920	SQ602 CABLE	XT63<->PALLET ON 2 LS	do	W692	1	1	1	1	1	1								

STD	48	510	612
CE	1.5Kw	2.5Kw	4Kw

△ Edition Oct. 12.'00 M.Okajima	 YAMAZAKI MAZAK CORPORATION	APR'D BY	CHK'D BY	DRWN BY	TITLE
△ Edition Aug. 28.'00 M.Okajima		99/11/30	99/11/30	99/11/30	PALLET CHANGER (2) (OPTION)
△ Edition Aug. 13.'00 M.Okajima		T. Inoue	M Okajima	M Okajima	DRWN NO. 676 001 13915, 0
△ Edition May. 30.'00 M.Okajima					
△ Edition Mar. 29.'00 M.Okajima					

This product is subject to all the applicable Japanese Foreign Exchange and Foreign Trade Law.
 本品は『外国為替及び外国貿易法』に該当しますので外国に輸出する場合には同法に基づく許可を必要とします。

01 A B C D E F G H I J K L M N O P
PARTS LIST

02	PA CA	PARTS No.	PARTS NAME & DATA	CATALOGUE TYPE	SUPPLYER	ITEM	QUANTITY												
							A	B	C	D	E	F	G	H	J				
04	△	D71676 60512	U/D1 ENCODER CABLE	P. BOX<->U/D MOTOR 1	YAMAZAKI	W651	1			1									
	△	D71677 60512	do	do	do	do		1			1								
05		D71678 60510	do	do	do	do			1			1							
	△	D71676 60523	U/D1 MOTOR CABLE	do	do	W652	1			1									
06	△	D71677 60524	do	do	do	do		1			1								
	△	D71678 60520	do	do	do	do			1			1							
07	△	D71676 60532	U/D2 ENCODER CABLE	P. BOX<->U/D MOTOR 2	do	W653	1			1									
	△	D71677 60532	do	do	do	do		1			1								
08		D71678 60530	do	do	do	do			1			1							
	△	D71676 60543	U/D2 MOTOR CABLE	do	do	W654	1			1									
09	△	D71677 60544	do	do	do	do		1			1								
		D71678 60540	do	do	do	do				1			1						
10	△	D71676 60552	U/D3 ENCODER CABLE	P. BOX<->U/D MOTOR 3	do	W655	1			1									
	△	D71677 60553	do	do	do	do		1			1								
11		D71678 60550	do	do	do	do			1			1							
	△	D71676 60563	U/D3 MOTOR CABLE	do	do	W656	1			1									
12	△	D71677 60564	do	do	do	do		1			1								
		D71678 60560	do	do	do	do				1			1						
13	△	D71676 60572	U/D4 ENCODER CABLE	P. BOX<->U/D MOTOR 4	do	W657	1			1									
	△	D71677 60572	do	do	do	do		1			1								
14		D71678 60570	do	do	do	do				1			1						
	△	D71676 60583	U/D4 MOTOR CABLE	do	do	W658	1			1									
15	△	D71677 60584	do	do	do	do		1			1								
		D71678 60580	do	do	do	do				1			1						
16	△	D71676 60593	F/R ENCODER CABLE	P. BOX<->F/R MOTOR	do	W659	1			1									
	△	D71677 60593	do	do	do	do		1			1								
17		D71678 60590	do	do	do	do				1			1						
	△	D71676 60602	F/R MOTOR CABLE	do	do	W660	1			1									
18	△	D71677 60603	do	do	do	do		1			1								
		D71678 60600	do	do	do	do				1			1						
19	△	D71676 60990	PALLET ENCODER JUMPER	PALLET SERVO ENCODER	do	W699	1	1	1	1	1	1							

STD	48	510	612
CE	1.5Kw	2.5Kw	4Kw

△	Edition Aug. 28.'00 M.Okajima	 YAMAZAKI MAZAK CORPORATION	APR'D BY	CHK'D BY	DRWN BY	TITLE
△	Edition Aug. 13.'00 M.Okajima		99/11/30	99/11/30	99/11/30	PALLET CHANGER(3) (OPTION)
△	Edition Jul. 17.'00 M.Okajima		T. Inoue	M Okajima	M Okajima	DRWN NO.
△	Edition May. 26.'00 M.Okajima					676 001 13924, 0

This product is subject to all the applicable Japanese Foreign Exchange and Foreign Trade Law.
 本品は『外国為替及び外国貿易法』に該当しますので外国に輸出する場合には同法に基づく許可を必要とします。

