

Operation Manual

Circulation-Type Liquid Cooler (with built-in tank)

Orion Digi Eco Chiller

RKED 9000A-V



CAUTION

This equipment is for industrial use only. Please take all necessary precautions during installation and handling.

Read operating manual thoroughly before operating this equipment.

Be sure to retain the operating manual for future reference.

The product warranty is printed at the end of this manual.

Be sure to keep it in a safe place.

This manual is comprised of two sections.



Operating Instructions..... Pages 1 to 66

Installation..... Pages 67 to 83

Thank you for your purchase.

Thank you for purchasing this Orion product. To ensure safe and efficient use, please install and operate this product in accordance with the instructions provided in this manual.

Safety Precautions

Before operating this product, be sure to read through the “ Essential Safety Precautions ” presented in this manual. Failure to observe precautions may result in injury or property damage. Essential safety precautions are categorized as  **WARNINGS** or  **CAUTIONS**. The meaning of each category is as follows.



WARNINGS

Failure to observe the instructions contained in a **WARNING** may result in death or severe injury.







CAUTIONS

Failure to observe the instructions contained in a **CAUTION** may result in injury or physical damage.

Failure to observe **WARNINGS** and **CAUTIONS** can have severe consequences! Please read through this information carefully and handle this product accordingly.



- After reading through this manual, store it near this product so that the operator can refer to it as necessary.
- If you transfer this product to another user, be sure to include this manual together with the product. Place the manual at a prominent location on the product so that the new user is sure to notice it.

Safety Symbols

	<p>The  symbol alerts you to actions you must take or precautions you must observe. The drawing within the triangle indicates the action or precaution. (The indication at left means that you should be careful of catching your hand in the fans.)</p>
	<p>The  symbol indicates a prohibited action or operation. The drawing in (or near) the circle indicates the content of the action. (The indication at left means that you must not disassemble the product.)</p>
	<p>The  symbol indicates an action that you are required to carry out. Again, the drawing in the circle illustrates the action. (The indication at left means that you must connect the product to ground.)</p>
	<p>The  symbol indicates important information. Although important, this information does not constitute a "warning" or "caution."</p>

Operation Instructions

Contents





 Essential Safety Precautions	2
 Unit Warning Label Locations	4
Ensuring The Unit Performs To Specifications	5
Main Parts of the Unit.....	7
Operating Procedures	9
Safety Devices	20
Monitoring.....	21
Parameters.....	22
Communications Functions	30
Communications Specifications	31
Inspection and Maintenance.....	41
Water Quality Control.....	45
Diagnosing and Troubleshooting Unit Failure or Abnormalities	47
Storage (Incl. long periods of disuse and freezing winter periods).....	62
Expendable Parts	63
Main Component Maintenance Cycles	63
Disposal	64
After-sale Services	64
Options.....	65

Essential Safety Precautions

Usage Precautions (WARNINGS)

WARNINGS

Failure to observe the instructions contained in a WARNING may result in death or severe injury.





	<p>Do not modify this equipment Modifying this unit will void the product warranty.</p> <p>All disassembly or repairs must be performed by your dealer or other qualified persons. Improper disassembly or repair work can lead to abnormal operation, which in turn may lead to personal injury, electric shock, or fire.</p>
	<p>Do not operate switches with wet or damp hands. Also, do not allow electrical components to get wet. Failure to follow this warning can lead to electric shock.</p> <p>Do not touch the inverter directly with fingers. The inverter should not be touched directly with fingers as it will be very hot during operation and for some time after the power is removed. Contact with this surface can cause burns.</p>
	<p>Do not operate with the cabinet open. Touching components inside the unit may lead to injury or electric shock.</p> <p>Do not use water directly on the unit or in the unit component area. Do not wash the unit with water. Failure to follow this warning may lead to electric shock or fire.</p> <p>Do not damage or modify the power cord. Placing heavy objects on the cord, exposing it to heat, pulling, or pinching it can result in damage to the cord and possibly lead to electric shock or fire.</p>
	<p>Take measures against refrigerant leaks. If the unit is to be installed in a machine room, measures should be taken to ensure that even if there is a refrigerant leak, refrigerant concentrations won't become critically high. If by some chance there is a refrigerant leak and concentrations become critically high, an accident due to lack of oxygen could result.</p> <p>If abnormal operation is observed, stop operation of the unit and consult with your dealer or a qualified repair person. Continued operation when the unit is performing abnormally can lead to electric shock or fire.</p> <p>If the earth leakage breaker is tripping, please seek the advice of your dealer or a qualified repair person. Operation by continued power recovery can lead to electric shock or fire.</p> <p>When moving the unit, please consult with your dealer or other qualified professionals. Improper installation can lead to water leakage, electric shock, or fire. Always drain the water tank completely before moving or transporting the unit. If water is remaining in the tank while the unit is moved, damage could result from movement of the water tank, etc. Also, if the water freezes, it could result in damage to the pump, valves, or other components. If the unit can be expected to get shocked or damaged while moving, package the unit in order to protect it from such damage.</p> <p>Cut off power source before performing cleaning, maintenance, or inspections. Failure to do so can lead to electric shock, injury, burns, etc. Components inside the inverter will maintain a high-voltage for some time after the power is cut off. Therefore, wait at least 10 minutes after cutting off power before performing any inspection. Touching the inverter soon after power to it has been cut off can result in burns.</p>

Essential Safety Precautions

Usage Precautions (WARNINGS) / (CAUTIONS)

CAUTIONS

Failure to observe the instructions contained in a CAUTION may result in injury or physical damage.

	<p>Only use on designated fluids. Fluid suitable to be cooled (chilled water) is either clean water {according to The Japan Refrigeration and Air Conditioning Industry Association's water quality standard (see page 5 for details)} or a 30 to 40% solution of low concentration industrial-use ethylene glycol in water. Alternatively, if RO treated (deionized) water is to be used, it should have an electrical conductivity of at least 1μS/cm. Cooling non-approved fluids can result in equipment damage, leaking, and possible electric shock or electrical shorts. (Excluding special specifications)</p> <p>Do not operate the unit when the chilled water is blocked. Operating with the cooling water circuit blocked will result in pump damage and cooling water leakage.</p> <p>Do not climb on nor place things on the unit. Doing so can lead to injuries from the unit tipping over or may cause water leakage resulting in an electric short.</p> <p>Do not use combustible sprays near the unit. Also, do not place combustible items near the unit. A spark from a switch or other operations could ignite combustibles, causing a fire.</p> <p>Do not use fuses over the rated amperage. Using metal objects instead of fuses can lead to unit breakdown or fire.</p> <p>Do not use chilled water as a source of drinking water or as a supply of hot water. Drinking the cooling water can lead to adverse effects.</p> <p>Do not operate in places that are very dusty or have corrosive atmospheres. Doing so may cause damage to the unit.</p>
	<p>When cleaning the condenser, do not touch the fins with bare hands. Doing so can lead to injury.</p> <p>Do not touch internal components during operation or just after the power has been cut off. Areas around the compressor will be very hot and could cause burns.</p>
	<p>Do not stick fingers or other objects into the air intake or outlet vents. An internal fan is running at high speed and contacting it could lead to injury.</p>
	<p>Wear protective gloves when opening the cabinet. Sheet metal edges are sharp and could cause injury.</p> <p>Regularly test the earth-leakage breaker to confirm it is working properly. Operating with a faulty earth leakage breaker can result in an electric shock if the breaker fails to activate during electrical trouble.</p> <p>When transferring this equipment, be sure to also include this operating manual. When either transferring or loaning out this equipment, put this operating manual in a bag and tape it to the unit in a clearly visible place so that the new user can refer to it to ensure safe and proper operation.</p> <p>Be sure to follow local regulations when disposing of diluted ethylene glycol solutions. Please remember that illegal disposal not only breaks the law, but can also have adverse effects on the environment and people's health.</p> <p>Contact your dealer for installation of items purchased separately. Failure to follow this warning can lead to injury or electric shock.</p>

Essential Safety Precautions

Unit Warning Label Locations

Unit Warning Label Locations

The warning labels shown below, which are affixed on the front side of this product, display particular important warnings that are carefully selected from significant ones. Be sure to read them before starting its operation. If the labels become worn or damaged, contact local dealer in your area for a replacement label if any of them is damaged in any way.

(Affixed on back)



⚠ WARNING

Cautions not to be caught



When the snow accumulation preventive operation is being turned "ON", the fan will operate intermittently even while the operation of the equipment itself is in stoppage.

Therefore, when removing the cabinet for inspection or repair purposes, be sure to turn off the base power supply.

If you would be caught by the rotary structures like those of the fan, you may suffer a serious injury.

4RB92003010

Be sure to read the instruction manual before starting the operation of the equipment.

⚠ WARNING

Caution against electrification

Since the voltage of this equipment is on a dangerous level, you may suffer electrification accidents or burns resulting possibly in death.

⚠ CAUTION

Cautions not to be caught

If you would be caught by the rotary structures like those of the fan, you may suffer cuts or other injuries. Therefore, do not insert your hand, fingers or a bar into the rotary structure. Be sure to turn off the base power supply when conducting inspections or cleaning.

Be sure to read the following explanations and precautions before starting the operation of the equipment.

1. Installation and test operation

- (1) Never use this equipment under an environment like that of a corrosive gas.
- (2) Use a circuit breaker and wiring cables of the specified capacity and be sure to make effective grounding.
- (3) When wiring the power cable, insert the power cable through the power cable hole positioned in the lower RH side of this equipment so lead to the inside of the distribution panel paying attention not to touch the internal motor and refrigerant piping.

2. Operation

(1) Keep the following table of allowable liquid temperature range and storage allowable ambient temperature range.

	Allowable liquid temperature range	Allowable cooling water temperature range	Storage/ Allowable ambient temperature range
Air-cooled	5 to 35 deg. C	-	-5 to 43 deg. C
Water-cooled	5 to 35 deg. C	5 to 31 deg. C	2 to 43 deg. C

- (2) Use this equipment with the pump discharge pressure within the range being described in the instruction manual. If you use this equipment with the pump discharge pressure other than the specified range, malfunctioning like water leakage, freezing of the chiller may occur.
- (3) Maintain the power supply voltage within $\pm 10\%$ of the rated supply voltage.
- (4) The types of fluids which can be chilled by use of this equipment are city water and industrial purpose low density water solution of ethylene glycol. If you chill any other fluid other than these specified types of fluids, the feeding pump may break causing water leakage.
- (5) In case of stopping the operation during the cold-weather periods, carry out the freeze-prevention operation of cooling circuit following the instruction manual. As for the cooling water circuit of water-cooled chiller, open the freeze-prevention valve. If it freezes up, the cooler and the condenser may be damaged.

3. Daily inspections and countermeasures to take when abnormalities occur

- (1) Clean the filter for the condenser periodically. (In case of the air cooling operation)
- (2) To maintain the water being used in the water circuit in clean state always, inspect the water circuit at least once in a month to replace the water circuit water when soiled.
- (3) Be careful not to cause freezing failure during cold seasons and when the equipment is not being used for a long period of time, drain water from the inside of the water tank and from the water circuit following the instructions given in the instruction manual.

For more details, refer to the instruction manual.

32892004312

Ensuring The Unit Performs To Specifications

CAUTION

1. This product is designed to operate with fresh water (compliant with the water standards below) or with a low concentration industrial-use ethylene-glycol water solution that has a concentration of 30 to 40%. If you are using pure water, use water with an electrical conductivity of 1 μ S/cm or higher.
Input of a different type of liquid may damage the product and may lead to liquid leakage, electric leakage, and electric shock.

Water quality standard

Standard item	pH [25]	Electrical conductivity [25] μ S/cm	Chloride ion (mgCl ⁻ /L)	Sulfuric acid ion (mgSO ₄ ²⁻ /L)	The amount of acid consumption (pH4.8) (mgCaCO ₃ /L)	Total hardness (mgCaCO ₃ /L)	Calcium hardness (mgCaCO ₃ /L)	Ion-like silica (mgSiO ₂ /L)
Circulation water	6.8 to 8.0	400 or less	50 or less	50 or less	50 or less	70 or less	50 or less	30 or less

Reference item	Iron (mgFe/L)	Copper (mgCu/L)	Sulfide ion (mgS ₂ ⁻ /L)	Ammonium ion (mgNH ₄ ⁺ /L)	Remains chlorine (mgCl/L)	Isolation carbonic acid (mgCO ₂ /L)
Circulation water	1.0 or less	1.0 or less	It is not detected	1.0 or less	0.3 or less	4.0 or less

2. If you are using pure water, use water with an electrical conductivity of 1 μ S/cm or higher (lower in purity). When the value of electrical conductivity is small(purity is high),the evaporator or the pressure pump to malfunction or cause fixation of the pressure pump's mechanical seals . In addition, note that this product is not built to specifications for preventing a metallic ion flow-out from the product main body's junctions even if it is used within the allowable operating range. There is, however, no problem in terms of the mechanical strength of the product.
3. Be sure that operating conditions remain within the specified range while product is running. Operation outside of specified limits may result in product failure.

Temperature range ()	5 to 35
Ambient temperature range ()	- 5 to 43
Power source (V·Hz)	Three-phase200 \pm 10% · 50 / 60、 Three-phase220 \pm 10% · 60 (Max. phase unbalance: 3%)
Allowable pressure (MPa) 50/60Hz	Max 0.50

4. The use of aluminum on surfaces that contact Cold Water within the water circuit is strictly prohibited. Parts containing copper or copper-base alloys are used in the internal water circuit of this product. If piping outside the product contains aluminum, the aluminum may contaminate and cause corrosion from copper ions and may lead to water leakage of mechanical seals and/or clogging of the evaporator.

IMPORTANT

The flow circuit for pumped water must never be fully closed during operation (the Cold-Water inlet / outlet and the bypass valve must be open). (Control operation within the green range on the water pressure gauge.) Operation with the water circuit fully closed may cause the evaporator to freeze up or break, the pump to fail, or the hose to drop out.

5. In the case of using brine as anti-freeze measure, we recommend industrial ethylene-glycol water solution that has a concentration of 30 to 40% or lower in order to ensure its cooling capacity. If it corresponds to any of the following conditions of use, however, we recommend carrying out the Freeze-Preventive Operation that makes the pump run alone automatically according to water temperature, because the water solution can go rotten.
 - (1) Installing outside.
 - (2) Water temperature doesn't go down under 20 , even if the product is being stopped.
 - (3) Water hasn't been replaced for more than 3 motnhs.
6. Excessive repetition of the on/off switch operations may cause failure. Be sure to pause for at least 3 minutes between such operations. Operating the switch within 3 minutes after the last operation issues an alarm (**CS**).

Ensuring The Unit Performs To Specifications

7. Be sure to supply water to the water tank and check the water level before starting the operation. An attempt to operate with a water level below "E" on the level gauge will fail, causing an alarm (**EOE**) to be displayed.
8. Control the water pressure at the water inlet at 0.50 MPa or less. A higher pressure may cause water termination or leakage problems.
9. Be sure to keep the water clean by conducting monthly inspection and replacing water if needed. (See "Check the water circuit" on page 43.)
10. Clean the condenser filter monthly. (See "Cleaning the filters" on page 42.)



WARNING

Always cut off the main power before starting maintenance, cleaning, or inspection. Leaving the power supply connected while work is in progress may result in electric shock or in injury from the fan.

11. Ambient temperature should be between -5 and 43 while this product is in use. Running this device at temperatures below -5 may cause the compressor to fail. Ambient temperatures above 43 may impede heat release from the condenser, resulting in safety-device activation and product shutdown. Continuing to run the product while operation is ambient temperatures above 43 may result in malfunction. If you need to install the product in an area where temperatures may exceed 43, you must set up ductwork to supply outside air directly to the air intake on the cabinet, or else construct an outdoor exhaust port to carry warm air outside the building. (See "Duct Design Procedure" on page 78.) In such case, please contact local dealer in your area or service specialists qualified by Orion Machinery.
12. If the product is shut down by tripping of a safety device, please contact local dealer in your area.
13. The water level in the tank may drop quickly the first time you operate the product, or if piping is very long. In such cases you should stop the product, add water to the tank, and then restart.
14. If you need to remove the cabinet plates, please proceed according to the instructions provided herein.
15. When leaving the product out of operation for extended periods, drain the water tank and the entire water circuit.
16. Apply freeze-prevention measures on the external piping. In this procedure, make sure that the cabinet right middle plate can still be removed even after racking and that the bypass valve and the water pressure gauge can be operated and checked.



WARNING

Never operate the product while the cabinet is open. Touching the inside of the product while it is running may result in injury or electric shock.

IMPORTANT

In case of using the product for a first time or after a long time, the air may be contained into the water piping even the water tank is full. Operating the product under such condition may prevent the Cold Water from circulating, which may cause the evaporator to freeze or damaged, or the pressure pump to be damaged.

In this case, first perform pump-only operation to adequately circulate Cold Water through the piping in order to discharge air.

See "Discharging air from the piping" on page 11.

Main Parts of the Unit

External

External

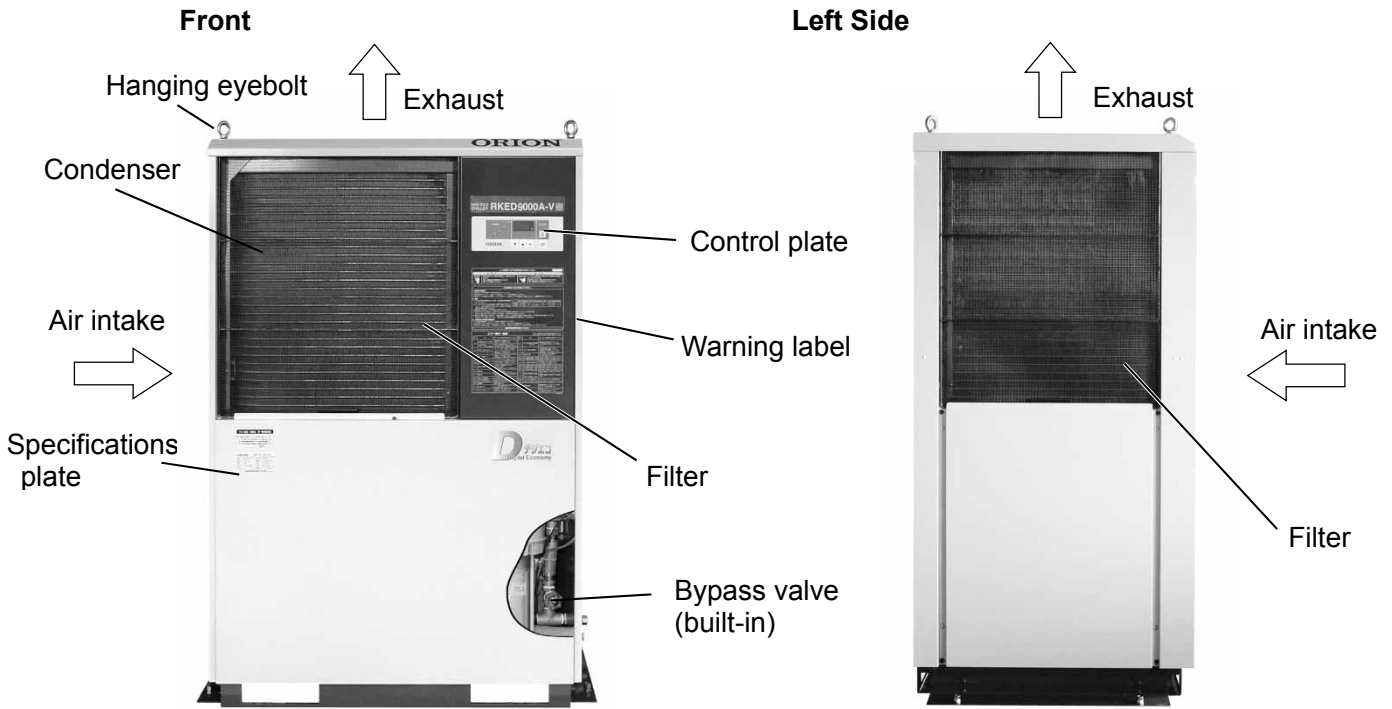

(⇨ : Arrows indicate direction of air flow.)

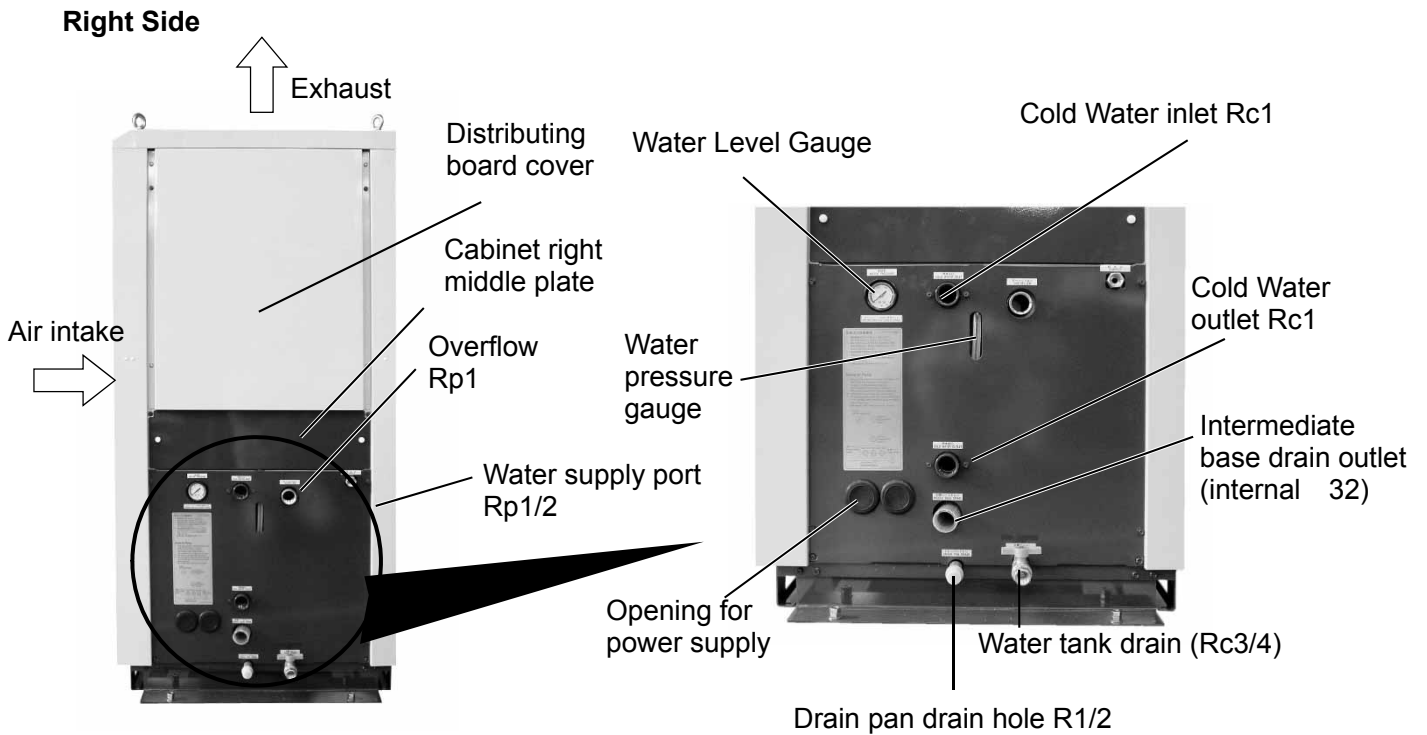

Main Parts of the Unit

Control Plate and Functions

Control Plate and Functions

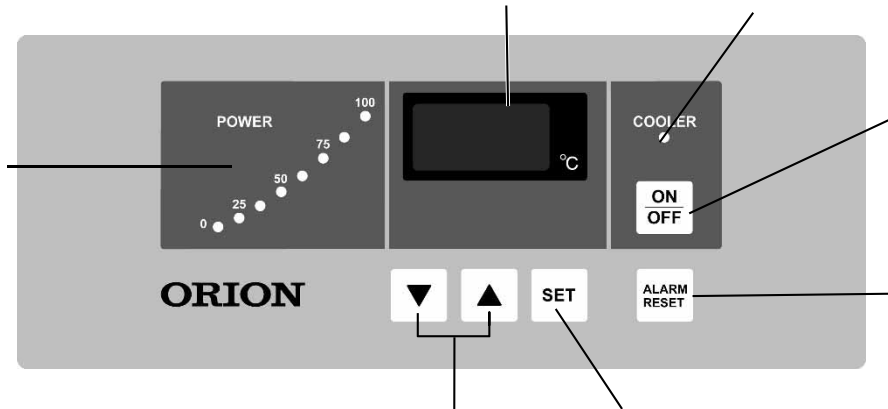

Digital Display		Water temperature (Usual display)
		Error/alarm display (Blinking)
		Blinking of the decimal point: Once per second, when set to the Freeze-Preventive Operation mode. 4 times per second, when set to the Warm-up operation mode
Operation Lamp	Lighted : Product is running. Blinking : Pump only is running. Dark : Product is off.	
ON/OFF Switch		Press this switch to toggle the product ON or OFF.
RESET Switch		Press to clear an error/alarm condition.
SET Switch		Press briefly..... To view the current water-temperature setting. Hold down for 2 seconds..... When you need to change the setting. The current temperature setting blinks on the screen when this switch is pressed. Hold down for 7 seconds or longer..... to display the operational data. (For details, see explanation on page 21.)
Temperature Adjustment Switches Increase the setting. Reduce the setting.	
Compressor Operation Output Display	Displays capacity utilization (%) by lighting a relevant lamp.	

For explanation about the decimal point blinking on the digital display, see the descriptions on the F10 and F11 parameters under "Parameter Types and Functions" on page 23.

Operating Procedures

Running for the first time, or after being stored.



WARNING

Never operate switches with wet hands, and never touch electrical components. Improper handling may result in electric shock.



WARNING

Never operate the product while the cabinet is open. Touching the inside of the product may result in injury or electric shock.

Do not use water to clean this product, and do not allow water to spray or spill onto or in the vicinity of this product. Water contact may result in fire or electric shock.



WARNING

If the product behaves abnormally, switch it off and then cut the power. Then please contact local dealer in your area or service specialists qualified by Orion Machinery. Continuing to run the product while operation is abnormal may result in fire or electric shock.

If Starting Up For the First Time, or After Prolonged Period of Non-Use

Please note the following points before starting the product for the first time, or when restarting it after a long period of non-usage.

1. According to the preparatory instructions, be sure to supply water and check the water level gauge.
2. Check that piping is not leaking.
3. This product operates on 3-phase power supply. If power phase are inverted, error code "E 10" will appear on the display when you start up the power supply. If this occurs, please contact local dealer in your area or service specialists qualified by Orion Machinery for assistance.
4. If you use the main connector, make sure to plug the main connector into the socket before turning ON the earth leakage breaker. If the main connector is plugged into the socket after turned ON the earth leakage breaker, it may display the phase interruption alarm "E09".

IMPORTANT

Air may remain in the water piping even the water tank is filled with water in such cases when the product is used for the first time, the product is restarted after long-term shutdown, or the water is replaced. Running the product with air remained in the water piping may freeze and damage the evaporator.

In this case, first perform pump-only operation to adequately circulate Cold Water through the piping in order to discharge air.

See "Discharging air from the piping" on page 11.

Operating Procedures

Preparing for Operation

Preparing for Operation

Checking the Water Level.

1. Check the level gauge.

Be sure that the water level is between the “E” and “F” marks. If the water level is below “E”, add water as necessary.

Note that a water level higher than “F” may indicate that the tank is overflowing. (The overflow outlet may be closed.)

Operating the product while the level is below “E” may allow air to enter the water-flow circuit, resulting in a loss of normal cooling operation.

The product and pump should be RUN and OFF when the gauge is checked.

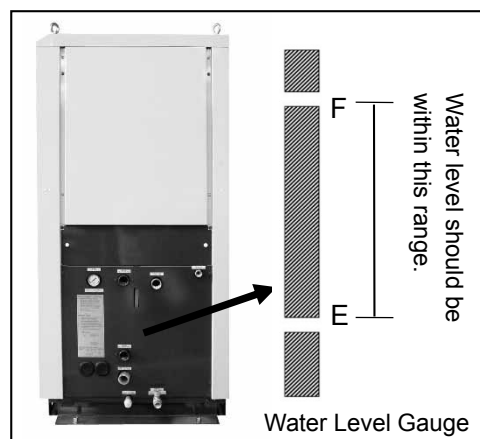

Supplying Water

1. If automatic supply system is installed

- 1) Open the valve to the water-supply port.

Water supply stops automatically when the tank becomes full, and resume automatically when the tank level becomes low.

2. If manual supply (automatic system not installed)

- 1) Remove the cabinet right middle plate (2 screws).
- 2) Remove the tank's water-supply lid.
- 3) Add water directly to the tank using a hose, etc.

If you are using the product for the first time, or if the product has been off for a prolonged period, use pump-only operation (see explanation on page 14) to circulate the water through the system. Then check the level gauge and add water as necessary.

Operating Procedures

Preparation

Discharging air from the Cold Water piping

Air may be present in the piping before the initial start-up of this product, if it has been out of use for an extended period, or after replacing water in the water tank even if the tank is full.

If this problem occurs, conduct a test run on the pressure pump before start-up according to the steps below:

1. Fully open the bypass valve.
2. Removing the cabinet front plate (See page 49).
3. Confirm that the water level in the water tank is in the range from "E" to "F" on the level gauge.
(See "Checking the Water Level" on page 10.)
4. Turn on the main power.
5. Press the ON/OFF switch while holding down the upper arrow Temperature Switch () to operate the pressure pump alone. (See "Pump-Only Operation" on page 14.)
6. As water in the tank circulates through the system while discharging air, the water pressure gauge reading increases and the pressure stabilizes.
7. After the pressure stabilizes, use the bypass valve to establish a desired pressure for operation.
(See "Adjusting the water feeding pressure" on page 12.)

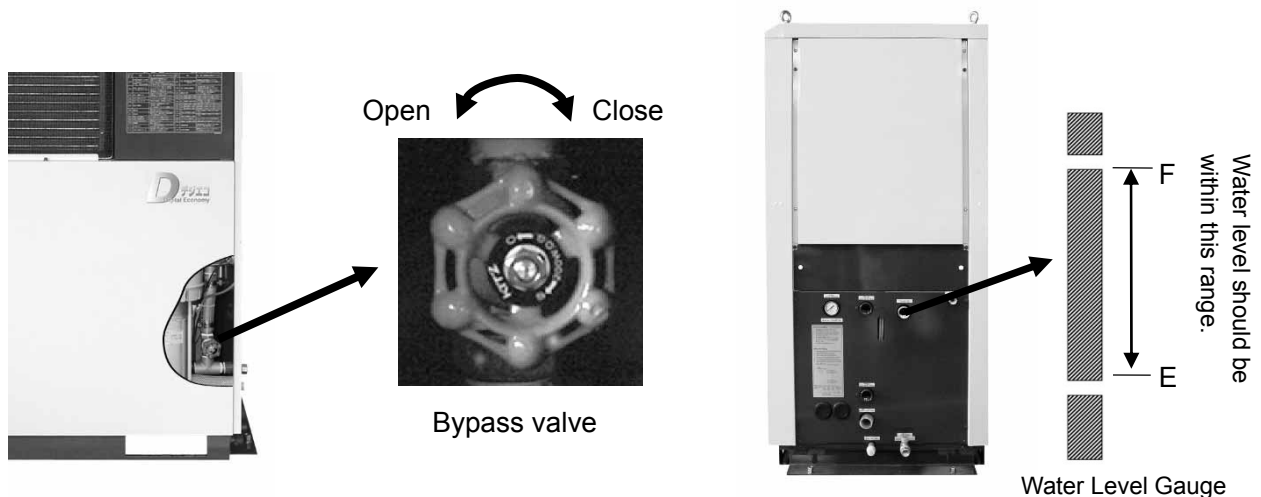

Operating Procedures

Preparation

Adjusting the water feeding pressure (flow rate)

When it becomes necessary to adjust the feeding pressure, follow the procedures outlined below.

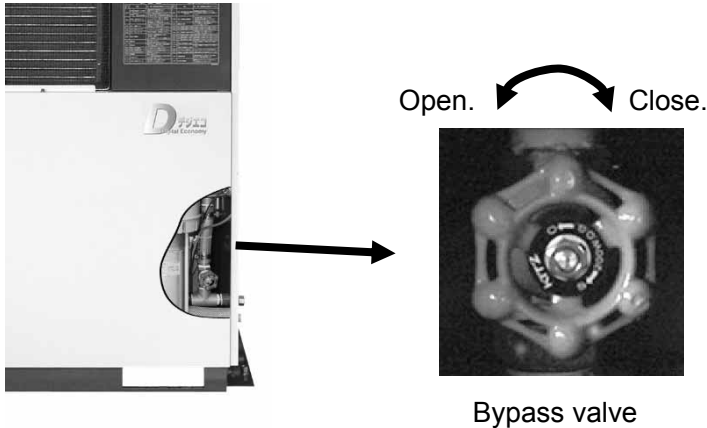
Adjusting method	Bypass valves being incorporated inside the product
Adjusting valve	 <p style="text-align: center;">Bypass valve</p>
To bring up the water feeding pressure (flow rate)	<p style="text-align: center;">Close the bypass valve.</p> <p style="text-align: center;">↓</p> <p style="text-align: center;">The water pressure gauge reading will rise and the water feeding pressure (flow rate) will also rise.</p>
To lower the water feeding pressure (flow rate)	<p style="text-align: center;">Open the bypass valve.</p> <p style="text-align: center;">↓</p> <p style="text-align: center;">The water pressure gauge reading will drop and the water feeding pressure (flow rate) will also drop.</p>

IMPORTANT

The flow circuit for pumped water must never be fully closed during operation (the Cold-Water inlet / outlet and the bypass valve must be open). (Control operation within the green range on the water pressure gauge.) Operation with the water circuit fully closed may cause the evaporator to freeze up or break, the pump to fail, or the hose to drop out.

Even if the water tank is full, the piping may contain air. If you start the product without discharging air, it may cause the evaporator to freeze inside and may cause an error signal (E 18 or E49) to be generated.

When supplying water, ensure that the water does not overflow onto the floor.

As a water-overflow prevention measures, we recommend that you undertake piping works for overflow or drain.

For piping works such as those for drains, contact service specialists qualified by Orion Machinery.

Operating Procedures

Preparation

Adjusting the water temperature

1. Switch on the power.

An "HELLO CHILLER..888" appears in the display. After a few seconds the display changes to indicate the current water temperature.

2. Set the desired water temperature.

(1) Hold the SET switch down for at least two seconds.

The current temperature setting will blink on the display.

(2) Use the adjustment switches to adjust the setting.

You can set to any value between 5 to 35

(3) Press the SET switch.

The setting is registered, and the display again shows the current (measured) temperature.

The temperature setting is stored in nonvolatile memory. You do not need to repeat the setting procedure each time you start up the product.

IMPORTANT

If "F99" (setting lock) is set to "1" (Setting lock), the water temperature cannot be changed. First change the "F99" setting to "0"(lock cancellation) before changing the water parameter (Default : 0).

"F15"(Energy-saving Mode) is set to "0"(High-accuracy Mode) as the default. Set "F15" to "1"(Energy-saving Mode), if it is necessary to select Energy-saving Mode because of a small amount of thermal load or other reasons. (See "Setting and Changing Parameters on page 22")

Operating Procedures

Local Operation (Operation from Control Plate)

Local Operation (Operation from Control Plate)

This mode is available when the parameter "F2" of this product is set to "0" or "2" (set to "2" by default).

Switching the product ON

Press the ON/OFF switch.

The Operation lamp lights up green to indicate that the product is running.

The thermostatic controller will automatically control operation to maintain constant water temperature.

Switching the product OFF

Press the ON/OFF switch again.

The Operation lamp turns off the lights, and the product is stops.

IMPORTANT

1. If the parameter "F2" for this product (selection between local and remote-control operation) is set to "1" (only the remote switch is available), the control plate is deactivated. (It is set to "2" by default.) See page 22 for how to change the setting.
2. Turning the power on generates a clicking noise inside the mechanical chamber, which is normally generated when initializing the electric expansion valve.
3. Excessively frequent starting-up and terminating operations may cause product failure. Be sure to pause for 3 minutes or longer between operations. Operating within 3 minutes after the last operation displays an alarm (E5).

Pump-Only Operation

1. Hold down the **switch** and press the ON/OFF switch.

The Operation lamp comes on to indicate that the pump is operating, and "POn" (for pump-only) appears in alternation with the measured-temperature value on the display.

2. To shut off the pump, press the ON/OFF switch once again.

The Operation lamp goes off to indicate that the pump has been shut off.

It is not possible to switch directly from pump-only operation to normal operation; you must first turn pump-only operation off as described above.

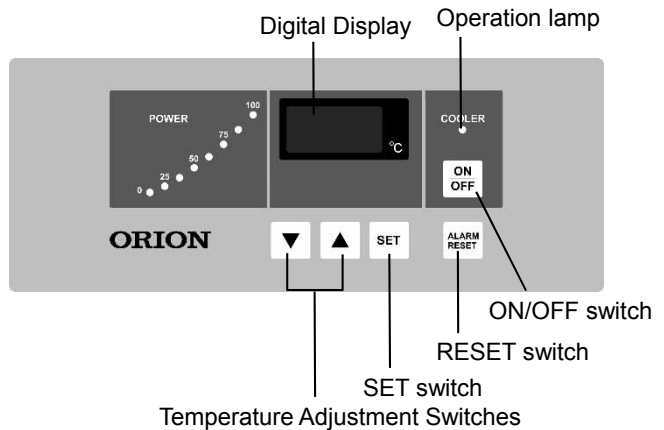

Operating Procedures

Remote Operation

Remote Operation

The following operating procedures are available when the parameter "F2" for this product is set to "1".

Switching the product ON

1. Set the remote switch ON (short the circuit). (Short the circuit between terminals 17 and 18.)

Switching the product OFF

1. Set the remote switch OFF (open the circuit). (Open the circuit between terminals 17 and 18.)

IMPORTANT

1. Before you can operate the product in Remote mode, you must have a qualified electrician set up the necessary wiring.
2. The remote control mode is not available when the parameter "F2" for this product (selection between local and remote-control operation) is set to "0" (only the local operation is available). (It is set to "2" by default.) See page 22 for how to change the setting.

Operating Procedures

Dual Mode (Operation in Combination of Local and Remote Modes) / Other Procedures

Dual Mode (Operation in Combination of Local and Remote Modes)

The following procedures are available when the parameter "F2" for this product is set to "2" (default).

Switching the product ON

1. **If the Remote switch is OFF (if the circuit is open between terminals 17 and 18) and the product is deactivated:**

Press the ON/OFF switch on the control plate or turn the Remote switch ON (to short the circuit between terminals 17 and 18) to start up the product.

2. **If the Remote switch is ON (if the circuit is shorted between terminals 17 and 18) and the product is deactivated:**

Press the ON/OFF switch on the control plate or turn the Remote switch OFF (to open the circuit between terminals 17 and 18 for one minute or longer) and then turn the switch ON again (to short the circuit between terminals 17 and 18) to start up the product.

Switching the product OFF

1. **If the Remote switch is ON (if the circuit is shorted between terminals 17 and 18) and the product is operating:**

Press the ON/OFF switch on the control plate or turn the Remote switch OFF (to open the circuit between terminals 17 and 18) to stop the product.

2. **If the Remote switch is OFF (if the circuit is open between terminals 17 and 18) and the product is operating:**

Press the ON/OFF switch on the control plate or turn the Remote switch ON (to short the circuit between terminals 17 and 18 for one minute or longer) and then turn the switch OFF again (to open the circuit between terminals 17 and 18) to stop the product.

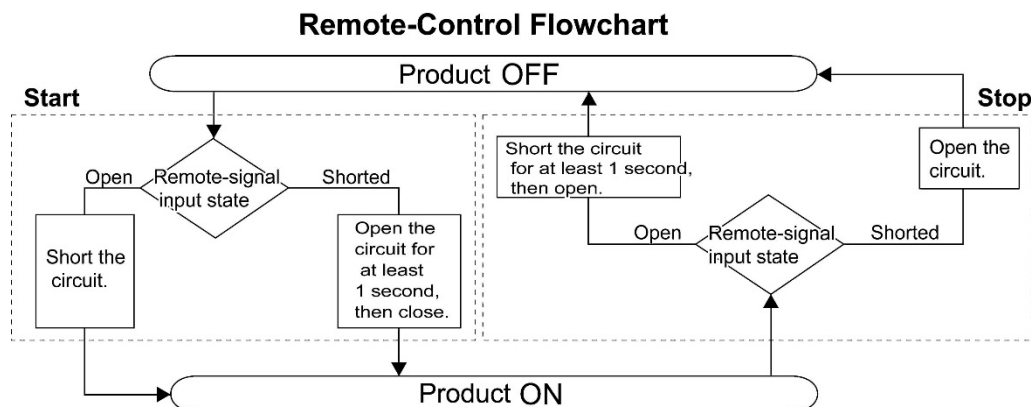

Operating Procedures

Other

Other

ALARM Signal

Occurrence of an alarm condition causes the product to output the ALARM signal, and at the same time generates an error code on the digital display. (Refer to page 77 "Setting Up to Use Remote Operation and External Signals")

Note : Condition "E00" "E2" "E55" does not generate output of the ALARM signal.

Usage Precautions

1. Be sure that water remains clean. Periodically wash or clean the water circuit, the condenser, and other components that are in regular contact with water.
2. If a safety device is tripped, the product will stop operating and an error code will appear on the display. Note down the code, then switch off the main power. Then correct the problem (refer to the " Diagnosing and Troubleshooting Unit Failure or Abnormalities " section, starting on page 47, for advice). Once the problem is cleared, you can restart operation.

Note : For information about each code, refer to the " Diagnosing and Troubleshooting Unit Failure or Abnormalities " section.

3. The water level in the tank may drop quickly (an "E06" error may occur) the first time you operate the product, or if piping is very long. If this occurs, add more water to the tank and then press the RESET switch to clear the error.
4. Never use the power switch or power cord for the purpose of switching the product ON and OFF. Using the power connection in this way may damage the product.

Freeze-Prevention of Cold Water

If freezing of the water is feared at the time of operation stop during the cold-weather periods, take the following freeze-prevention measures.

1. Freeze-Prevention of Cold Water Side

The Freeze-Preventive Operation is to operate the pump automatically in order to prevent the decreasing of water temperature and the freezing of water in the water tank and the piping during the cold-weather periods.

(1) Freeze-Preventive Operation Mode

Water temperature	3 or lower	3 to 10	10 or higher
Pressure pump operation condition	Continuous operation The water temperature is increased by the generation of pressure pump, and it stops when the water temperature becomes 5	Repeat the cycle of 28 minutes stop and 2 minutes operation	Stop

(2) As for operation method of the freeze-prevention, refer to [F10] With/Without Freeze-Preventive Operation on page 25.

IMPORTANT

When it is not possible to supply the main power, such as during the night time, totally drain water from the water tank and the water piping. Refer to the section "Storing the Product" indicated on page 62 regarding the water draining method.

Operating Procedures

Operation by Remote Control(Optional)

Operation by Remote Control(Optional)

Remote control is available at the remote control operation mode and parallel use operation mode (the setting of parameter [F2] is “1” or “2”).

As for the application and connection method, refer to the attached instruction manual and the installation instruction.

Function of Remote Control

To connect the remote control with the product, it is possible to operate and display the same as the product control plate with limitations.

1. Limitations of remote control

(1) The following setting change cannot be available in the parameter function. In case of changing the set value, set it by the control plate.

[F2] (local/remote operation preference)

[F90] (communication device address)

(2) One remote control cannot operate plural products. Be sure to prepare one remote control per one product.

2. Error display

Other than the error display of product, the digital display of remote control becomes the following if the error activates the connection of remote control and product.

Contents of errors	Digital display	Note
Power supply line of wiring is disconnected.	No display	Without switch buzzer
Power supply of product is turned OFF.	No display	Without switch buzzer
The communications is abnormal	< - - - >	<ul style="list-style-type: none">• Receiving data is abnormal.• No response from product or Wiring is disconnected.
CPU runaway by the disturbance like electromagnetic wave.	Start from initial operation	Reset the CPU by runaway detection function.

Operating Procedures

Operation by Remote Control(Optional)

Operation by Remote Control(Optional)

IMPORTANT

1. In case of changing the product communication device address, the communication device address of the remote control has to be changed to be the same as the product communication device address. The remote control cannot be operated since the both addresses are not the same.
2. Install the remote control in a place where not come in contact with water since the remote control is not waterproofing.
3. In case of connecting with the remote control, the remote control (wired) set B and the remote control code is necessary. Place an order referring to P67 "Options".

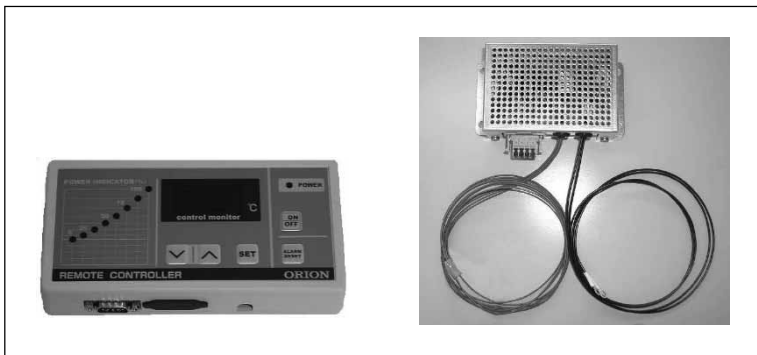

Remote control (wired) set B



Remote control code

Safety Devices

Device	Function	Error Display	Product State ¹ (Alarm handling pattern)	Corrective Action
High-Pressure Switch	Activates if refrigerant pressure becomes too high (due to high ambient temperature, malfunction of fan motor, etc.). Shuts down the compressor by cutting the circuit.	E 02	2 (3)	Refer to the "Diagnosing and Troubleshooting Unit Failure or Abnormalities" section starting on page 47.
Fan Inverter (U) Alarm	Activates if malfunction or overcurrent occurs at the fan motor. Shuts down the compressor by cutting the circuit.			
Compressor 1 Overcurrent Relay	Activates if malfunction or overcurrent occurs at the compressor 1 motor. Shuts down the compressor 1 by cutting the circuit.	E 03	5 (3)	
Compressor 2 Overcurrent Relay	Activates if malfunction or overcurrent occurs at the compressor 2 motor. Shuts down the compressor 2 by cutting the circuit.	E 70	5 (3)	
Overcurrent Relay for Pump	Activates if malfunction or overcurrent occurs at the pump motor. Shuts down the entire product by cutting the circuit.	E 05	3	
Float Switch	Shuts down the entire product when the water level in the tank goes down.	E 06	3	
Fuse	Protects the control board by blowing the fuse when an over-current occurs on the control board.	R-phase: E 05 Each phase: E 09	R-phase: 3 Each phase: 3	

¹ "Actions in Response to Alarms" on page 48 describes what the figures in the "Product State (Alarm handling pattern)" column represent.

The figures in parentheses in this column represent states when the "F4" parameter is set to "0".

Monitoring

Displaying Temperature Setting / Displaying Refrigerator State

Displaying Temperature Setting

Pressing the SET switch on the control plate displays the water temperature setting for several seconds in the digital display.

Displaying Refrigerator State

This product can display operational data in the digital display on the control plate.

1. Hold down the SET switch on the control plate for 7 seconds to switch the temperature setting blinking on the digital display to alternate display of "Td" and the "compressor discharging temperature".
2. Press the Temperature Adjustment switch () to display and and in turn, and the Temperature Adjustment switch () to display and and in turn.
 - Alternate display of "Td" and the "refrigerant discharging temperature" (Unit :)
 - Alternate display of "Ts" and the "refrigerant suction temperature" (Unit :)
 - Alternate display of "Pd" and the "refrigerant discharging pressure" (Unit : MPa)
 - Alternate display of "Ps" and the "refrigerant suction pressure" (Unit : MPa)
 - Alternate display of "CAP" and the "compressor 1 capacity output" (Unit : %)
 - Alternate display of "Fr" and the "fan frequency" (Unit : Hz)
 - Alternate display of "EEV" and the "electric expansion valve aperture" (Unit : PPs)
 - Alternate display of "SH" and the "suction refrigerant overheat" (Unit : deg.)
 - Alternate display of "TE" and the "refrigerant evaporation temperature" (Unit :)
 - Alternate display of "Tb" and the "distributing board internal temperature" (Unit :)
 - Alternate display of "Hr" and the "accumulated operating hours" (Unit : 100Hr)
 - Alternate display of "AL 1" and the "last alarm"
 - Alternate display of "AL 2" and the "first alarm before the last"
 - Alternate display of "AL 3" and the "second alarm before the last"
 - Alternate display of "AL 4" and the "third alarm before the last"
 - Alternate display of "AL 5" and the "fourth alarm before the last"
 - Alternate display of "AL 6" and the "fifth alarm before the last"
3. Press the RESET switch to return to the measurement temperature display.

Parameters

Setting and Changing Parameters

Setting and Changing Parameters

On this product, you can select a range of functions by setting parameters.

Procedure

The following is an example of the parameter setting for displaying the "F5" (Alarm With/Without Buzzer) setting value and changing the parameter setting. To change the default value "1" (with buzzer) to "0" (without buzzer):

1. Press the Temperature Adjustment switch () while holding down the Temperature Adjustment switch ().	The parameter display mode is invoked. <On the digital display> "F1" and the "F1 setting value" appear in turn.
2. Press the Temperature Adjustment switch () or () to display "F5".	<On the digital display> "F5" and "1" appear in turn.
3. Hold down the SET switch for 5 seconds.	<On the digital display> "1" appears continuously.
4. Press the Temperature Adjustment switch () or () to change "1" to "0".	<On the digital display> "0" appears continuously.
5. Press the SET switch.	The setting change is finalized. <On the digital display> "F5" and the "0" appear in turn.
6. Press the RESET switch.	<On the digital display> The measurement temperature display mode is restored.

The other parameters can also be displayed by step (3) and changed by steps (3) and on.

IMPORTANT

If "F99" (setting lock) is set to "1", the parameters cannot be changed.

First change the "F99" setting to "0" before changing the other parameters.

Parameters

Parameter Types and Functions

Parameter Types and Functions

Parameter list (Setting change is available while the product is in operation).

Parameter Number	Name	Setting Range	Unit	Min.	Default
F1	Power Suspension Recovery	0 to 2	-	1	0
F2	Local/Remote Operation Preference	0 to 2	-	1	2
F3	Alarm Signal Output	0, 1	-	1	0
F4	Action at Product Alarm	0, 1	-	1	1
F5	Alarm With/Without Buzzer	0, 1	-	1	1
F6	Caution Alarm With/Without Buzzer	0, 1	-	1	1
F7	These are exclusive parameters for makers. Please do not change.				
F8					
F10	With/Without Freeze-Preventive Operation	0, 1	-	1	0
F11	With/Without Warm-up Operation	0, 1	-	1	0
F12	Warm-up Temperature Setting	10 to 35		0.1	20.0
F13	Snow Coverage Prevention Mode	0, 1	-	1	0
F14	Low noise operation mode option	0, 1	-	1	0
F15	Energy-saving Mode	0, 1	-	1	0
F20	Upper/Lower Liquid Temperature Limit Alarm	0 ~ 4	-	1	0
F21	Upper/Lower Liquid Temperature Limit Alarm - Relative Value	1.0 to 5.0		0.1	5.0
F22	Upper/Lower Liquid Temperature Limit Alarm - Maximum Absolute Value	F23+2 to 40		0.1	35.0
F23	Upper/Lower Liquid Temperature Limit Alarm - Minimum Absolute Value	0 to F22 - 2		0.1	5.0
F30	With/Without 500-hour Filter Use Caution Alarm	0, 1	-	1	1
F90	Communications Device Address	0 to 31	-	1	0
F99	Setting Lock	0, 1	-	1	0

* F12, F21, F22, and F23 are displayed when each function is valid. Refer to the next clauses in detail.

Detailed Descriptions of Parameter Functions

F1 : Power Suspension Recovery (Related parameter : F2)

Use this parameter to select a desired recovery pattern for this product from the power suspension.

F1 Setting	Pattern Name	Pre-Power Suspension State	Recovery Action	Alarm Display at Recovery
0	Manual Recovery	Running	Total shutdown	E14
		Shutdown	Total shutdown	None
1	Automatic Recovery	Running	Automatic restart	None
		Shutdown	Total shutdown	None
2	Remote Switch-Controlled Recovery	Running	Automatic restart when the remote switch is ON	None
			Total shutdown when the remote switch is OFF	None
		Shutdown	Automatic restart when the remote switch is ON	None
			Total shutdown when the remote switch is OFF	None

Default : 0

Parameters

Parameter Types and Functions

<Setting Limitations>

Depending on the F2 setting, the F1 setting is limited to the values below.

F2 Setting	Values Available for F1
0	0, 1
1	2
2	0, 1, 2

F2 : Local/Remote Operation Preference (Related Parameter : F1)

Use this parameter to select the ON/OFF switch that (for the product) you want to activate between the switch on the control plate and the remote switch.

F2 Setting	Function	Initial F1 Value ²
0	Only enables local operation.	0
1	Only activates the remote switch.	2
2	Enables both. ¹	0

Default : 2

- 1 Enables you to turn the product on/off from either local or remote-control operation.
If the remote switch is set ON (or OFF), you can turn the product off (or on) with the local switch.
- 2 Note that changing F2 automatically turns to this initial value.
You can change F1 after setting F2.

F3 : Alarm Signal Output

Use this parameter to select contact specifications applied to the remote alarm signal terminals 15 and 16 at alarm output.

F3 Setting	Function
0	Closes contact at alarm output.
1	Opens contact at alarm output.

Default : 0

- 1 Both settings open contact if the main power is shut down.

F4 : Action at Product Alarm

Use this parameter on available devices to select between the total product shutdown and the partial operation.

F4 Setting	Function
0	Totally shuts down the product.
1 ¹	Continues operation on available devices.

Default : 1

- 1 For alarms and the relevant product actions, see "Alarm Handling List" on page 47.

Parameters

Parameter Types and Functions

F5 : Alarm With/Without Buzzer (Related parameter : F6)

Use this parameter to specify if the alarms accompany a buzzing sound or not. (Available for all alarms except for C64 and C65.)

F5 Setting	Function
0 1	Generates an alarm without a buzzing sound.
1 2	Generates an alarm with a buzzing sound.

Default : 1

- 1 The F6 setting is disabled if this parameter is set to "0".
- 2 C64 and C65 does not accompany a buzzing sound regardless of the setting.

F6 : Caution Alarm With/Without Buzzer

Use this parameter to specify if the C * *-type caution alarm accompanies a buzzing sound or not.

F6 Setting	Function
0	Generates a caution alarm without a buzzing sound.
1	Generates a caution alarm with a buzzing sound.

Default : 1

- 1 Only available for caution alarms that is labeled " C * *". (C64 and C65 does not accompany a buzzing sound regardless of the setting.)
- 2 The F6 setting is disabled if F5 is set to "0" (Alarm Without Buzzer).
- 3 Only when F5 is set to "1" (Alarm With Buzzer), F6 setting can be changed.

F10 : With/Without Freeze-Preventive Operation (Related parameter : F11)

This function, the Freeze-Preventive Operation mode, prevents the tank water temperature from dropping and water from freezing in the piping during winter by automatically operating the pressure pump.

F10 Setting	Function
0	Without Freeze-Preventive Operation
1	With Freeze-Preventive Operation

Default : 0

- 1 With this parameter set to "1" (With Freeze-Preventive Operation), the pressure pump operates as shown in the table below, depending on the water temperature measurement. While the pressure pump is operating, the Operation lamp blinks.

Water temperature	3 or lower	3 to 10	10 or higher
Pressure Pump operation condition	Continuous operation The water temperature is increased by the generation of pressure pump, and it stops when the water temperature becomes 5	Repeat the cycle of 28 minutes stop and 2 minutes operation	Stop

- 2 There are following procedure for the pressure pump stop during the Freeze-Preventive Operation : Change this parameter setting to "0" (Without Freeze-Preventive Operation) to stop the pressure pump during operation.
- 3 When this parameter is set to "1" (With Freeze-Preventive Operation), the decimal point in the digital display blinks once in a second, indicating that the Freeze-Preventive Operation is specified.
- 4 If F11 is set to "1" (With Warm-up Operation), F10 cannot be manipulated.

Parameters

Parameter Types and Functions

IMPORTANT

1. Since the liquid temperature sensor resides inside this product, the external piping may require modification such as adding adequate thermal insulation to protect it from freezing.
2. Check that the water level in the tank is high enough; Freeze-Preventive Operation is disabled if the E06 alarm is generated upon detection of a low water level in the tank.
3. When you have set this parameter to "With Freeze-Preventive Operation", ensure that the piping is not totally closed. It would not only affect the freeze-preventive performance but also cause the water pressure to increase excessively when the pressure pump is operating, which in turn may lead to failure including water leakage.
4. Use the Warm-up Operation (F11) to prevent freeze-up when the ambient temperature is less than -5 during shutdown. Note, however, that this operating mode cannot prevent freezing when the ambient temperature is less than -20 or lower.
5. Be sure to operate the product within the ambient temperature range of -5 to +43. Operating the product other than above ranges may cause failures on the compressor and other devices.

F11 : With/Without Warm-up Operation (Related parameters : F10 and F12)

The Warm-up Operation function automatically operates the pressure pump in order to prevent water temperature drop during shutdown when the ambient temperature is low as in winter and to maintain the tank water temperature specified with F12.

This function helps reduce waiting time until the water temperature becomes high enough at start-up.

F11 Setting	Function
0	Without Warm-up Operation
1	With Warm-up Operation

Default : 0

- 1 There are following procedure for the pressure pump stop during the Warm-up Operation :
Change this parameter setting to "0" (Without Warm-up Operation) to stop the operating pressure pump during operation.
- 2 When this parameter is set to "1" (With Warm-up Operation), the decimal point in the digital display blinks 4 times per second, indicating that the Warm-up Operation is specified.
- 3 If F10 is set to "1" (With Freeze-Preventive Operation), F11 cannot be manipulated.

IMPORTANT

1. Check that the water level in the tank is adequately high; the Warm-up Operation is disabled if the E06 alarm is generated upon detection of a low water level in the tank.
2. When you have set this parameter to "With Warm-up Operation", ensure that the piping is not totally closed. It would not only affect the freeze-preventive performance but also cause the water pressure to increase excessively when the pressure pump is operating, which in turn may lead to failure including water leakage.

Parameters

Parameter Types and Functions

F12 : Warm-up Temperature Setting (Related parameter : F11)

Setting F11 to "1" automatically restarts the pressure pump while this product is shut down in order to maintain water temperature specified with this parameter.

F12's setting range : 10.0 - 35.0 (Min. setting unit : 0.1)

Default : 20.0

- 1 The pressure pump starts operating at a temperature 2.0 lower than the F12 temperature setting, and stops at a temperature 2.0 higher than the same.

F13 : Snow Coverage Prevention Mode

This function prevents snow cover at the upper section of this product's exhaust port by automatically operating the fan periodically (without any display on the control plate).

F13 Setting	Function
0	Deactivates the snow cover prevention feature
1	Activates the snow cover prevention feature

Default : 0

- 1 Set this parameter to "A1" to operate the fan by itself while the system is suspended. Repeats a cycle of 27minutes stop and 3minutes operation.
- 2 There are following procedure for the fan stop during the Snow Coverage Prevention Operation: Change the setting to "0" (to deactivate the snow cover prevention feature) to stop the fan.



WARNING

Be sure to cut of the main power before detaching the cabinet for inspection or maintenance. You could get caught in the fan's rotating section, which could lead to a serious injury.

"F014" Low noise mode select

Reduces the fan noise is lowered by reducing the maximum fan speed to 40Hz (normally 60Hz). Note that in this mode, compressor output (cooling capacity) will drop to a maximum of 80%.

"F014" settings	Description
Normal mode	Select the desired option.
Low noise mode	

Factory default setting: Normal mode.

- 1 If the outside air temperature is low, the fan speed will be low, even when in "Normal mode". Therefore under such conditions, the noise level might not be reduced even if the "Low noise mode" is enabled.
- 2 After changing the low noise mode setting, please stop and then restart operation in order to activate the desired mode. Changing the mode during operation may cause the high pressure switch to be activated (resulting in error condition E002) and the unit may shut down.

F15 : Energy-saving Mode

This function helps energy saving by stopping the compressor when the cooling load is low.

The reference value of cooling load for effectively operating in this mode is about 30% of the rated cooling capacity (which is stated on the specification plate affixed on this product's front side left-hand area). (Note that it varies slightly depending on the ambient temperature and water temperature setting.) This function is useful for a scenario with a high maximum cooling load and occasional decreases in cooling load.

(Nothing is displayed on the control plate.)

F15 Setting	Function
0	High-accuracy Mode
1	Energy-saving Mode

Default : 0

- 1 In Energy-saving mode, the liquid temperature changes around ± 2.0 of the liquid temperature setting as the compressor repeats operation and suspension.
- 2 In High-accuracy mode, the compressor does not stop even when the cooling load is low, maintaining the liquid temperature change within ± 1.0 of the liquid temperature setting.

IMPORTANT

When the external temperature is low, inadequate thermal insulation of the external piping may lead to a drop in the liquid temperatures exceeding the above stated range.

Parameters

Parameter Types and Functions

F20 : Upper/Lower Liquid Temperature Limit Alarm (Related parameters : F21, F22 and F23)

Use this parameter to specify the method of detecting abnormal liquid temperatures. Use F21, F22 and F23 to set temperatures to be detected.

F20 Setting	Function	
0	No alarm detection	
1	Alarm on relative values	With a stand-by sequence
2		Without a stand-by sequence
3	Alarm on absolute values	With a stand-by sequence
4		Without a stand-by sequence

Default : 0

- 1 The alarm display on the control plate is "CO7". This product continues operation even when an alarm is displayed. For details, see "Alarm Handling List" on page 47.
- 2 If a stand-by sequence is set, this parameter outputs an alarm when the liquid temperature attains an abnormal value after a normal value is established after start-up.
- 3 No alarm detection is performed while this product is shut down.

<Effect of a stand-by sequence>

1. When set to "1":

No alarm is output even when the start-up temperature exceeds the range set with F21.

An alarm is output when the temperature exceeds the range set with F21 after attaining a value within that range after start-up.

2. When set to "3":

No alarm is output even when the start-up temperature exceeds the range set with F22 or F23.

An alarm is output when the temperature exceeds the range set with F22 or F23 after attaining a value within ± 1.0 of the water temperature setting after start-up.

When operating with a stand-by sequence, press the RESET switch on the control plate to reset the output alarm. In this case, the product enters the state described above, outputting an alarm when the product enters the state .

F21: Upper/Lower Liquid Temperature Limit Alarm - Relative Value (Related parameter : F20)

This parameter setting takes effect when F20 is set to "1" or "2".

This function outputs an alarm based on a relative value against the liquid temperature setting.

F21 setting range : 1.0 to 5.0 (Min. setting unit : 0.1)

Default : 5.0

- 1 For example, if set to "3.0 ", an alarm is output when the water temperature exceeds ± 3.0 of the setting value.

Parameters

Parameter Types and Functions

F22 : Upper/Lower Liquid Temperature Limit Alarm - Maximum Absolute Value (Related parameters : F20 and F23)

This parameter setting takes effect when F20 is set to "3" or "4".

Regardless of the water temperature setting, this parameter outputs an alarm when the liquid temperature exceeds the temperature setting for this parameter.

F22 setting range : The F23 setting + 2.0 to 40.0 (Min. setting unit : 0.1)

Default : 35.0

F23 : Upper/Lower Liquid Temperature Limit Alarm - Minimum Absolute Value (Related parameters : F20 and F22)

This parameter setting takes effect when F20 is set to "3" or "4".

Regardless of the water temperature setting, this parameter outputs an alarm when the liquid temperature exceeds the temperature setting for this parameter.

F23 setting range : 0 to the F22 setting -2.0 (Min. setting unit : 0.1)

Default : 5.0

F30 : With/Without 500-hour Filter Use Caution Alarm

The 500-hour filter use caution alarm notifies the timing for cleaning the condenser filters. When the operating hours exceed 500 hours, the control plate displays "C00".

This product continues operation when and after this caution alarm is generated.

For details, see "Alarm Handling List" on page 47.

F30 Setting	Function
0	Specifies operation without a caution alarm
1	Specifies operation with a caution alarm

Default : 1

F90 : Communications Device Address

When a number of units of this model are connected via the communications functionality, use this parameter to set their address numbers.

Address numbers can be set between 0 and 31, allowing up to 32 units to be connected.

Default : 0

1 For details of the communications functionality, see "Communications" on page 30.

F99 : Setting Lock

Use this parameter to prohibit changing the water temperature setting and the parameter settings.

F99 Setting	Function
0	Cancels setting lock
1	Setting locks

Default : 0

Communications

Overview of Communications Function

Overview of Communications Function

This product can be connected to a personal computer to control the product from this single PC, using communications software installed on the PC. You can operate and monitor various operations of up to 32 units from a single PC. In addition, you can configure your own control program based on the communications specifications described in the following section to utilize the communications functionality according to your needs.

The following section describes the overview of the communications software. For details, see the operation manual shipped with the software.

Operating Environment

1. OS : Microsoft Windows
2. Display : 800 x 600 dots or better.

Controlling Functions

1. Running and stopping this product
2. Pump-only operation (only when this product itself is shut down.)
3. Setting and changing water temperature

Display Function

1. Display of this product's operating state
2. Display of pump-only operating state
3. Display of water temperature setting and measurement values
4. Alarm display

Other functions

1. Graphical display of water temperature measurement changes
2. Operational data saving

IMPORTANT

1. If the F2 parameter (Local/Remote Operation Preference) is set to "0" (Only enables local operation), this product cannot be operated or stopped via the communications functionality.
2. If the F99 parameter (Setting Lock) is set to "1" (setting locks) the water temperature cannot be set or changed via the communications functionality.
3. Refer to change this product's parameter setting, see page 22.
4. Install separate communications cabling apart from the power cable and cords. Binding them together may cause communications errors due to possible noise.
5. When it is changed setting of by communication, give me 100,000 times of setting change number of times as the following.
When it is any further, the memory number of times of the control board becomes the life and causes the trouble.

Communications

Overview of Communications Function

Communications Standards

1. Compliant with the EIA Standard RS-422A/485.
2. Compliant with the EIA Standard RS-232C.

Communications Style

1. RS-422A : Via 4-line multi-drop connection.
2. RS-485 : Via dual-line multi-drop connection
3. RS-232C : Via point-to-point connection.

Baud Rate

9600 bps

Data Format

Start bit : 1 Data bit : 8
Parity bit : None Stop bit : 1

Error Control

Longitudinal parity check

Maximum Number of Units Connected

1. RS-422A : 32 units
2. RS-485 : 32 units
3. RS-232C : one unit

Besides the connecting methods using either (1) or (2) above, up to 32 units can be connected by using the RS-232C connection for the host computer and the RS-422A (or RS-485) connectors for connection among the products. (See "Communications Cables and Connectors" on page 40.)

Data Types

1. Text : JIS (ASCII) 7-bit code
2. Control Code

Signal Name	Code (Hexadecimal)	Meaning
STX	02h	Start of Text
ETX	03h	End of Text
EOT	04h	End of Transmission
ENQ	05h	Enquiry
ACK	06h	Acknowledge
NAK	15h	Negative Acknowledge

Connector Signals

1. RS-422A/485 (Connector label within the distributing board : RS422A/485)

Pin Number	Signal Name	Meaning
1	SG	Signal ground
2	RDB(+)	Outgoing data
3	RDA(-)	Outgoing data
4	SDB(+)	Incoming data
5	SDA(-)	Incoming data

RS-485 is used by connecting RDA(-) and SDA(-), and RDB(+) and SDB(+), respectively.

Communications

Overview of Communications Function

2. RS-232C

D sub (Connector label within the distributing board : RS232C)

Pin Number	Signal Name	Meaning
1		
2	TXD	Outgoing data
3	RXD	Incoming data
4		
5	SG	Signal ground
6		
7	CTS	Transmission ready
8	RTS	Transmission request
9		

• Please use the straight cable for the connection with the personal computer.

Communications Pin Layout inside the Distributing Board

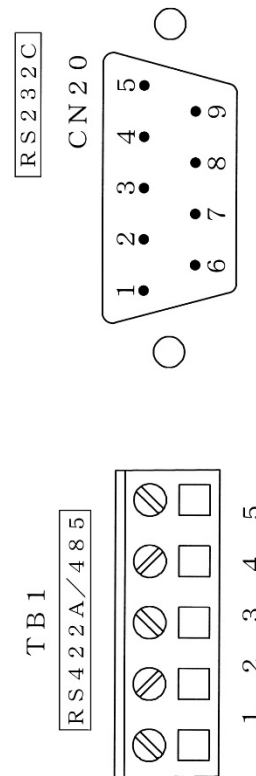
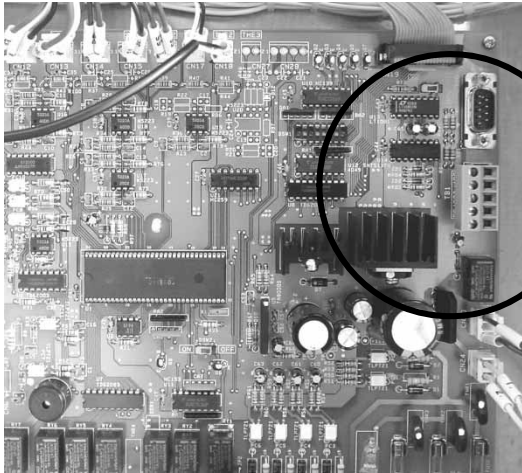

Numbers on each connector represent connector pin numbers.

Communications

Overview of Communications Function

Signal Logic

1. RS-422A/485

Signal Voltage	Logic
$V(A) > V(B)$	0 (Blank space)
$V(A) < V(B)$	1 (Marked)

2. RS-232C

Signal Voltage	Logic
+3V and over	0 (Blank space)
-3V and less	1 (Marked)

Data Structure

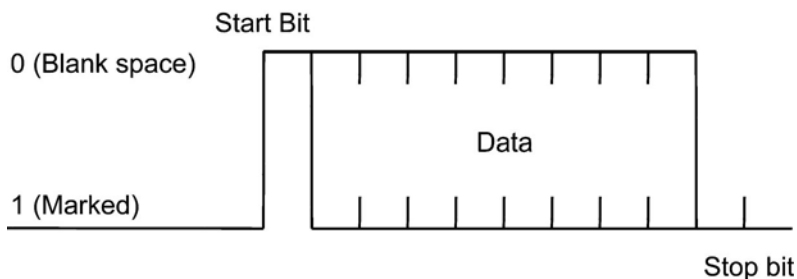

Communications Protocol

This product uses the polling/selecting method for establishing the data link.

1. Polling :

This is an action of the host computer to select this product and requests for data transmission.

Transmission from the host

Transmission from this product

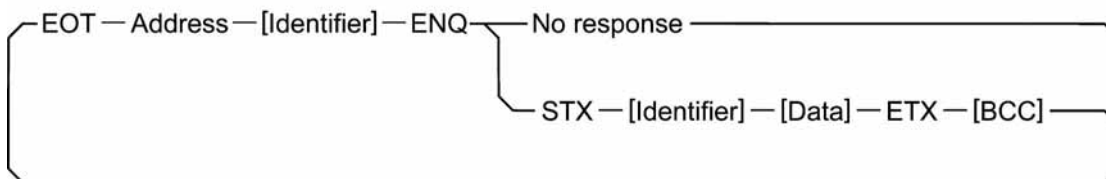

(1) Polling procedure

Initializing the data link.

The host computer transmits EOT to initialize the data link before transmitting polling sequence.

Polling sequence transmission

[Address] - [Identifier] - ENQ

- [Address] : Device address of the equipment (this product)
2-digit decimal JIS characters (00 - 31).
- [Identifier] : Code for identifying data.
2-digit alphanumerical JIS characters
See "Communications Identifiers At a Glance".
- ENQ : Transmission control characters that indicate the end of the polling sequence.
After this step, the host computer enters the waiting state for a response from this product.

Communications

Overview of Communications Function

Data transmission from this product

STX - [Identifier] - [Data] - ETX - [BCC]

- STX : Transmission control character that indicates the start of the text.
- [Identifier] : Code for identifying data
2- digit alphanumerical JIS characters
See the "Communications Identifiers At a Glance".
- [Data] : Data identified by this product's identifiers
Eight-digit JIS characters
- ETX : Transmission control character that indicates the end of the text.
- [BCC] : Error-detecting block check characters for longitudinal parity check.
EX-OR of all characters from the character following the STX to the ETX.

2. Selecting

The action of the host computer to select this product and transmit data.

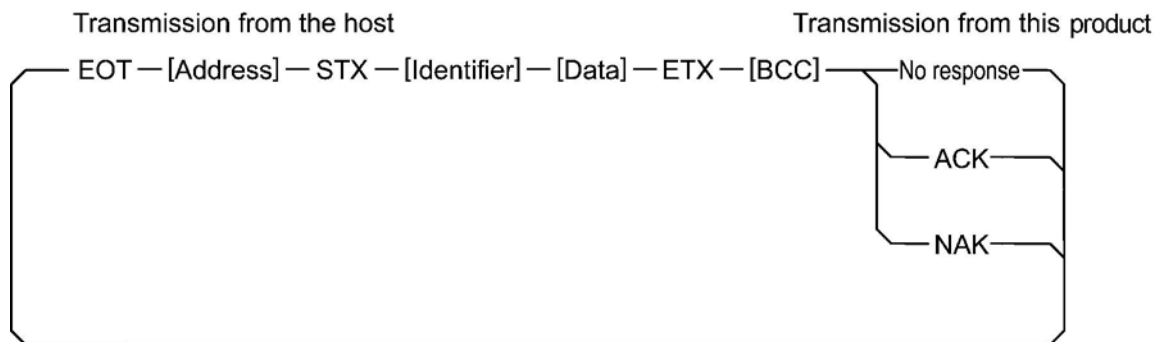

(1) Selecting procedure

Initializing data link

The host computer transmits EOT to initialize the data link before transmitting the selecting sequence.

Transmitting selecting sequence

[Address] - STX - [Identifier] - [Data] - ETX - [BCC]

- [Address] : The device address of the equipment subject to polling (this product).
2-digit decimal JIS characters (00 - 31).
- STX : Transmission control character that indicates the start of the text.
- [Identifier] : Code for identifying data
2-digit alphanumerical JIS characters
See the "Communications Identifiers At a Glance".
- [Data] : Data identified by this product's identifiers (in the same format as for polling).
Eight-digit JIS characters
- ETX : Transmission control character that indicates the end of the text.
- [BCC] : Error-detecting block check characters for longitudinal parity check.
EX-OR of all characters from the character following the STX to the ETX.

Response from this product

- ACK : Affirmative response (returned when this product succeeded in reception)
- NAK : Negative response (returned when this product failed in reception)

Communications

Overview of Communications Function

Communications Identifiers At a Glance

Identifier	Contents	Data Range	Polling	Selecting
M1	Water temperature measurement	-99.9 to 99.9		×
S1	Water temperature setting	5 to 35 (Min. setting unit : 0.1)		
J \bar{O}	Operating state	0 : Shut down 1 : Run 2 : Pump-only operation		
ER	Alarm signal	Displayed alarm numbers		×

Communications Data Structure

1. M1 water temperature measurement and S1 water temperature setting

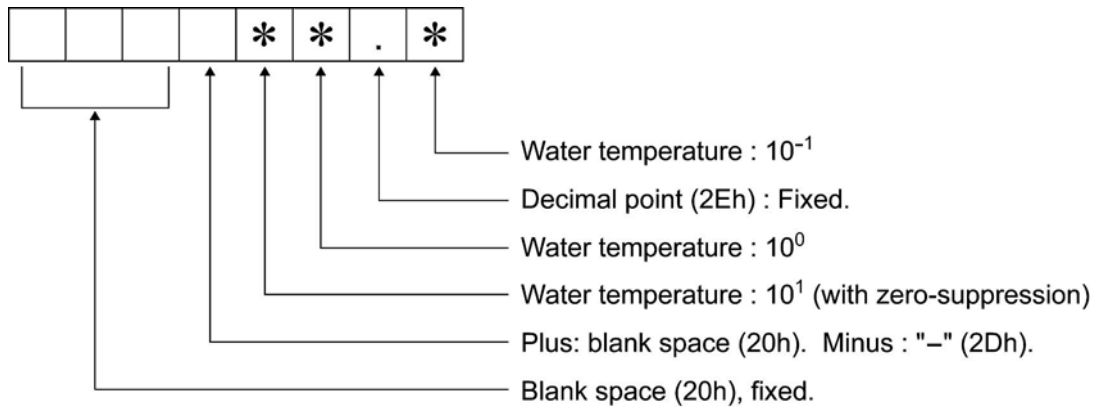

Example) 25.3°C					2	5	.	3
	20h	20h	20h	20h	32h	35h	2Eh	33h
Example) 5.0°C						5	.	0
	20h	20h	20h	20h	20h	35h	2Eh	30h
Example) -3.4°C				—		3	.	4
	20h	20h	20h	2Dh	20h	33h	2Eh	34h

2. J \bar{O} Operating state

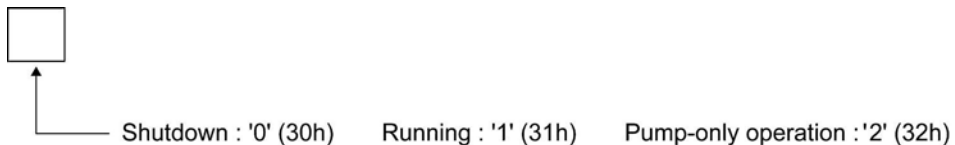

Communications

Overview of Communications Function

3. ER alarm signal

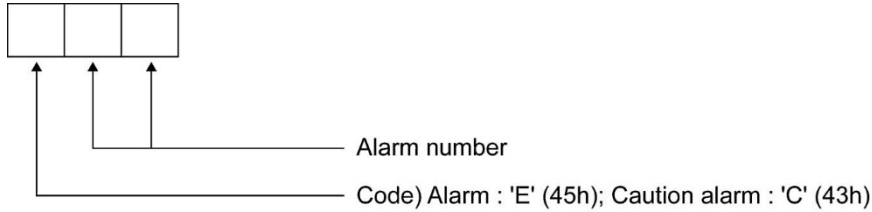

Example) C64

C	6	4
43h	36h	34h

Example) E05
(without zero-suppression)

E	0	5
45h	30h	35h

Example) No alarm

20h	20h	20h

Sample Communications Procedure

1. Polling

- (1) The host computer makes request to this product (device address : 05) for a water temperature measurement, and this product transmits the water temperature measurement data (12.3).

Transmission from the host

EOT	Address		Identifier		ENQ
	0	5	M	1	
04h	30h	35h	4Dh	31h	05h

Transmission from this product

STX	Identifier		Data								ETX	BCC
	M	1					1	2	.	3		
02h	4Dh	31h	20h	20h	20h	20h	31h	32h	2Eh	33h	03h	61h

Communications

Overview of Communications Function

- (2) The host computer makes request to this product (device address : 27) for the temperature setting, and this product transmits that data (20.0).

Transmission from the host

EOT	Address		Identifier		ENQ
	2	7	S	1	
04h	32h	37h	53h	31h	05h

Transmission from this product

STX	Identifier		Data								ETX	BCC
	S	1					2	0	.	0		
02h	53h	31h	20h	20h	20h	20h	32h	30h	2Eh	30h	03h	7Dh

- (3) The host computer makes request to this product (device address : 00) for the operating state, and this product transmits that data (pump-only operation).

Transmission from the host

EOT	Address		Identifier		ENQ
	0	0	J	0̄	
04h	30h	30h	4Ah	4Fh	05h

Transmission from this product

STX	Identifier		Data	ETX	BCC
	J	0̄	2		
02h	4Ah	4Fh	32h	03h	34h

- (4) The host computer makes request to this product (device address : 01) for the alarm number, and this product transmits that data (E05).

Transmission from the host

EOT	Address		Identifier		ENQ
	0	1	E	R	
04h	30h	31h	45h	52h	05h

Transmission from this product

STX	Identifier		Data			ETX	BCC
	E	R	E	0	5		
02h	45h	52h	45h	30h	35h	03h	54h

Communications

Overview of Communications Function

2. Selecting

(1) S1 water temperature setting

The host computer selects this product (device address : 27) and changes the water temperature setting by transmitting new setting data (20.0).

Transmission from the host

EOT	Address		STX	Identifier		Data								ETX	BCC
	2	7		S	1					2	0	.	0		
04h	32h	37h	02h	53h	31h	20h	20h	20h	20h	32h	30h	2Eh	30h	03h	37h

Transmission from this product

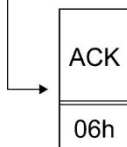

If any error is detected with the data, this product returns NAK (15h).

- Example)
- The number of data does not match.
 - BCC result reports an error.
 - The decimal point is placed wrong.
 - Data outside the relevant range were transmitted.

(2) J \bar{O} operating state

The host computer selects this product (device address : 01) and transmits the operating state '1' to start operation.

Transmission from the host

EOT	Address		STX	Identifier		Data	ETX	BCC
	0	1		J	0	1		
04h	30h	31h	02h	4Ah	4Fh	31h	03h	37h

Transmission from this product

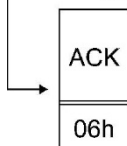

- The host confirms the Running and Alarm states by polling, and then perform selecting.

Example) This product returns NAK if the operating state '1' is selected during pump-only operation (state '2').

In some cases, operation including pump-only operation may be disabled during alarm generation.

Communications

Overview of Communications Function

This Product's Operating States and Operation Control via Communications Functionality

Operating State		Total Shutdown		Product Running		Pump-only Operation	
Communications Identifier's State	Operating State (JŌ)	0		1		2	
	Alarm signal(ER)	None	E * *	None	C * *	None	E * * or C * *
Control Plate's State	Operation lamp	Off		On		Flashing	
	Digital display	Water temperature	E * *	Water temperature	C * *	Pon	E * * or C * *
Operation Control via Communications : Control enabled × : Control disabled	Product start	ACK	× NAK	× ACK	× ACK	× NAK	× NAK
	Pump-only operation start	ACK	× NAK	× NAK	× NAK	× ACK	× ACK
	Shutdown (both for the product and the pump)	× ACK	× ACK	ACK	ACK	ACK	ACK

1 An ACK response is generated when :

This product enters the operating state specified by the executed control action (indicated by "ACK" in the table above), or when

This product is already in the state specified by the executed control action (indicated by "× ACK" in the table above).

2 An NAK response is generated when :

This product cannot enter the state specified by the executed control action.

Communications Timings

1. Delay time between data reception and transmission (of a response)

(1) Polling : about 125 ms

(2) Selecting : about 170 ms

2. Time between transmission completion and high impedance output (transmission)

(1) Polling : about 8 ms

(2) Selecting : about 8 ms

Communications

Overview of Communications Function

Communications Cables and Connectors

1. RS-232C

Applicable connectors

D sub 9-pin (Female) connector

Maximum wiring length

Within 15m.....It becomes shorter or longer depending on the use condition.

2. RS-422A (RS-485)

Applicable connectors:

Terminal block

Cable wiring diameter

AWG16 to 24

(In case of inserting two wirings into one place of terminal board, use the wirings from AWG18 to 24.)

Cable coating removal length

10mm

Cable end treatment

Peel a coating of wiring, and use it as it is.

Carry out wiring treatment in order not to touch (short-circuit) with adjacent wiring by loosening of core wiring.

Maximum wiring length

Within 100m.....becomes shorter or longer depending on the use condition.

Connection example

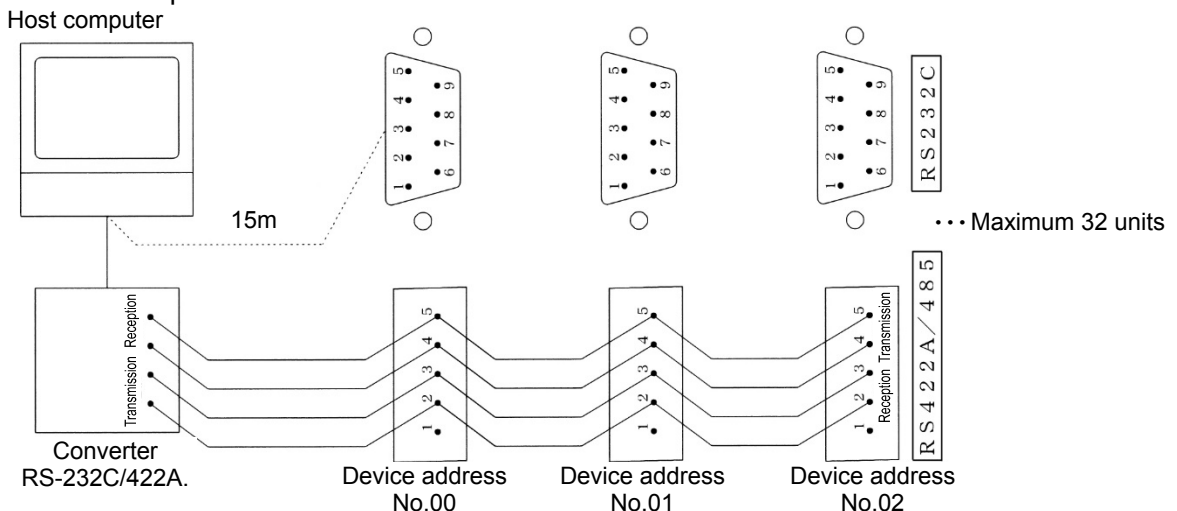

In case that the communication port of host computer is RS-232C specification, direct connection is possible. When the wiring length is over 15m, connect the commercially available converter RS-232C/422A.

Example of commercially available converter: NETWORK SUPPLY

GPNET232-485CT (body)

GP-259RS (DOS/V 9 pins connector)

SFN-830 (AC Adaptor)

Inspection and Maintenance



WARNING

Never operate switches with wet hands, and never touch electrical components. Improper handling may result in electric shock.



WARNING

Do not use water to clean this product, and do not allow water to spill onto or in the vicinity of this product. Water contact may result in fire or electric shock.



WARNING

If you open the cabinet to enable inspection or cleaning, be sure to close the cabinet when this work is finished. Never operate this product while the cabinet is open. Touching the inside of this product may result in injury or electric shock.

Always cut off the main power to the product before starting maintenance, cleaning, or inspection. Leaving the power supply connected while work is in progress may result in electric shock, burn, or other injury.



WARNING

The inverter becomes very hot while running and remains hot for a while after the power turns off. Touching it directly may cause a burn.

Keep hands clear of fins when cleaning the condenser (its filters). Touching the fin may result in injury.

IMPORTANT

In order to ensure that this product fully demonstrates its capabilities, regularly check and maintain the condenser (its filters) and the water circuit, and perform cleaning according to the soil condition. Poor maintenance may activate the safety system or cause failure in addition to lower thermal efficiency and poorer performance. The types and timings of maintenance activities are as shown below. For other required services such as adjustment and circuitry cleaning, contact local dealer in your area or service specialists qualified by Orion Machinery and enter into separate services contracts.

General Inspection Intervals

Component	Check Item	Checking Cycle			Remarks
		Daily	Monthly	Semi-annual	
Water level gauge	Check that water level in the tank is within E and F.				Regarding the checking procedure, refer to Page 10
Water pressure gauge	Check that it indicates 0.50MPa or lower.				If out of the range, refer to the "Adjusting the water feeding pressure (flow rate)" on Page 12
Condenser (filters)	Soil on filters		1		See page 42 for the checking procedure.
Water circuit	Water quality and temperature				Replace as appropriate.
Pressure pump	Leakage				The mechanical seals are inspection-time replacement parts. See page 63.
Y-shaped strainer	Soil on the mesh section				See page 43 for the checking procedure.

1 Monthly or when a "C00" caution alarm is generated.

Inspection and Maintenance

Monthly Inspection and Maintenance

Monthly Inspection and Maintenance

1. Clean the outside of the product. Use neutral detergent.
2. Clean the condenser filters.

1) Removing the filters.

Slide the filter up so that it clears the catch at the bottom.
Pull the filter down and out.

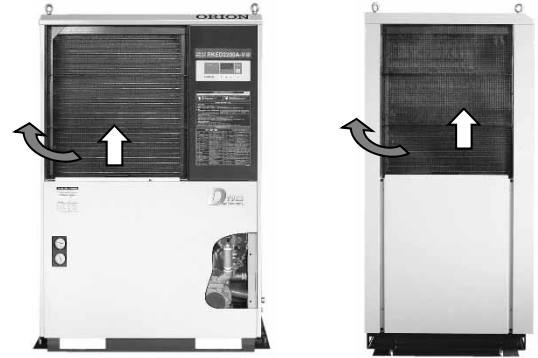

2) Cleaning the filters.

Clean with a vacuum cleaner.
If stronger cleaning is needed, wash with water and neutral detergent. Then let dry in shade.

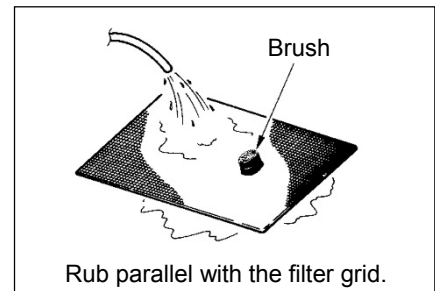
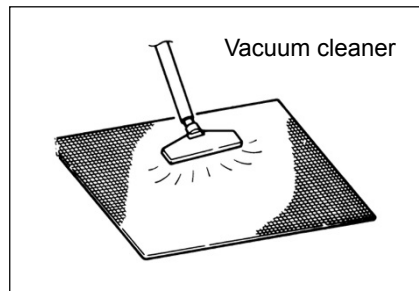

3. Clean the condenser.

Remove the condenser filters.
Clean the condenser with a long-haired brush or an air gun.

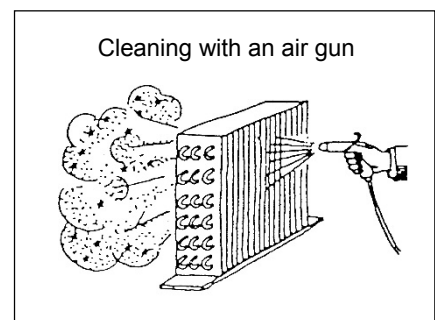
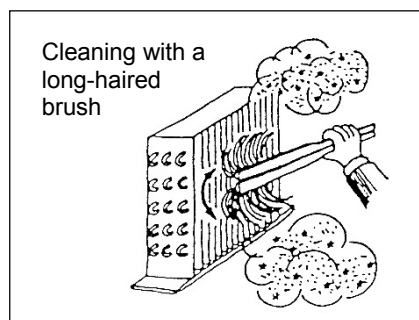

An illustration is image. A condenser can not actually be removed.

4. Clearing a "E00" 500-hour Filter Use Caution Alarm

After cleaning condenser and the filters, clear the operating-hour timer for "E00".

Clearing the "E00" operating-hour timer

Hold down the RESET switch on the control plate for 5 seconds or longer.

The digital display indicates that the clearing is completed by causing "E00" and "CLR" to blink in turn for 5 seconds. (The 500-hour counting starts at this point.)

Cleaning operation is possible while product is operating.

Inspection and Maintenance

Monthly Inspection and Maintenance

IMPORTANT

Dust accumulation on the condenser may lead to reduced heat-exchange performance. Severe accumulation may activate safety devices, causing the product to shut down.

Do not wash with boiling water or attempt to remove dirt with heat.

Do not operate the product with the condenser filters removed. Intake of dust may cause the condenser to fail.

Do not use a damaged filter. Replacement filters are available. See page 63 for ordering information.

After cleaning is completed, hold down the RESET switch for 5 seconds or longer to reset the 500-hour filter use caution alarm (E00) timer. You have successfully reset it if "E00" and "E00" start blinking in turn.

5. Check the water circuit.

Check water in the water circuit monthly in order to keep it clean and replace the water if any of the following problems are detected :

The internal wall of the water tank is sludgy when checked with fingers.

Any foreign matter is in the water tank.

Water color is abnormal.

IMPORTANT

Refer to "Water Quality Control" on page 45 for water purity.

If water becomes unusually dirty and required frequent replacement, it may be necessary to perform chemical cleaning of the water circuit. Contact local dealer in your area for assistance.

If the Y-shaped strainer mesh is blocked with dirt or other substances, resulting in a pressure difference between the inlet and outlet ports of 0.1 MPa or higher, it could result in damage to the mesh.

6. Cleaning the Y-shaped Strainer

- 1) Close the valve (customer-supplied) which is attached on the Cold Water inlet and outlet.
- 2) Remove the stopper of Y-shaped strainer, and take out the mesh.
- 3) Wash away the dirt on the mesh.
- 4) Attach the mesh to the Y-shaped strainer.
- 5) Open the valve (customer-supplied), which is attached on the Cold Water inlet and outlet.

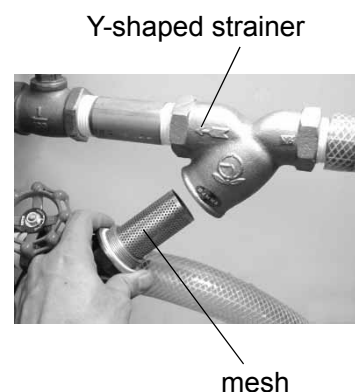

IMPORTANT

Be sure to open the valve (customer-supplied) at the Cold Water inlet and outlet before re-starting this product. Operating with the valve closed may lead to failure.

Inspection and Maintenance

Semi-Annual Inspection and Maintenance

Semi-Annual Inspection and Maintenance

1. Pressure Pump Leakage Checking

Leakage Checking

Remove the cabinet front plate. (Refer of page 49 for removing the cabinet front plate and distributing board cover)

Check for water leakage from the pressure pump's main body.

If you find a leak, contact local dealer in your area.

Mechanical seals will need to be replaced.

2. Inverter Checking (See "Major Components inside the Distributing Board" on page 50.)

Inverter fins Checking and Cleaning

With the fan inverter (U) check for dust or dirt on the fins and use an air gun to clean them if necessary.



WARNING

The inside of the inverters are electrically charged. Be sure to cut off the power and wait about 10 minutes or longer before starting inspection.

Keep off the inverters immediately after power-off; it may lead to a burn or electric shock.

IMPORTANT

If there is dust or dirt deposited on the cooling fins of the inverters, they may be unable to cool the heat-generating components inside the inverters. In an extreme case, it may cause the safety system to operate, leading to system shutdown.

Water Quality Control



1. Liquid that can be cooled by this product (Cold Water) includes fresh water (compliant with the water standards in the table below) or a low concentration industrial-use ethylene-glycol water solution with a concentration of 30 to 40%. Using any other liquid may damage the product or cause liquid leakage, electric shocks or electric leakage.

Fresh Water Quality Standard

	Item	Cold Water/Circulated Water
Basic Item	pH (25)	6.8 to 8.0
	Electrical conductivity (25) (μ S/cm)	1 to 400
	Chloride ions (mgCl ⁻ /L)	50 or less
	Sulfate ions (mgSO ₄ ²⁻ /L)	50 or less
	Acid consumption (pH4.8) (mgCaCO ₃ /L)	50 or less
	Total hardness (mgCaCO ₃ /L)	70 or less
	Calcium hardness (mgCaCO ₃ /L)	50 or less
	Ionic-state Silica (mgSiO ₂ /L)	30 or less
Reference Item	Iron (mgFe/L)	1.0 or less
	Copper (mgCu/L)	1.0 or less
	Sulfate ions (mgS ²⁻ /L)	None
	Ammonium ions (mgNH ₄ ⁺ /L)	1.0 or less
	Residual chlorine (mgCl/L)	0.3 or less
	Free chlorine (mgCO ₂ /L)	4.0 or less

Source: Refrigerating and air-conditioning water quality guidelines, JRA-GL-02-1994.

2. If any abnormality is found during a periodic inspection, clean the water tank and the water circuit and replace the water in the tank. Additionally, **replace the water in the tank once every 3 months** because water evaporates and impurity concentration becomes higher even if no abnormality is found in the inspection. For the periodic inspection procedure, see the "Inspection and Maintenance" section.

Water Quality Control

3. For trouble-preventive measures, see the table below.

Water State	Possible Trouble	Preventive Action
High concentration of solid particles (groundwater may contain an amount of sand or gravel particles.)	The evaporator may be clogged, leading to degradation of the chilling performance. In some cases, these particles could damage the evaporator and lead to a gas or water leakage.	Install Y-shaped strainers (included in the package) on the supply piping and the Cold-Water inlet piping. Additionally, if you have installed a Y-shaped strainer at the Cold Water inlet piping, check the product's water pressure gauge daily to ensure that the water pressure is less than the upper limit of the operating pressure specified for the pressure pump.
	The pressure pump's impeller and the sliding sections become prone to abnormal wear, resulting in failure.	
	The sliding sections of the pressure pump's mechanical seals are prone to uneven wear in a short period of time, leading to water leakage.	
Water contains chloride ions or other corrosive substances.	Corrosive substances such as chloride ions may corrode the stainless member in the water passage, leading to water or gas leakage. Additionally, where suspended matters such as iron rust or has deposited or where scales have been produced, corrosion may aggravate due to formation of an oxygen concentration cell, even if the concentrations of corrosive substances are below the water standard figures.	The water standards Orion specifies are designed to control chloride ions, scaling degradation and other corrosive substances. Always keep the operating liquid under control so that it is compliant with the water quality standards. Also, be sure to install Y-shaped strainers (included in the package) to prevent intrusion of iron rust and other foreign matters.
Water contains additives (such as anticorrosive and antirust chemicals).	Depending on the concentration and components, the additives used may aggravate wear on the mechanical seals' sliding sections or residual substances may deposit at the sliding sections, leading to water leakage from the mechanical seals.	Depending on the concentration and components, the additives used may shorten the mechanical seals' replacement cycle. If any additives are used, contact local dealer in your area or Orion. We can provide information that can help you determine if the additives can be safely used and the mechanical seals replacement information.
Water contains high-viscosity additives such as an antifreeze solution.	The pressure pump performance (pump head) may be degraded.	For an antifreeze solution, use industrial ethylene-glycol water solution with a concentration of 30 to 40%. As antifreeze solutions do not evaporate, replace the water in the tank periodically to prevent the water concentration from becoming higher.
	Water may leak from the pressure pump's mechanical seals. (Since viscose liquid such as an antifreeze solution does not evaporate, minor bleeding is often observed around the pressure pump's mechanical seals. Note, however, that a high concentration increases viscosity, resulting in increased liquid thickness between the sliding surfaces, which leads to an increase in leakage.)	
The pressure pump has been kept out of service for a prolonged period.	The water inside the pressure pump may degrade, the sliding surfaces of its mechanical seals may be locked, the mechanical seals may be locked when restarting the pressure pump, or water leakage may occur. (If you restart the pressure pump with the mechanical seal sliding sections locked, the sliding sections are forced to break off from each other, leading to abrasion that would cause water leakage. Additionally, possible causes of water degradation include condensing of the additives such as antifreeze solution and microorganism development.	During an extended period of non-use, drain the water tank and piping according to the procedures under the "Storing the Product" section of the operation manual. Next, fill the tank with clean water and run the pressure pump in pump-only mode for ten minutes or longer, drain the tank again, and then store the product.
Tap water is always supplied.	If tap water is constantly supplied (along a single-path), residual chloride may corrode the evaporator if its concentration is high, leading to gas leakage.	Do not use a product with a water tank in one-path mode.

Mechanical Seal

It is considered that the mechanical seal does not generally leak out. However, it is impossible to lose a leak completely in structure, and it is designed to occur a very small amount of leak. (The mechanical seal is damaged from the generation of heat in a short term when the leakage is completely stopped.) Quantity of this leak is prescribed with less than [3cc/hr] in JIS, but usually regards a leak of 0.05 to 0.15cc/hr in the mechanical seal of a general-purpose pump. This value evaporates in the case of spring water, and it cannot confirm by viewing. However, the leak quantity needs periodical replacement to increase with progress of operation time.

In addition, the target of periodical replacement of the mechanical seal when it was used is for 6000 to 8000 hours or one year in the Orion's specified water standard.

Diagnosing and Troubleshooting Unit Failure or Abnormalities

Alarm Types and Product's Actions



WARNING

- If the product behaves abnormally, switch it off and then cut the power. Then please contact local dealer in your area or service specialists qualified by Orion Machinery. Continuing to run the product while operation is abnormal may result in fire or electric shock.
- Be sure to replace the cabinet to its original location after completing necessary actions and resetting of the safety system. Never operate this product while the cabinet is open. Touching the inside of this product may result in injury or electric shock.
- Be sure to cut the power to the product before taking corrective actions or resetting any of the safety devices. Leaving power on may result in electric shock or in injury from the fan.

Alarm Types and Product's Actions

Alarm Handling List

Alarm Number	Name	Alarm Handling Pattern	Operating Signal	Alarm Signal	Display	Restore
C00	500-hour Filter Use Caution Alarm	1	○	×	Alternate displays	Manual
E02	High Pressure Switch, Fan Inverter (U) Alarm	2(3)	×	○	Alternate displays	Manual
E03	Compressor 1 Over Current Relay Alarm	5(3)	×	○	Alternate displays	Manual
E05	Pressure pump Over Current relay, or fuse that is inside of the control plate is blowout	3	×	○	Alternate displays	Manual
E06	Lower Water Alarm	3	×	○	Alternate displays	Manual
C07	Upper/Lower Water Temperature Limit Alarm	1	○	○	Alternate displays	Auto
E09	Power Phase Loss, or fuse that is inside of the control plate is blowout	3	×	○	Blinking	Power-on
E10	Power Phase Reversal	3	×	○	Blinking	Power-on
E11	Water Temperature Sensor Failure (measurement temperature low)	3	×	○	Blinking	Manual
E12	Water Temperature Sensor Failure (measurement temperature high)	3	×	○	Blinking	Manual
E13	Memory Error	3	×	○	Blinking	Power-on
E14	Power Suspension Recovery	3	×	○	Alternate displays	Manual
E15	Other Error	3	×	○	Blinking	Manual
C21	Distributing Board Temperature Caution Alarm	1	○	×	Alternate displays	Auto
E21	Distributing Board Temperature Error Alarm	2(3)	×	○	Alternate displays	Manual
E41	Discharge Pressure Operation Error (protective control limit)	2(3)	×	○	Alternate displays	Manual
E42	Discharge Pressure Error (protective control disabled)	2(3)	×	○	Alternate displays	Manual
E43	Discharge Temperature Operation Error (protective control limit)	2(3)	×	○	Alternate displays	Manual
E44	Discharge Temperature Error (protective control disabled)	2(3)	×	○	Alternate displays	Manual
E45	Superheat Drop Failure	2(3)	×	○	Alternate displays	Manual
E47	Discharge Temperature Sensor Failure (measurement temperature low)	2(3)	×	○	Alternate displays	Manual
E48	Discharge Temperature Sensor Failure (measurement temperature high)	2(3)	×	○	Alternate displays	Manual
E49	Suction Temperature Sensor Failure (measurement temperature low)	2(3)	×	○	Alternate displays	Manual
E50	Suction Temperature Sensor Failure (measurement temperature high)	2(3)	×	○	Alternate displays	Manual
E53	Discharge Pressure Sensor Failure (measurement pressure low)	2(3)	×	○	Alternate displays	Manual
E54	Discharge Pressure Sensor Failure (measurement pressure high)	2(3)	×	○	Alternate displays	Manual
E55	Suction Pressure Sensor Failure (measurement pressure low)	2(3)	×	○	Alternate displays	Manual
E56	Suction Pressure Sensor Failure (measurement pressure high)	2(3)	×	○	Alternate displays	Manual
E58	DIP Switch Setting Error	3	×	○	Blinking	Power-on
E61	Discharge/Suction Pressure Sensor Failure	2(3)	×	○	Alternate displays	Manual
E62	Discharge/Suction Temperature Sensor Failure	2(3)	×	○	Alternate displays	Manual
C64	Differential Pressure Start-up Stand-by	2	○	×	Alternate displays	Auto
C65	Shutdown Caution Alarm	3	×	×	Alternate displays	Auto
E70	Compressor 2 Over Current Relay Alarm	4(3)	×	○	Alternate displays	Manual

Diagnosing and Troubleshooting Unit Failure or Abnormalities

Alarm Types and Product's Actions

Notations in parentheses for alarm handling patterns and operating signals represent results when "0" is selected to the F4 parameter.

The symbol () for signals indicates that a signal is output, and the symbol x, that no signal is output.

The operating signal and an alarm signal behaviors represent the cases where the respective alarm is generated by itself.

Even with an alarm that sustains a signal generation, the operating signal is suspended if other alarms are generated in conjunction and the compressor shuts down.

"Alternate display" in the Display column indicates that the water temperature measurement and the alarm number are displayed in turn. "Blinking" indicates that the relevant alarm number blinks.

E14 only outputs a signal when "0" (default) is selected for the F1 parameter.

Actions in Response to Alarms

Alarm Handling Pattern	Compressor 1 Operation	Compressor 2 Operation	Fan Operation	Pressure Pump Operation
1				
2	x ()	x ()	x ()	
3	x	x	x	x
4		x		
5	x			

The symbol () indicates continuous operation, and the symbol x indicates suspension of operation.

The symbol () indicates the alarm 64. Operation will resume after a set time.

The indication x has preference in case more than one alarm of different alarm handling patterns are generated concurrently.

Example) In case of generating the alarm-handling patterns 2 and 3, the product becomes OFF completely.

Diagnosing and Troubleshooting Unit Failure or Abnormalities

Equipment Location

Equipment Location



WARNING

Be sure to remount the cabinet plate(s) after resetting safety devices or taking other corrective action. Never operate the product while the cabinet is open. Touching the inside of the product may result in injury or electric shock.

If the product behaves abnormally, switch it off and then cut the power. Then please contact local dealer in your area or service specialists qualified by Orion Machinery. Continuing to run the product while operation is abnormal may result in fire or electric shock.

Be sure to cut the power to the product before taking corrective actions or resetting any of the safety devices. Leaving power on may result in electric shock or in injury from the fan.



CAUTION

Be sure to wear gloves before removing the cabinet or checking its inside.

The metal plate edges may cause an injury.

Avoid contacting the internal section of this product carelessly. Some sections (the compressor and piping) are very hot and may cause a burn.

Removing the Cabinet Front Plate and Distributing Board Cover

Loosen the screw holding the cabinet front plate in place.

Lean the cabinet front plate out (from the top), and lift it up and off.

Remove the fixing screws on the distributing board cover.

Pull the distributing board cover forward to remove it by pulling it up at angle.

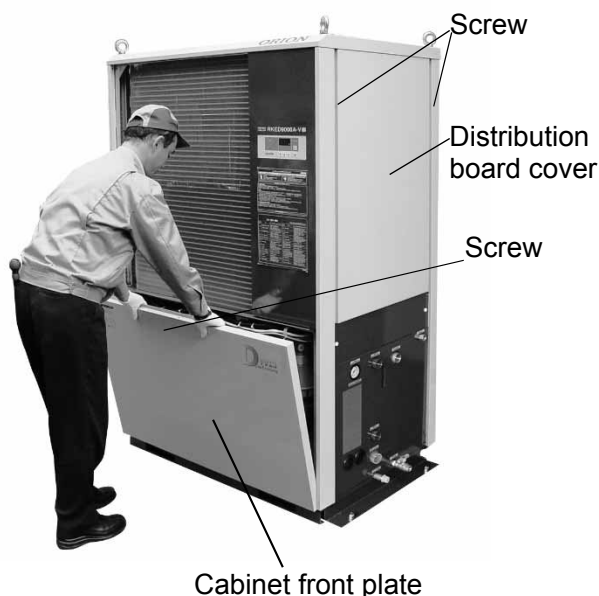

Diagnosing and Troubleshooting Unit Failure or Abnormalities

Equipment Location

Major Components

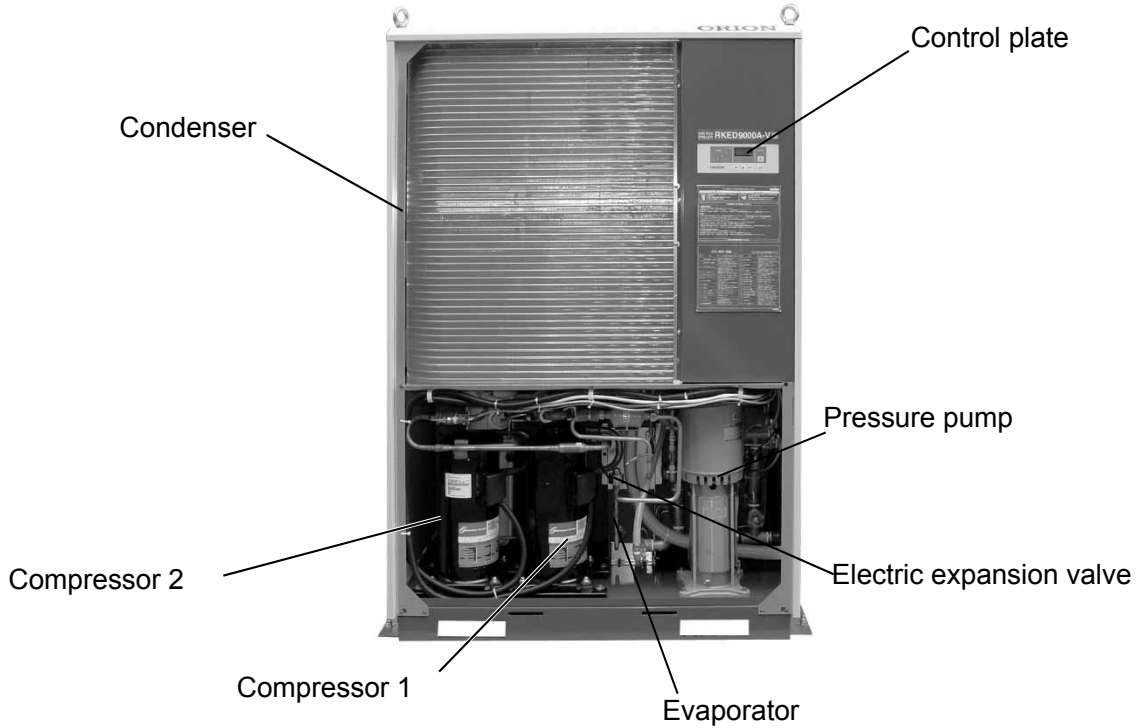

Major Components inside the Distributing Board

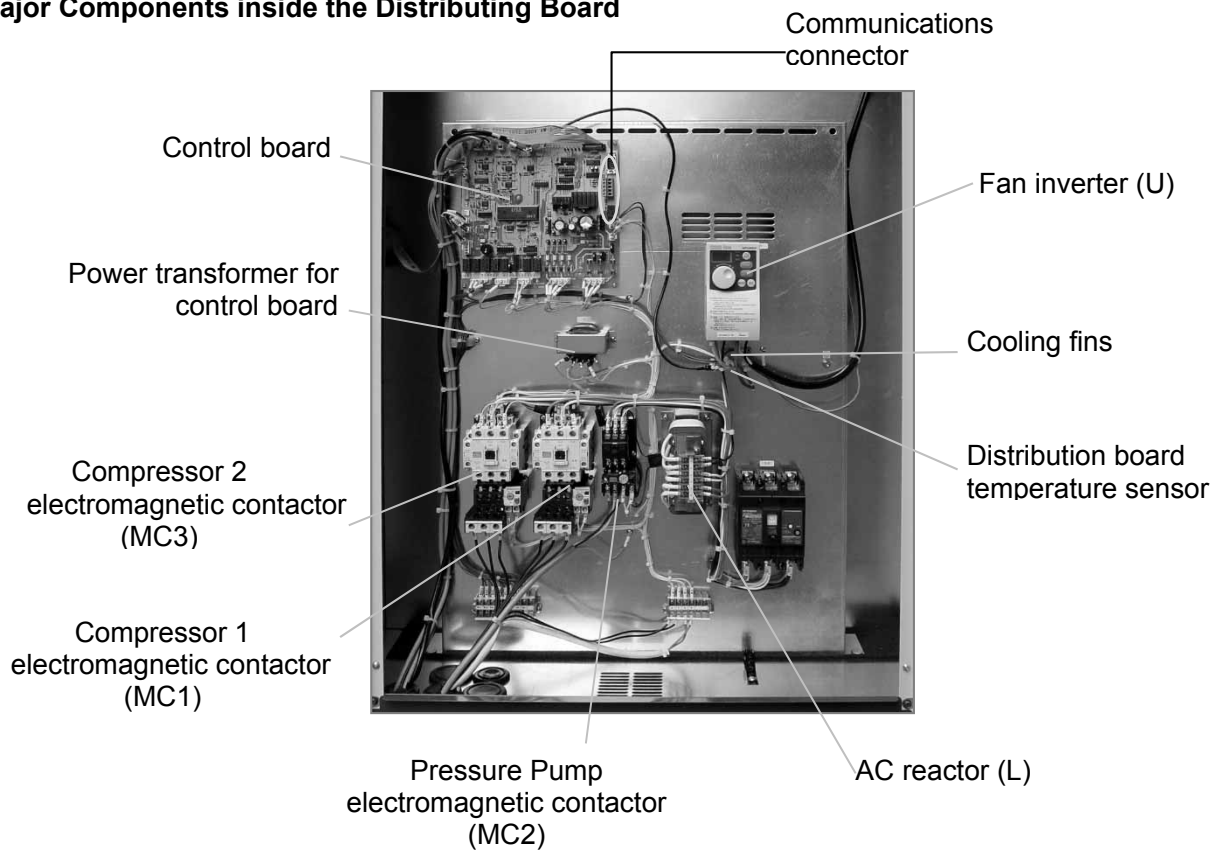

Diagnosing and Troubleshooting Unit Failure or Abnormalities

Alarm Causes and Corrective Actions

Alarm Causes and Corrective Actions

"C00" 500-hour Filter Use Caution Alarm

<Cause>

The operating hours have exceeded 500 hours.

<Action>

Clean the condenser (filters) following the procedure on page 42.

<Clearing the alarm>

Hold down the RESET switch on the control plate for 5 seconds or longer to clear the alarm.
(Clearing is available during operation.)

E02 High-Pressure Switch, Fan Inverter (U) Alarm

<Cause>

- (1) The fan inverter (U) alarm was generated.
- (2) The refrigerant discharge pressure has increased excessively, causing the high-pressure switch (HPRS) to operate.

<Action>

- (1) Take corrective actions according to the instructions stated below in response to the display that appears on the fan inverter (U) inside the distributing board as shown in codes below.

Key sheet displayed	Protection function name	Protection function details	Recovery
OC1 (OC1)	Over-current shut-down	Abnormality with the inverter's output current	<ul style="list-style-type: none"> • Check the power supply voltage. • Contact local dealer in your area.
OC2 (OC2)			
OC3 (OC3)			
OV1 (OV1)	Over-voltage shut-down	Abnormality with the inverter's direct-current voltage	<ul style="list-style-type: none"> • Check the power supply voltage. • If there is no abnormality with the voltage, it is being affected by excessive electrical noise. • Contact local dealer in your area.
OV2 (OV2)			
OV3 (OV3)			
THM (THM)	Overload shut-down (electrical thermal)	Overloading, overheating or over-current in the fan motor	<ul style="list-style-type: none"> • Check the power supply voltage. • Check for any foreign matter or locking • Contact local dealer in your area.
THT (THT)			
Fin (FIN)	Fin overheating	Inverter overheating	<ul style="list-style-type: none"> • Clean the inverter's cooling fins. • Control the ambient temperature within the specified range.
PE (PE)	Abnormal parameter	Abnormality exists with the parameter	<ul style="list-style-type: none"> • Contact local dealer in your area.
CPU (CPU)	CPU error	CPR failure	<ul style="list-style-type: none"> • Contact local dealer in your area.

- (2) If no code as shown above is displayed on the fan inverter (U) device, the HPRS high-pressure switch is operating. Follow the instructions on page 42 to clean the condenser (filters) and lower the ambient temperature.

Diagnosing and Troubleshooting Unit Failure or Abnormalities

Alarm Causes and Corrective Actions

<Clearing the alarm>

(1) Fan Inverter (U) Alarm :

Resetting the inverter unit

Turn off and on the main power or press the RESET switch on fan inverter (U).

Resetting this product

If you have pressed the RESET switch on fan inverter (U), pressing the RESET switch on the control plate to reset this product. (Turn on the power again to automatically reset the product.)

(2) High-Pressure Switch

Press the RESET switch on the control plate or cut off the main power of this product once and then turn on the power again. (You cannot clear the alarm unless the discharge pressure goes down to 2.35 MPa or lower.)

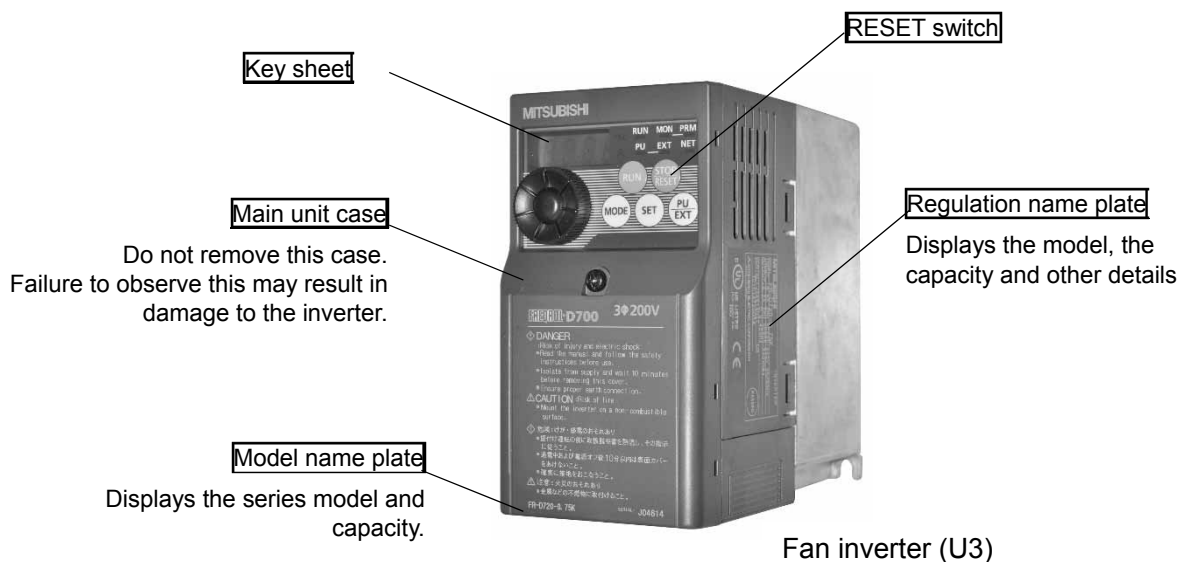

E03 Compressor 1 Overcurrent Relay Alarm.

<Cause>

Overcurrent from the compressor 1 may have started. the overcurrent relay (THR1) worked.

<Action>

- (1) Check that power supply and voltage is to the specification.
- (2) Check the compressor is not locked.

<Clearing the alarm>

Cut off the power for this product and press the RESET switch for overcurrent relay (THR1) inside the distributing board, and then turn on the power again.

Diagnosing and Troubleshooting Unit Failure or Abnormalities

Alarm Causes and Corrective Actions

E05 Pressure Pump Overcurrent Relay, or fuse that is inside of the control plate is blowout

<Cause>

Overcurrent from the pressure pump may have started the overcurrent relay (THR2) or blown the fuse inside the control board (R-phase fuse).

<Action>

- (1) Check that the power supply voltage is to the specification.
- (2) Check for foreign matters inside the pump and if the pump is not locked.
- (3) If fuse has blown, please contact local dealer in your area for replacement.

<Clearing the alarm>

Cut off the power for this product and press the RESET switch for overcurrent (THR2) inside the distributing board, and then turn on the power again.

E06 Low Water Alarm

<Cause>

A drop of the water level in the tank has started the float switch (FLTS).

<Action>

Check the water level in the tank and supply water.

<Clearing the alarm>

After recovering the correct water level, press the RESET switch on the control plate. Alternatively, turn off and on the main power.

C07 Upper/Lower Liquid Temperature Limit Alarm

<Cause>

The water temperature is outside the specified range. (It is set with the F20 to F23 parameters.)

<Action>

- (1) If the water temperature does not go down to the specified range
The cooling performance may be under par due to clogging of the condenser (filters) or an excessively high ambient temperature.
Clean the condenser (filters) and lower the ambient temperature.
Check that the thermal load is within a range that can be handled by this product's cooling capacity.
- (2) If the water temperature is too low
The water temperature may become as low as about -1.5 on the temperature setting when a thermal load is suddenly eliminated or when it becomes very low.
It is not abnormal if the temperature increases to the water temperature setting again.

<Clearing the alarm>

This alarm is automatically cleared when the water temperature recovers the value within the specified range.

E09 Power Phase Loss, or fuse that is inside of the control plate is blowout

<Cause>

A phase loss may have occurred on the main power for this product, or the fuses (R-, S- and T-phase fuses) inside the distributing board may have blown.

<Action>

- (1) Cut off the main power for this product and check connections.
- (2) If any fuse is blown, please contact local dealer in your area for replacement.

<Clearing the alarm>

Turn on the main power again.

Diagnosing and Troubleshooting Unit Failure or Abnormalities

Alarm Causes and Corrective Actions

E10 Power Phase Reversal

<Cause>

The phases of the main power are reversed.

<Action>

Cut off the main power and switch connections for 2 out of the 3 phases. (see “ wiring work ” on page 76.)

<Clearing the alarm>

Turn on the main power again.

E11 Liquid Temperature Sensor Failure (measurement temperature low)

<Cause>

The water temperature measurement is less than 15 °C, or the water temperature sensor is disconnected.

<Action>

(1) Check if any section of this product's internal piping is frozen. Start the pump-only operation and completely open the water circuit. After this step, if the water pressure is 0.50 MPa or higher, or if the water pressure gauge does not operate, then freeze-up has occurred. Check if decreased the pressure pump flow rate or the ambient temperature has been outside the specified range and correct the condition if necessary. To restart the product, first perform the pump-only operation, and check that the water flows at an adequate rate.

(2) If no freeze-up has occurred, the water temperature sensor is disconnected.

Please contact local dealer in your area.

<Clearing the alarm>

When the water temperature measurement display becomes -15 °C or higher, press the RESET switch on the control plate or turn off and on the main power for this product.

E12 Liquid Temperature Sensor Failure (measurement temperature high)

<Cause>

The water temperature measurement is higher than 50 °C, or the water temperature sensor is short-circuited.

<Action>

(1) If the actual water temperature is higher than 50 °C, check the following items and takes measures to increase the water temperature such as replacing the water in the tank.

The cooling performance may be under par due to clogging of the condenser (filters) or an excessively high ambient temperature.

Clean the condenser (filters) and lower the ambient temperature.

Check that the thermal load is within the range that can be handled by this product's cooling capacity.

(2) If the actual water temperature is 50 °C or lower when the E12 alarm is generated, the temperature sensor is short-circuited. Please contact local dealer in your area.

<Clearing the alarm>

If the water temperature sensor is operating normally, press the RESET switch on the control plate or turn off and on the main power.

Diagnosing and Troubleshooting Unit Failure or Abnormalities

Alarm Causes and Corrective Actions

E13 Memory Error

<Cause>

The contents of the memory on the control board are incorrect.

<Action>

- (1) Press the RESET switch on the control plate.
- (2) Turn off and on the main power for this product.

<Clearing the alarm>

If the abnormality has been corrected when you turn on the power again, then this product will restart automatically.

To Restore Memory to Factory Defaults

IMPORTANT

For special built products, be sure to check with your dealer before restoring the memory to its default settings. The contents of special settings may be cleared by the resetting the memory to factory defaults.

1. Turn off the power supply of the product once.
2. Turn on the power supply while pressing the “temperature adjustment switch ()” and the “SET switch” of the control plate at the same time.
3. Stop pressing the switches when the buzzer sounds and [E L -] is blinked on the digital display.
4. Press the “SET” switch to default the memory. (In order to back out of the reset operation, press any button other than the “SET” switch.
5. “HELLO CHILLER 888” is displayed on the digital display, and the memory reset to factory defaults is complete.
6. Be sure to once again set parameters that are required but were lost during the memory restore operation. (Refer to P22.)

E14 Power Suspension Recovery

<Cause>

Power suspension occurred while this product is running.

This alarm is only output when the F1 parameter is set to "0" (default).

<Action>

To automatically restart the product upon power recovery, change the F1 parameter setting according to the instructions on page 22.

<Clearing the alarm>

Press the RESET switch in the control plate to clear the alarm. To restart, press ON/OFF switch.

Diagnosing and Troubleshooting Unit Failure or Abnormalities

Alarm Causes and Corrective Actions

E15 Other Error

<Cause>

- (1) Noise may be present or inductive matters such as metal particles have intruded onto the control board.
- (2) Power supply is unstable.

<Action>

- (1) Check for a noise source in the vicinity and foreign matters settled on the control board.
- (2) Check that the main power is not prone to a temporary power suspension or a voltage drop below the specified level.

<Clearing the alarm>

After eliminating the cause, press the RESET switch on the control plate or turn off and on the power.

C21 Distributing Board Temperature Caution Alarm

<Cause>

The temperature of the inside of the distributing board is higher than 50 °C.

<Action>

- (1) Set the ambient temperature within the allowable range.
- (2) Improve the situation if the product comes in contact with direct sunlight.

<Clearing the alarm>

This alarm is automatically cleared when the distributing board's internal temperature falls 50 °C or lower.

E21 Distributing Board Temperature Error Alarm

<Cause>

- (1) The temperature inside of the distributing board is higher than 55 °C, or the distributing board temperature sensor is short-circuited.
- (2) The temperature inside of the distributing board is less than -15 °C, or the distributing board temperature sensor is disconnected.

<Action>

- (1) Control the ambient temperature within the range of -5 to 43 °C.
- (2) Improve the situation if the product is exposed to direct sunlight.
- (3) Using the monitoring function described on page 21, display the distributing board temperature to compare it with the actual. If it differs significantly from the actual, the distributing board temperature sensor is short-circuited or disconnected. Please contact local dealer in your area.

<Clearing the alarm>

After the distributing board's internal temperature is between -15 and 55 °C, press the RESET switch on the control plate, or turn off and on the main power.

Diagnosing and Troubleshooting Unit Failure or Abnormalities

Alarm Causes and Corrective Actions

E41 Discharge Pressure Operation Error (protective control limit)

<Cause>

Protective control could not lower the refrigerant discharge pressure or the compressor current, completely disabling control over the compressor 1 operating frequency.

<Action>

- (1) Clean the condenser (filters) and set the ambient temperature within the allowable range.
- (2) Check that the power supply voltage has not dropped.

<Clearing the alarm>

Press the RESET switch on the control plate, or turn off and on the main power.

E42 Discharge Pressure Error (protective control disabled)

<Cause>

Protective control execution was not timely, resulting in an abnormal increase of the refrigerant discharge pressure.

<Action>

Check that the ambient temperature has not abruptly increased and if the condenser filters are not soiled with foreign matters.

<Clearing the alarm>

Press the RESET switch on the control plate, or turn off and on the main power.

E43 Discharge Temperature Operation Error (protective control limit)

<Cause>

Protective control could not lower the refrigerant discharge temperature, completely disabling control over the compressor 1 operating frequency.

<Action>

Clean the condenser (filters) and set the ambient temperature within the allowable range.

<Clearing the alarm>

Press the RESET switch on the control plate, or turn off and on the main power.

E44 Discharge Temperature Error (protective control disabled)

<Cause>

Protective control execution was not timely, resulting in an abnormal increase of the refrigerant discharge temperature.

<Action>

Check that the ambient temperature has not abruptly increased and if the condenser filters are not soiled with foreign matters.

<Clearing the alarm>

Press the RESET switch on the control plate, or turn off and on the main power.

Diagnosing and Troubleshooting Unit Failure or Abnormalities

Alarm Causes and Corrective Actions

E45 Superheat Drop Failure

<Cause>

- (1) Heat exchange is not performed normally on the evaporator.
- (2) The electric expansion valve is not work properly.

<Action>

- (1) Check that decreased the pressure pump flow rate or the ambient temperature has been outside the specified range.
- (2) When turning on the main power for this product, check if the electric expansion valve generates clicking sounds. If not, the electric expansion valve is faulty. Please contact local dealer in your area.

<Clearing the alarm>

Press the RESET switch on the control plate, or turn off and on the main power.

E47/E48 Discharge Temperature Sensor Failure

<Cause>

- (1) The discharge temperature sensor is disconnected. (E47)
- (2) The discharge temperature sensor is short-circuited. (E48)

<Action>

The discharge temperature sensor needs to be replaced. Please contact local dealer in your area.

<Clearing the alarm>

Press the RESET switch on the control plate, or turn off and on the main power (if the sensor failure has been corrected).

E49 Suction Temperature Sensor Failure (measurement temperature low)

<Cause>

The refrigerant suction temperature has dropped to lower than -20 °C, or the suction temperature sensor is disconnected.

<Actions>

- (1) Check that the evaporator is not frozen. Start the pump-only operation and completely open the water circuit. After this action, if the water pressure is 0.50 MPa or higher, or if the water pressure gauge does not operate, then freeze-up has occurred. Check if the pressure pump flow rate or the ambient temperature has been outside the specified range and correct the condition if necessary. To restart the product, first perform pump-only operation, and check that water flows at an adequate rate.
- (2) Following the instructions described on page 21, display the suction temperature to compare it with the actual. If it differs greatly from the actual, the suction temperature sensor is disconnected. Please contact local dealer in your area.

<Clearing the alarm>

Press the RESET switch on the control plate, or turn off and on the main power after the suction temperature becomes -20 °C or higher.

Diagnosing and Troubleshooting Unit Failure or Abnormalities

Alarm Causes and Corrective Actions

E50 Suction Temperature Sensor Failure (measurement temperature high)

<Cause>

The refrigerant suction temperature sensor is short-circuited.

<Action>

The suction temperature sensor needs to be replaced. Please contact local dealer in your area.

<Clearing the alarm>

Press the RESET switch on the control plate, or turn off and on the main power (if the sensor failure has been corrected).

E53/E54 Discharge Pressure Sensor Failure

<Cause>

- (1) The refrigerant discharge pressure sensor is disconnected. (E53)
- (2) The refrigerant discharge pressure sensor is short-circuited. (E54)

<Action>

The discharge pressure sensor needs to be replaced. Please contact local dealer in your area.

<Clearing the alarm>

Press the RESET switch on the control plate, or turn off and on the main power (if the sensor failure has been corrected).

E55 Suction Pressure Sensor Failure (measurement pressure low)

<Cause>

The refrigerant suction pressure is zero MPa, or the sensor is disconnected.

<Action>

- (1) If the suction and discharge pressures are both close to zero MPa when the compressor 1 is not operating, refrigerant leakage may be occurring. Follow the instructions on page 21 for checking the pressures.
If this is the case, please contact local dealer in your area.
- (2) When turning on the main power for this product, check if the electric expansion valve generates clicking sounds. If not, the electric expansion valve is faulty. Please contact local dealer in your area.
- (3) Check that the ambient temperature is not below the specified range.
See page 5 for the operating ambient temperature range for this product.
- (4) Check that the evaporator is not frozen. Start the pump-only operation and completely open the water circuit. After this action, if the water pressure is 0.50 MPa or higher, or if the water pressure gauge does not operate, then freeze-up has occurred. Check that decreased the pressure pump flow rate or the ambient temperature has been outside the specified range and correct the condition if necessary. To restart the product, first perform pump-only operation, and check that water flows at an adequate rate.
- (5) For cases other than the above, the suction pressure sensor is disconnected. Please contact local dealer in your area.

<Clearing the alarm>

Press the RESET switch on the control plate, or turn off and on the main power after the intake pressure becomes higher than zero MPa.

Diagnosing and Troubleshooting Unit Failure or Abnormalities

Alarm Causes and Corrective Actions

E56 Suction Pressure Sensor Failure (measurement pressure high)

<Cause>

The refrigerant suction pressure sensor is short-circuited.

<Action>

The suction pressure sensor needs to be replaced. Please contact local dealer in your area.

<Clearing the alarm>

Press the RESET switch on the control plate, or turn off and on the main power (if the sensor failure has been corrected).

E58 DIP Switch Setting Error

<Cause>

- (1) On the control board, the DIP switch reading is disabled due to noise or other causes.
- (2) The DIP switch setting is incorrect.

<Action>

Turn off and on the main power for this product. If this alarm is generated again, please contact local dealer in your area.

<Clearing the alarm>

Turning on the main power for this product automatically clears this alarm if the cause has been corrected.

E61/E62 Discharge/Suction Pressure/Temperature Sensor Error

<Cause>

The respective sensors are connected incorrectly. (after replacing sensors for repair.)

<Action>

Cut off the main power for this product, and then check and correct the relevant connections.

<Clearing the alarm>

After correcting connections, turn on the main power. If this alarm is generated again, please contact local dealer in your area.

C64 Differential Pressure Start-up Stand-by

<Cause>

At start-up of the compressor 1, the difference between the refrigerant discharge and suction pressures is 0.30 MPa or greater.

<Action>

Simply wait until the pressure difference is reduced to less than 0.30 MPa. The compressor automatically starts running.

<Clearing the alarm>

This alarm is automatically cleared when the compressor starts running.

Diagnosing and Troubleshooting Unit Failure or Abnormalities

Alarm Causes and Corrective Actions

C65 Shutdown Caution Alarm

<Cause>

You have shut down the product within 3 minutes after start-up.

<Action>

When you want to shut down this product, be sure to let 3 minutes or more elapse after start-up.

<Clearing the alarm>

The system automatically clears this alarm after displaying "C65" for about 5 seconds.

IMPORTANT

For this product, always keep a 3 minutes interval between start-up and shutdown operations.

Frequent start-up and shutdown operations may result in a failure.

E70 Compressor 2 Overcurrent Relay Alarm

<Cause>

Overcurrent from the compressor 2 may have started the overcurrent relay (THR3).

<Action>

(1) Check the power supply voltage is to the specification.

(2) Check the compressor is unlocked.

<Clearing the alarm>

Cut off the power for this product and press the RESET switch for overcurrent relay (THR3) inside the distributing board, and then on the power again.

Storing the Product (Preparing for winter or for other extended period of non-use)

1. Cut off the power.

Switch off the main power.

2. Freeze-up Preventive Measures

Perform the following actions to prevent freeze-up.

Checking Water in the Tank

Before an extended non-use period starts, check the water in the tank to make sure it is clean by following the procedure for check the water circuit on page 43. If the water is unclean, replace all the water and perform the pump-only operation for 10 minutes or longer. After that, drain all the water inside this product by following the procedure below.

IMPORTANT

Storing this product for a long time without checking the water in the tank or draining the system may cause water leakage due to fixation of the pressure pump's mechanical seals or breakage resulting from freeze-up. (See "Water Quality Control " on page 45.)

Draining

- (1) Completely open the water tank drain () and the bypass valve () to drain the water tank and the piping.
- (2) Remove the pressure pump drain plug (shown in the figure below) to drain the pressure pump.



Open  Close

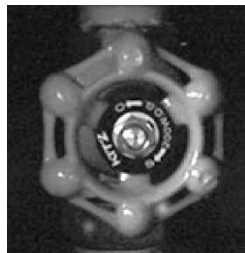

Bypass Valve



Water tank drain
Drain pan drain

[Draining the Pressure Pump]

- a. Remove the cabinet front plate.
- b. Remove the drain plug from the pressure pump and drain the pump.

3. Cover the product with a vinyl bag or similar material to protect it from dust.

4. When ready to resume usage...

Before resuming use, look over the product carefully and confirm that everything appears normal. Then start up operation as described in the "Operating Procedures" section (starting on page 9).



Drain plug

Expendable Parts

Check and Replacement Parts List / Maintenance intervals of the main parts

Check and Replacement Parts List (parts to be checked and replaced depending on wear condition)

	Part number	Part name	Piece/ unit	Check time	Replacement judgment standard
1	03090471070	Filter(front)	1	Every 1 month	Presence of damaged or broken portion
2	03090471080	Filter(side)	1		
3	0A002269000	Mechanical seal replacement set	1	Every 6 months	Leakage of 3cc/hour or more, after using for 8,000 hours ()
4	62022200250	Filtering net for Y-shaped strainer	1	Every 1 month	Presence of damaged or broken portion

Times represent rough indication values to be reviewed considering application conditions (including ambient temperature and environment surrounding the product).

Times assume the operating condition of 10 hours / day or 2,500 hours / year without frequent starts and stops (referring to the industrial air conditioner standard defined by the Japan Refrigeration And Air Conditioning Industry Association).

Main Component Maintenance Cycles

Approximate replacement times. (Actual replacement time will depend on particular operating conditions and environment.)

Maintenance intervals of the main parts

Approximate interval time when it becomes necessary to replace the parts depending on the using conditions

	Part number	Part name	Piece/ unit	Replacement time
1	04103658020	Inverter assembly	1	25,000hours
2	0A001063030	Compressor	1	20,000hours
3	0A003084000	Fan motor	1	20,000hours
4	03A30841040	Pump	1	20,000hours
5	0A001993000	Electronic expansion valve(main body)	1	20,000hours
6	0A001996000	Electronic expansion valve coil	1	20,000hours

The indicated interval time is the time when the possibility of reaching the wear failure occurrence range becomes higher. Since the aforementioned interval time may defer depending on the installation environments, it may not be always necessary to replace the subject parts when the interval time has come. However, after the replacement time passed, and there is failure when checking, replace or repair the subject parts.

Times assume the operating condition of 10 hours/day or 2,500 hours / year without frequent starts and stops (referring to the industrial air conditioner standard defined by the Japan Refrigeration And Air Conditioning Industry Association).

- Check the integrated running hour according to "Displaying Refrigerator State" on page 21, and record it in "Check List" on page 83 at each maintenance so that you can refer for the next maintenance.

Disposal

Unit Disposal

Unit Disposal

When disposing of this unit, always follow local disposal regulations and employ a professional industrial waste company for proper disposal.

After-Sales Service

■ Warranty

- The product warranty is printed at the end of this manual. Be sure to keep it in a safe place.
- Note that the user may have to pay for consumable parts even during the warranty period. Please read the warranty carefully.
- The customer will be responsible for charges incurred for repairs conducted after the warranty period has expired. Purchase of a new unit may be recommended depending on the area where the repair is to take place, as well as the particulars of the repair and the amount of time the unit has been in service, in which case, we ask that you please consult with your dealer.

■ Before Requesting Inspection or Service...

- See page 47, "Diagnosing and Troubleshooting Unit Failure or Abnormalities".
- If the problem cannot be remedied by taking the noted suggestions, do not attempt to fix the problem yourself; please consult with the dealer where the unit was purchased.

■ Spare Parts

- Spare parts are items necessary to maintain the proper function of the unit.
- Spare parts for this unit will be made available for a period of 7 years from the last day of production of the unit.

■ Requesting After-sales Service

- When requesting inspection or repairs, please provide the following information to the dealer where the unit was purchased.
 - (1) Product name
 - (2) Model designation (shown on nameplate)
 - (3) Condition (be as specific as possible)
 - (4) Address, phone number
- When ordering replacement parts, please give the following information.
 - (1) Product name
 - (2) Model designation
 - (3) Part number and quantity required

Options

Options (Sold separately)

Options (Sold separately)

Options List

	Part No.	Part name	Pieces/Unit	Remarks
1	04091273010	Communications software	1	• For details, see the "Overview of the Communications Function" on page 30.
2	03091230010	Windshield Plate Set	1	• For details, see the column of the "Contents of Each Windshield Plate Set" table. • Use the set for a product installed where the wind velocity is 8 m/s or greater.
3	03091238020	Snow Protection Hood Set	1	• For details, see the column of the "Contents of Each Snow Protection Hood Set" table. • Use the set for a product installed where snow is expected to cover the exhaust located at the upper section of this product."
4	04100608010	Remote control set B	1	• For details, see the column of the "Contents of Remote Control Set B" table. • Remote control code is necessary for connecting the remote control with the product. As for the remote control code, choose and order from the 3 different kinds of length depending on your application.
5	04100541010	Remote control code (20m)	1	
6	04100541020	Remote control code (50m)	1	
7	04100542030	Remote control code (100m)	1	
8	0A002242010	Chiller vibration isolator base	1	

Cautions :

- (1) All rights reserved. No one is allowed to copy or transfer all or part of this software or its operation manual without permission.
- (2) This software is carefully developed to eliminate errors. However, we would appreciate if you would excuse and inform us of any incorrect statements that you might find in it.
- (3) We shall not be liable for any results of using this software in any matter whatsoever.

Contents of Each Windshield Plate Set

	Part No.	Part name	Pieces/Set
1	03091236010	Windshield plate 1 Set (for the front side)	1
2	03091237010	Windshield plate 2 Set (for the left side)	1
3	03091376010	Hood fittings	1
4	03091376020	Hood fittings	1
5		Hexagonal Bolt M4 x 12	4

Contents of Each Snow Protection Hood Set

	Part No.	Part name	Pieces/Set
1	03091251010	Flange Set	1
2	03091252010	Duct 1 Set (right)	1
3	03091252020	Duct 1 Set (left)	1
4	03091253010	Duct 2	1
5		Pan-head Screw (SUS304) M5 x 12	21 (including two spare parts)
6		Truss Tap-in Screw (SUS410) M4 x 12	11 (including two spare parts)
7		Thermal Insulation (15 x 595 x t3)	4

Options

Options (Sold separately)

Contents of Remote Control Set B

	Part No.	Part name	Pieces/Set	Note
1	04100609010	Remote control assembly	1	Remote control
2	04100515010	Remote control fixing bracket	1	Remote control wall-hanging bracket
3	31102381610	Bracket fixing screw	4	Flat head wood screw : nominal designation 3.8
4	-	Remote control installation instruction	1	
5	-	Remote control instruction manual	1	
6	03100677020	Power supply unit assembly	1	
7	31083401010	Power supply unit fixing screw	4	Truss tapping screw : nominal designation 4
8	11100000050	Round crimp-style terminal (M4)	2	Power supply unit power connection
9	11100000080	Round crimp-style terminal (M8)	2	
10	-	Power supply unit installation instruction	1	

Installation



Installation should be carried out by local dealer in your area or by a specialized installation engineer. Installing this product on your own may result in leakage, electric shock, or fire.

Contents





 Essential Safety Precautions	68
Moving the Product to the Installation Site	70
Installation	71
Specifications	81
External dimensions	82
Wiring diagram	83

Essential Safety Precautions

Usage Precautions (WARNINGS)

WARNINGS

Failure to observe the instructions contained in a WARNING may result in death or severe injury.



	<p>Be sure to install this product in accordance with the instructions given in this manual. Improper installation may lead to water leakage, electric shock, or fire.</p> <p>Installation should be carried out by local dealer in your area or by a specialized installation engineer. Improper installation may lead to water leakage, electric shock, or fire.</p> <p>Electrical work should be carried out in accordance with the instructions given in this manual. Use dedicated circuitry only. Improper workmanship or insufficient electrical capacity may result in electric shock, fire, or other hazard.</p> <p>Be sure to use the specified cable types. Fasten cables to terminals such that the connection area is isolated from external forces. Improper connection or poorly fastened cables may lead to electric shock or fire.</p> <p>Be sure to use hanging eyebolts correctly. Always use 4 hanging eyebolts. Be sure that the angle of each lifting cable relative to the horizontal surface of the product is at least 60 degrees. Improper hoisting may result in injury from dropped or overturned product.</p> <p>Be sure to perform the refrigerant leakage prevention. In case of installing the product in a machine room, it is necessary to take a countermeasure in order not to over the concentration limit even if the refrigerant leakage occurs. If the refrigerant leakage occurs and the concentration limit is over, it may cause the lack of oxygen.</p>
	<p>Do not modify this product. Improper modification of the internal wiring or piping may lead to electric shock or fire. Unauthorized modification will void the warranty.</p>
	<p>Do not change the settings of safety devices. Changing the safety settings may lead to product damage or fire.</p> <p>Do not install this product in areas where flammable gas leaks may occur. Presence of flammable gas around this product may result in fire.</p> <p>Do not operate in places that are very dusty or have corrosive atmospheres. Doing so may damage the product.</p> <p>When you need to install this product outdoors, avoid locations where the product may be exposed to direct sunlight, strong wind (with velocity of 8 m/s or greater) or a risk of being covered with snow. (Protection grade IPX4 equivalent [a rain-protection roof not required])</p>
	<p>Be sure to provide proper grounding. Do not connect ground lines to gas or water pipes, lightning rods, etc. Improper grounding may lead to electric shock.</p>

Essential Safety Precautions

Usage Precautions (CAUTIONS)

CAUTIONS

Failure to observe the instructions contained in a CAUTION may result in injury or physical damage.

	<p>Be sure that the installation site is sufficiently strong to bear the full weight of this product. The product must be installed so that it is level, and must be secured into place so that it cannot be accidentally overturned. Improper installation may lead to injury from water leakage or from overturning of product.</p> <p>Be sure that drain piping is correctly installed and in good working order. Water leaks caused by improper draining may result in property damage.</p> <p>Be sure that the pressure of supplied water does not exceed 0.50MPa. Excess pressure may lead to product damage and water leakage. Water leakage presents an electric shock hazard.</p> <p>When detaching the cabinet, wear gloves for protection. The cabinet edges of the cabinet and others may cause injuries.</p>
	<p>Do not install in locations that may become cold enough to cause water within the product to freeze. Internal freezing may result in pipe rupture, water leakage, and property damage.</p> <p>Do not sit on, lean on, or place objects on this product. Overturning of product may result in damage or injury.</p>

Moving the Product to the Installation Site

Initial Check / Moving the Product to the Installation Site

Initial Check

After unpacking the product, check the specifications Plate to make sure that you have received the system that you ordered.(see page7.) And check that there are parts in the table below about the accessory too.

Parts name	Remarke	Pieces / set
Y-shaped strainer	Filter mesh 40	1
Barrel nipple	1B (to mount Y-shaped strainer)	1

Upon receiving the product, check it carefully for signs of shipping-related damage (scratches, dents, etc.). If you notice a problem, please contact local dealer in your area.

Moving the Product to the Installation Site

The product is heavy. Exercise due care when moving it.

The base of the product includes forklift slots. If using a forklift, insert the forks so that they reach all the way to the opposite side of the product.

Model	Mass (empty water tank)
RKED9000A - V	435 kg

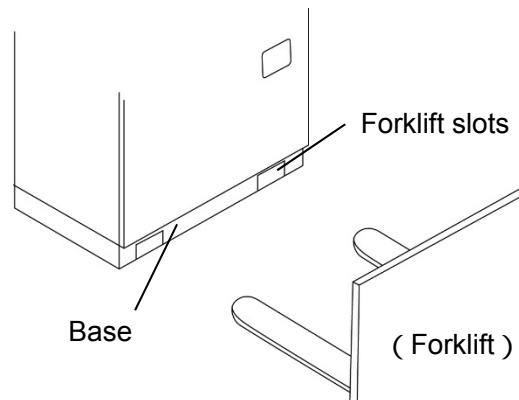

WARNING

If lifting by hanging eyebolts be sure to use all 4 of the hanging eyebolts. Also be sure that the angle of each lifting cable relative to the top of the product is at least 60 degrees. Improper hoisting may result in injury from dropped or overturned product.

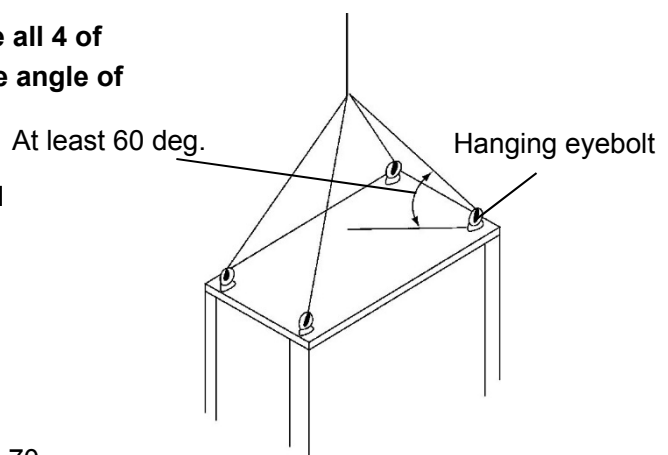

Installation

Installation Site

WARNING

Installation should be carried out by local dealer in your area or by a specialized installation engineer.

Installing this product on your own may result in water leakage, electric shock, or fire.

Installation Site

WARNING

Do not install in areas where flammable gas leaks may occur. Presence of flammable gas around this product may result in fire.

When you need to install this product outdoors, avoid locations where the product may be exposed to direct sunlight, strong wind (with velocity of 8 m/s or greater) or a risk of being covered with snow. Such conditions would not only degrade its designed performance but also make it prone to electric shocks, fires or product failure. (Protection grade IPX4 equivalent)

CAUTION

Install the product on a robust and even floor that can fully withstand its weight, and provide protection against falling with anchor bolts and other fixtures.

Improper installation may lead to injury from water leakage or overturning of product.

1. In order to help drafting exhaust heat as well as to ease maintenance and inspection operations, secure an adequate space for installation. Also note that the product might stop if it were enclosed as shown below due to re-absorbed exhaust heat and increased refrigerant pressure.

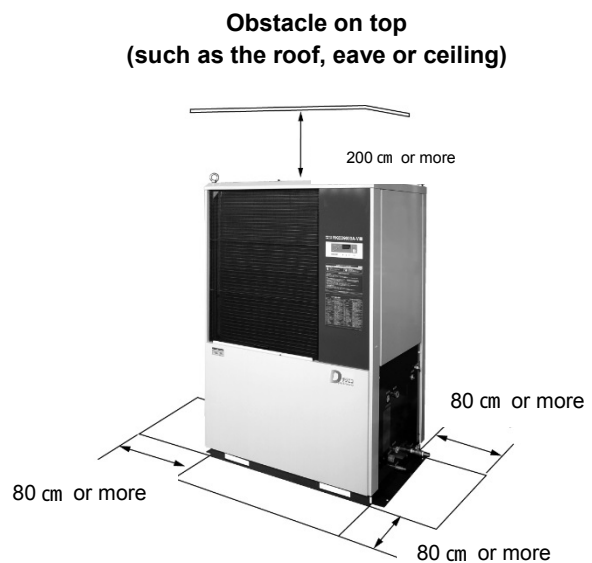
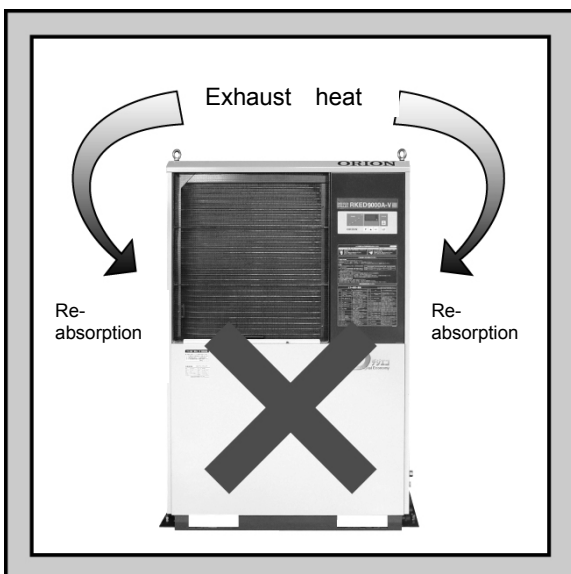

The upper clearance can be reduced to 100 cm above the product if there is no obstacle within 150 cm on the right, left and front sides.

Installation

Installation Site

2. If the product is exposed to wind with a velocity of 8 m/s or greater, windshield plates, storm walls or other wind-proof measures are required (see "Options" on page 67).
3. Install the product where it may not be exposed to direct sunlight or heat.
Exposure to direct sunlight or influence of heat may affect its cooling performance. Furthermore, its safety mechanism may be activated, disabling its operation.

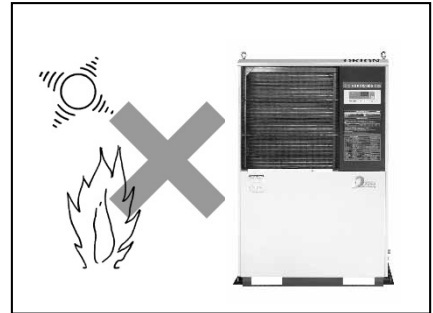

4. Use a product in a place where the ambient temperature is -5 to 43 . Operation at a temperature below -5 may cause a malfunction of the compressor.
Ambient temperatures above 43 may impede heat release from the condenser, resulting in safety-device activation and product shutdown. If you need to install the product in an area where ambient temperatures may exceed 43 , install the duct according to page 78 "Duct Design Procedure".

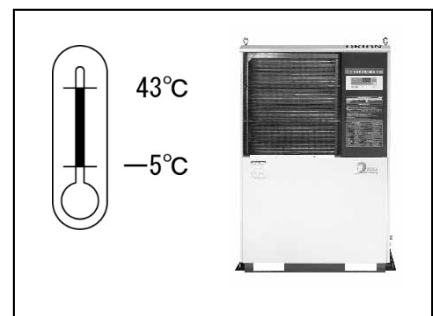

IMPORTANT

If installing ducts, be sure that these are sufficiently wide. Bad ducts may cause triggering of safety devices and shutdown of product.

5. Install where the dust/dirt level is low. Installation in a dusty environment would degrade the product's performance.

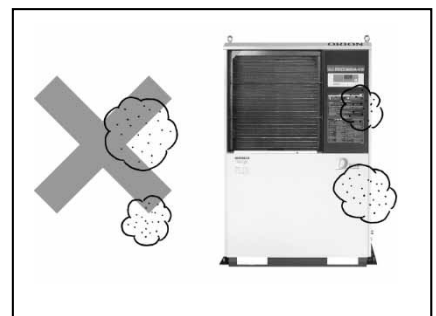

6. In a district where heavy snow covers are expected, the snow cover prevention mode (see page 27) may not be sufficient to secure its normal operation. Install a snow protection hood (see page 65).

Installation

Piping Installation

Piping Installation

! CAUTION

Be sure to install drain piping correctly. Water leaks caused by improper draining may cause property damage.

Be sure that the pressure of supplied water does not exceed 0.50MPa. Excess pressure may lead to equipment damage and water leakage. Water leakage presents an electric shock hazard.

When performing water piping, be careful to avoid the following points. Failure to do so can result in water leakage.

1. Overtightening the piping connected to the water supply port.
2. Having external forces on the water supply port.
3. Piping installation that does not absorb vibrations of water

hammer, etc. For exact piping port positions, see page 7, "Main Parts of the Unit".

Cold Water Piping

Piping Diameter

Pipe/Component	Piping Size
Cold Water inlet	Rc1
Cold Water outlet	Rc1
Water tank drain	Rc3/4
Overflow	Rp1
Outlet to drain pan	R1/2
Water supply port	Rp1/2

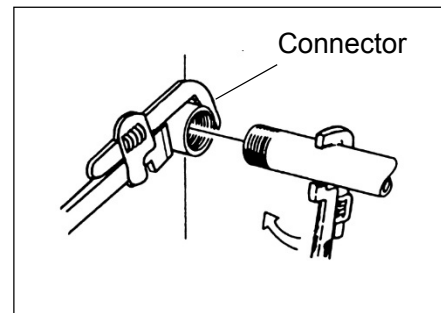

Pipe Connection Procedures

1. Be sure that you correctly distinguish between the Cold Water inlet and outlet.
2. Keep piping distances as short as feasible, and keep rises and bends to a minimum.
3. For tightening the over-flow piping use at two locations with a pipe wrench or a monkey wrench.
4. Install a valve (customer-supplied) at the Cold Water inlet/outlet.
5. Install the Y-shaped strainer included in the package at the Cold Water inlet.
6. Install the piping so that the connected piping weight and vibrations may not be directly applied onto this product.
If using long pipe, be sure to provide adequate support. Also avoid use of excess force at the pipe connection areas.
7. Pipes should be temperature-insulated.
(Provide a clearance between the product and the heat-retaining pipe for easy operations in removing the cabinet right middle plate and operating the bypass valve. Also, install so that the water level gauge is exposed to easy visibility.)
8. When providing an automatic water supply system for this product, be sure to install a valve at the water supply port. The supply pressure must be 0.50 MPa or less.
9. Please fix the water supply line with a supporting bracket.

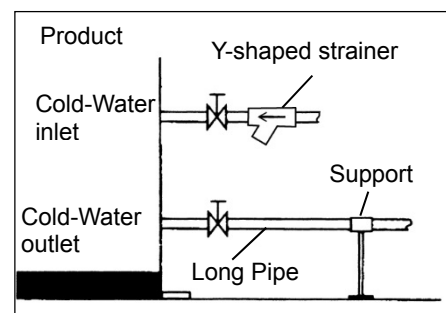

Installation

Piping Installation / Wiring Work

IMPORTANT

Misplacement of the Cold Water inlet or outlet on the piping will cause this product's performance to fail.

When the piping work is carried out, be sure not to enter the dirt or foreign substance into the water circuit.

Be sure to install the accompanying Y-shaped strainer at the Cold Water inlet. Intruded foreign matters would clog the evaporator, leading to failure.

We also recommend that you install piping for overflow and drainage as a precaution against water spill.

Be sure to install valves (customer-supplied) at the Cold Water inlet and outlet. Without these valves, you would need to drain the water circuit when cleaning the mesh section of the Y-shaped strainer.

Wiring Work



WARNING

Electrical work should be carried out in accordance with the instructions given in this manual, using dedicated circuitry only. Improper workmanship or insufficient electrical capacity may result in electric shock, fire, or other hazard.

Be sure to use specified cable types. Fasten cables to terminals such that the connection area is isolated from external forces. Improper connection or poorly fastened cables may lead to electric shock or fire.

Keep the power supply cord off the motor inside the product or the refrigerant piping. The heat from the piping might melt the cords, leading to electric leakage.



WARNING

Do not modify this product. Improper modification of internal wiring or piping may lead to electric shock or fire. Unauthorized modification will void the warranty.



WARNING

Do not change the settings of safety devices. Changing the safety settings may lead to product damage or fire.



WARNING

Be sure to provide proper grounding. Do not connect ground lines to gas or water pipes, lightning rods, etc. Improper grounding may lead to electric shock.



CAUTION

An appropriate leakage breaker must be installed. Failure to install a breaker may result in electric shock.

Installation

Wiring Work

IMPORTANT

This product must be connected to an industrial power supply. (Connection to secondary side of an inverter may result in product failure.)

Electrical Wiring

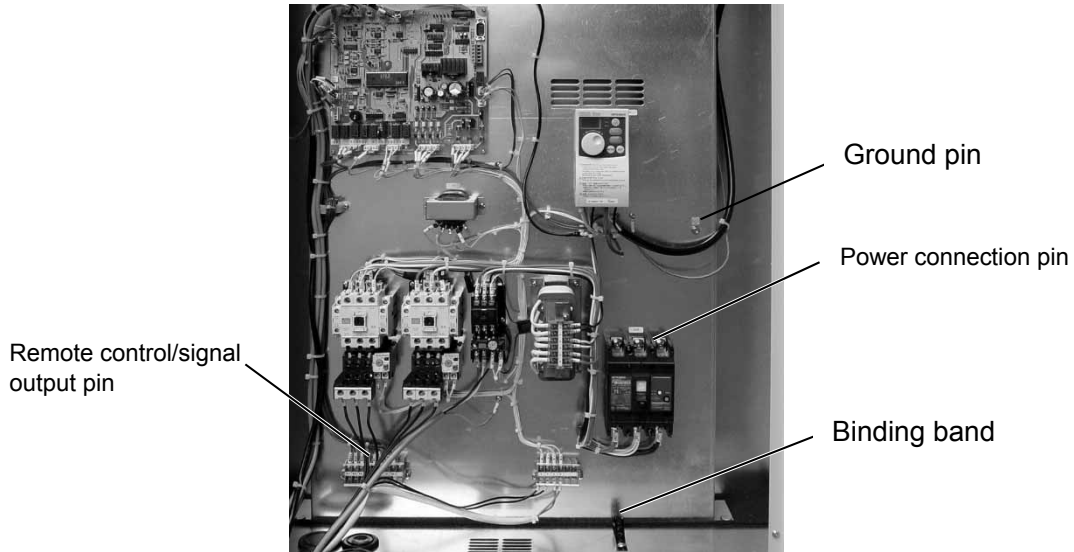

1. Select the power supply cord capacity in accordance with the maximum operation current as indicated in the table below. Attach the ground wire to the ground screw within the distributing board.

Please refer to screw size and terminal level width of the list shown below for the power supply and Signal terminal block.

			RKED9000A-V
Power (V · Hz)			3-phase 200 · 50/60, 3-phase 220 · 60
Maximum Operation Current (A)			58
Terminal	Screw size	Power	M8
		Signal	M3.5
	Terminal width (mm)	Power	19
		Signal	7.5

Installation

Wiring Work

2. The overload leakage breaker (provides both overload protection and current-leakage protection) is built-in inside of the distributing board.

Breaker Capacity (A)	75
Sensed current (mA)	30

3. Follow the instructions on page 49 to remove the cabinet front plate and the distributing board cover.
 4. Insert the power supply cord into the main body through the opening for power supply located at the bottom right of the body, and pull it into the distributing board.

(There are 2 openings for power supply; use one of them for the power supply cord. The other is for other purposes including installation of remote-control wiring.)

Connect the power supply cord wires to terminals L1, L2 and L3 on the distributing board's breaker.

Fix the power supply cord in place using the binding band.

5. Connect the ground.

Ground connection must be set up by a qualified electrician. The ground wire must be connected to the dedicated ground terminal. The wire diameter must be at least 2mm².

For the ground wiring, prepare terminals that match the screw sizes listed in the table below.

Ground wiring	M5
---------------	----

6. Note that the supplied power voltage should remain within 10% of the rated value while the product is operating. Also, use the power supply voltage with phase imbalance rate *of 3% or less.

$$*\text{Phase imbalance rate (\%)} = (\text{max. voltage (V)} - \text{min. voltage (V)}) / \text{avg. voltage of three phases (V)} \times 100$$

(according to IEC61800-3)

7. This product operates on 3-phase power. Phases must therefore be connected up correctly. If power phases are inverted, error code "E 10" will appear on the display when you start up the power supply. If this occurs, you should cut the power immediately. Never attempt to force operation by holding the electromagnetic contactor with the fingers or switch cord connections on the secondary side.

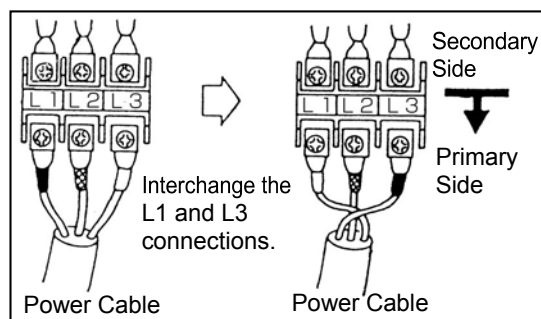

! WARNING

Keep the power supply cord off the motor inside the product or the refrigerant piping. The heat from the piping might melt the cords, leading to electric leakage. (Fix the power supply cord in place with the binding band inside the distributing board.)

When starting up the power supply, be sure to proceed in accordance with the instructions given in the "Operating Procedures" section of this manual.

Never operate the unit when the water circuit is empty. Always fill the water tank and confirm the water level before operating.

Never operate the product without water in the system. Be sure that there is sufficient water in the tank before starting up the product.

Installation

Wiring Work

Do not run withstand voltage tests or insulation resistance tests.
Failure to observe this may result in damage to the controller or the inverter's semi-conductors.
In addition, please contact local dealer in your area only when the test is absolutely necessary.

Setting Up to Use Remote Operation and External Signals

The product accepts input of a remote-control drive signal, and generates output of a drive signal and alarm signal. If you wish use these signals, please refer to the specifications below and connect up the wiring accordingly. Terminals should correspond to M3.5 screws.

1. Signal specifications are as follows.

Remote-Control Input	<ul style="list-style-type: none"> • Non-voltage contact input (alternating) • Maximum cable length : 20m • Input resistance : 1200 • Voltage when open : DC12V • Current when shorted : DC10mA
Signal Output	<ul style="list-style-type: none"> • Relay Output : "a" contact • AC250V/DC30V 3A (resistance load) • Minimum allowable current (reference value) DC5V 100mA

2. Terminal specifications are shown below.

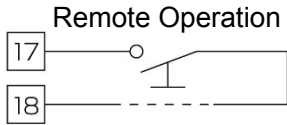
Remote-Control Terminals	<p>Remote Operation</p> 
Signal-Output Terminals	<ul style="list-style-type: none"> 13 RUNNING signal (Closed when product is running.) 15 Alarm signal (Closed to indicate ALARM condition.)

■ When Using Communications Functions

USB	<ul style="list-style-type: none"> • Connector: USB type B connector • Data cable max. length: 3m. May differ depending on specific operating conditions.
RS-422A (RS-485)	<ul style="list-style-type: none"> • Attach the stripped wires and use as is. • Data cable wire size: AWG16 to 24 • Data cable max. length: 100m. (from host to terminal end) May differ depending on specific operating conditions.

Please see page 30, "Communications Functions" for further details regarding communications functions.

■ In case of using the remote control (option)

Be sure to purchase the necessary option parts.(Refer to P72 "Options".)

Be sure to carry out the electrical work for the option parts in accordance with the attached installation Instruction.

Installation

Duct Design Procedure (for customer-supplied duct installations)

Duct Design Procedure (for customer-supplied duct installations)

When this product is installed in a small room or in a room with a low ceiling, exhaust heat may increase the ambient temperature to higher than 43 °C. In this case, a duct should be installed at the hot air discharge opening to guide exhaust heat out of the room or to any other area that may not affect the ambient temperature.

In designing the duct, keep the following considerations in mind.

1. Duct's cross-sectional area

(1) For a duct extending upward

Minimum cross-sectional area (m ²) [B x W]	0.519
Maximum length (m)	20

(2) Box-type joined or bending duct::

Prepare a duct with a cross-sectional area larger than the specified above.

Dimensions Lx and Ly must be **2m or less**. (See Fig. 1.)

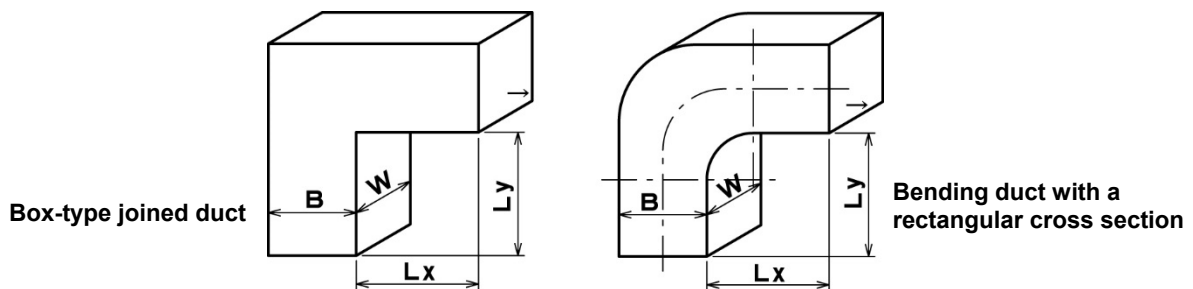

Fig. 1 Sample Shapes of Box-type Ducts

If dimensions Lx and Ly exceed 2m, provide a clearance of 20cm between the hot air discharge opening and also install a fan motor at the duct's vent.

Recommended Fan	Power supply : 50Hz	EJ-80FTC3 (Mitsubishi Electric Corp.)
	Power supply : 60Hz	EWG-60FTA(Mitsubishi Electric Corp.)
Minimum Airflow Requirement (m ³ /min)		186

In this case, however, do not allow dimensions Lx and Ly to exceed 5m. (See Fig. 2.)

The duct shape shown in the figure is simply an example. The air vent can be placed on any of the front, rear and side surfaces of this product, provided that the following important cautions be observed.

Fig. 2 Installation of Duct Exceeding 2m in Dimensions Lx and Ly

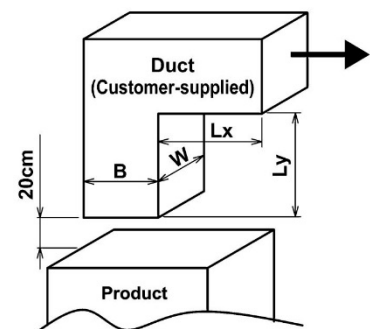

IMPORTANT

Keep the duct 2m or more away from the wall or any other obstacle in the air discharge direction. The airflow rate might decrease, leading to insufficient heat exhaustion, ultimately to stop the system via the safety mechanism.

Specifications

Model		RKED9000A-V		
Cooling Capacity	kW	*1	29.2/31.4	
External paint color			Ivory white(Munsell No.7.5Y7.5/0.5) Deep gray(Munsell No.N3.0)	
External dimensions (H x D x W)	mm		1800 x 850 x 1200	
Mass(Tank dryness)	kg		435	
Ambient temperature range	Deg.C		-5 to 43	
Cold water	4 Control accuracy		High accuracy operation mode: +/- 1.0 deg.C (during stable load operation: +/- 0.5 deg.C) Save energy operation mode: +/- 1.0 deg.C (during stable load operation: +/- 0.5 deg.C, at compressor on/off time: +/- 2.0 deg.C)	
	Service water temperature range	Deg.C	5 to 35	
	Use pressure	MPa	0.5 or below	
	The amount of the use minimum circulation	L/min	60/125(Lift:50m)	
	Water in and outlet connection dia.		Rc1	
Electrical ratings	Power source	V·Hz	*2 3 phase. 200 ± 10%(50/60) 220 ± 10%(60)	
	Power consumption	kW	*1 (14/17) (17)	
	Current	A	*1 (45/52) (52)	
	Power supply capacity	kVA	*3 (20)	
Operation control method			Compressor Load/Unload control	
Equipment Specifications	Compressor		Full-enclosed, and scrolling type (Digital)	
	Condenser		Fin and tube type, forced air cooling	
	Evaporator	Structure		Plate type
		Material		SUS316(with copper brazing)
	Discharge pump	Structure		Multistage centrifugal type
		Output	kW	2.2
	Fan motor output	W		750(Inverter drive)
	Water tank capacity	L		Approx. 95
	Water supply method			Ball tap(water supply pressure : 0.5 MPa or less)
	Refrigeration control method			Stepping motor operates directly type Electronic expansion valve
Refrigerant			R-407C	
Thermostat			Electric type (with alarm monitor)	
Communication	Standard		EIA Standard RS-422A/485,RS-232C conforming	
	maximum connected number		RS-422A/RS-485:32,RS232C:1	
Access Protective devices	Refrigerant compressor		Over-current relay/Discharge, suction temperature sensor/ Discharge, suction pressure sensor	
	Discharge pump		Over-current relay	
	Fan motor		Inverter electron thermal	
	Refrigeration cycle		High Pressure Switch	
	Water circuit		Float switch (for low limit alarm of water level)	
	Transformer		Thermal fuse	
Accessories	<ul style="list-style-type: none"> • Y-shape strainer 1B (filter mesh 40): 1 piece • Nipple 1B (to mount Y-shape strainer): 1 piece 			
	Option parts	<ul style="list-style-type: none"> • Option parts (Bought parts) 1.Caster(with stopper)/Caster(with adjuster) 2.Windproof plate 3.Snow proof hood. 4.Personal computer software for communication Drive and stop operations, Water temperature setting and display, Alarm display, Drive display, Drive data preservation is possible. 5. Remote control(Remote control set, Remote control cable ; Each optional) 6.Vibration isolated table 		
Remarks	<p>*1 Cold water temperature 20 deg.C, Room temperature 32 deg.C. Cooling capacity is at least 95% of listed figures.</p> <p>*2 It makes it within +/-3% the between the aspects of the voltage the unbalanced.</p> <p>*3 At maximum driving current within specifications</p> <p>*4 "While the load is being stabilized" means when a load state of within +/-10% of the current load continues. (However, this excludes the time when the capacity control solenoid valve opens and closes.) Select with the F15 parameter (initial setting: high accuracy operation mode)</p>			

Wiring diagram

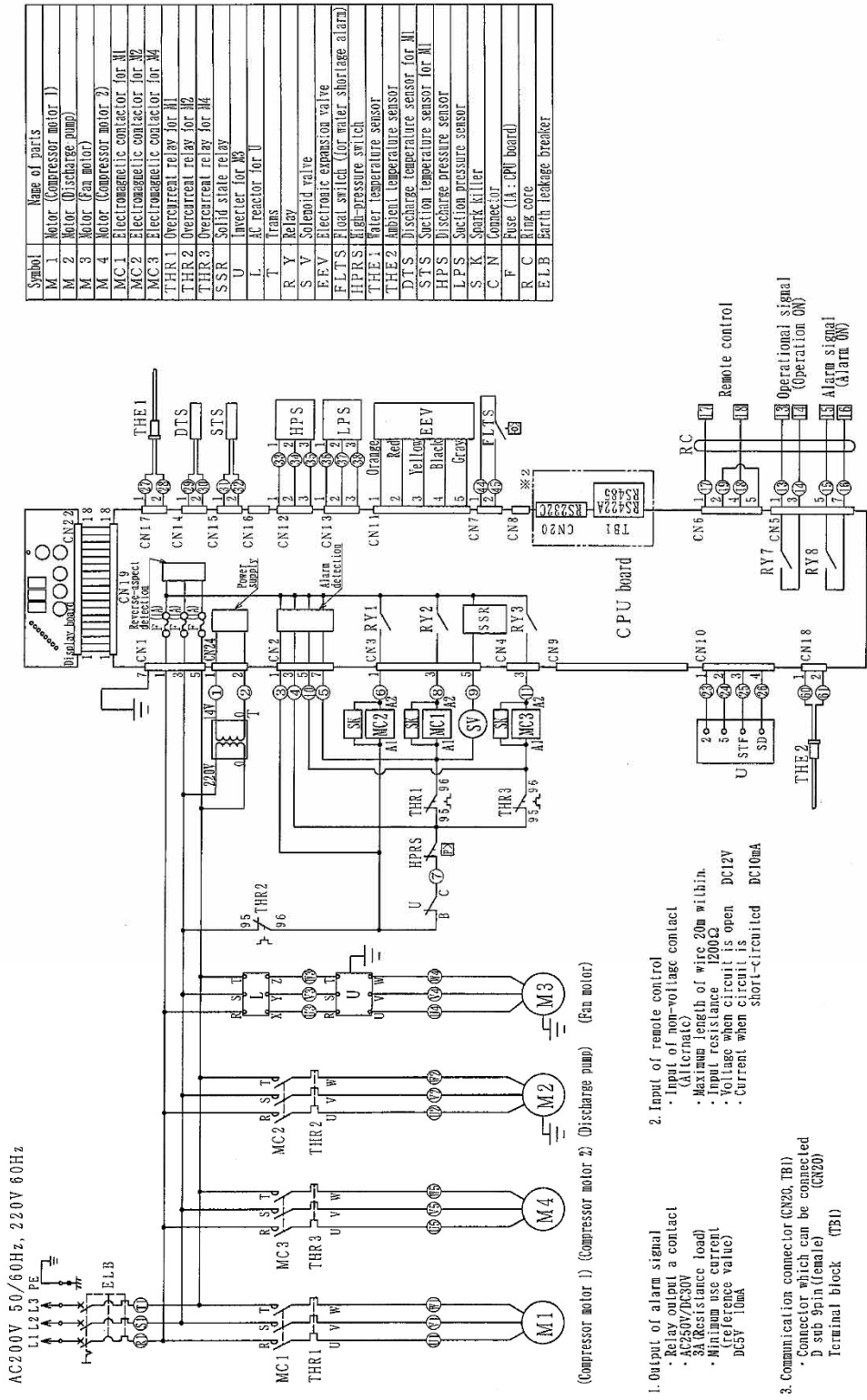

Symbol	Name of parts
M 1	Motor (Compressor motor 1)
M 2	Motor (Discharge pump)
M 3	Motor (Fan motor)
M 4	Motor (Compressor motor 2)
MC 1	Electromagnetic contactor for M1
MC 2	Electromagnetic contactor for M2
MC 3	Electromagnetic contactor for M4
THR 1	Overcurrent relay for M1
THR 2	Overcurrent relay for M2
THR 3	Overcurrent relay for M4
SSR	Solid state relay
U	Inverter for M3
L	A.C. reactor for U
T	Trans
R, Y	Relay
S, V	Solenoid valve
E, F, V	Electronic expansion valve
F, L, T, S	Flood switch (for water shortage alarm)
H, P, R, S	High-pressure switch
T, H, E, 1	Water temperature sensor
T, H, E, 2	Ambient temperature sensor
D, T, S	Discharge temperature sensor for M1
S, T, S	Suction temperature sensor for M1
H, P, S	Discharge pressure sensor
L, P, S	Suction pressure sensor
S, K	Spark killer
C, N	Connector
F	Fuse (A - CPU board)
R, C	Rear core
E, L, B	Earth leakage breaker

- Output of alarm signal
 - Relay output a contact
 - AC250V/DC50V
 - 3A Resistance load
 - Minimum use current (reference value) DC5V - 10mA
- Input of remote control (Alternatic)
 - Maximum length of wire 20m within.
 - Input resistance 1200Ω
 - Voltage when circuit is open DC12V
 - Current when circuit is short-circuited DC10mA
- Communication connector (CN20, TB1)
 - Connector which can be connected D sub 9pin (female) (CR20)
 - Terminal block (TB1)

Check List

No	Part Names	Date	Running Hour (x 100 hours)	Note
1				
2				
3				
4				
5				
6				
7				
8				
9				
10				
11				
12				
13				
14				
15				
16				
17				
18				
19				
20				

MEMO

Product Warranty

This product shall be warranted as follows. For warranty repairs, please contact the dealer where the product was sold after confirming the product model and serial number.

1. Warranty Period

- (1) Refrigerant circuits : Two years from the date of purchase, or 10,000 operating hours, whichever comes first.
- (2) Others : One year

2. What Is Covered by this Warranty

- (1) If breakdown occurs within the above warranty period and the cause of the breakdown lies with ORION, then the damaged part(s) will be replaced or repaired by ORION free of charge. Note that depending on the country/region where the product is being used, repairs may take more time or be impossible. Please consult with your dealer in advance regarding service and repair options for products to be operated outside of Japan.
- (2) In principal, the owner of the product will confirm diagnosis of the breakdown according to the operating manual. However, there might be cases where this work may be carried out instead by a member of ORION's service network. In such cases, there will be no charge where the cause of the breakdown lies with ORION.
- (3) Note that even during the warranty period, there will be costs incurred by the user (outside the warranty) in the following cases:
 - Breakdown resulting from operating under unsuitable operating conditions, environment, handling, use, or method of operation outside those written in the specifications or operating manual of the product, or as a result of carelessness or negligence on the part of the user.
 - Breakdown resulting from non-ORION equipment (user's own equipment or software design, etc.).
 - Breakdown resulting from repairs or modifications conducted by non-ORION designated contractors.
 - Breakdown which could be recognized as being avoidable in cases where an ORION product is used in conjunction with the user's equipment where the user's equipment is legally regulated to have a safety device whereby inclusion of the safety device could have averted the breakdown, or in cases where the addition of function, structure, etc., could have, according to common knowledge of the industry, averted the breakdown.
 - Any breakdown which is recognized as being avoidable had normal fixed term inspections, and/or normal maintenance and replacement of consumables, been performed as indicated in the operating manual, etc.
 - Replacement of consumables (parts to be replaced at fixed terms or based on inspection).
 - Breakdown due to external factors beyond human control such as fire etc., or breakdown resulting from natural disaster such as earthquake, lightning, storm and flood damage, etc.
 - Breakdown due to reasons unforeseeable due to the technological standard at the time the product was shipped from ORION.
 - Any breakdown resulting from corrosion caused by operating the product in an atmosphere that contains corrosive gases, organic solvents, chemical solutions, etc., or in an environment where such substances could come into contact with the product.
- (4) In cases where a separate contract, etc. has been established, that contract will take priority.

3. Warranty Obligation Exclusions

Regardless of the warranty period, compensation for any of the following will not fall under the obligations of this warranty: any hindrance or accident compensation resulting from reasons not under ORION's obligations; any lost opportunities, lost profit, secondary losses, damages to non-ORION equipment incurred by users resulting from the breakdown of ORION products; and any replacement work, readjustment of on-site machinery and equipment, and operating work by users.

4. Product Use Limitations

- (1) When using ORION products in connection with important facilities, be sure to establish backup and/or failsafe measures so that even in the event of breakdown of such products, such breakdown will not lead to serious accidents or losses.
- (2) ORION products are designed and produced as general purpose equipment to be used in general industrial applications. Therefore, this warranty will not apply when used in the following applications: However, in cases where the customer/user takes full responsibility and confirms the performance of the product in advance, and takes necessary safety precautions, please consult with ORION and we will consider if use of the product in the desired application is appropriate.
 - Atomic energy, aviation, aerospace, railway works, shipping, vehicles (cars and trucks), medical applications, transportation applications, and/or any applications where it might have a great effect on human life or property.
 - Electricity, gas, or water supply systems, etc. where high levels of reliability and safety are demanded.



ORION MACHINERY CO., LTD.

ORION MACHINERY CO., LTD.

Head Office and Factory: No.246 Kotaka, Suzaka City, Nagano Pref. 382-8502, Japan
Tel +81-(26)-245-1230 FAX +81-(26)-245-5424

 No.2167 20160728 C. T.G. J.F.